

INVERTER POOL PUMP

INSTALLATION AND OPERATION MANUAL

EN-INSTALLATION AND OPERATION MANUAL.....	2
FR- MANUEL D'INSTALLATION ET D'UTILISATION.....	31
ES- MANUAL DE INSTALACIÓN Y OPERACIÓN.....	62
PT- MANUAL DE INSTALAÇÃO E OPERAÇÃO.....	93
DE- INSTALLATIONS- UND BEDIENUNGSANLEITUNG.....	124
NL- INSTALLATIE- EN BEDIENINGSHANDLEIDING.....	155
IT- MANUALE DI INSTALLAZIONE E FUNZIONAMENTO.....	186
HR- UPUTE ZA MONTAŽU I RAD.....	217



CONTENTS

1. ⚠ IMPORTANT SAFETY INSTRUCTIONS.....	3
2. TECHNICAL SPECIFICATIONS.....	4
3. OVERALL DIMENSION (mm).....	4
4. INSTALLATION.....	5
5. SETTING AND OPERATION.....	7
6. WIFI OPERATION (OPTIONAL ITEM)	16
7. EXTERNAL CONTROL.....	25
8. PROTECTION AND FAILURE	27
9. MAINTENANCE	30
10. WARRANTY & EXCLUSIONS.....	30
11. DISPOSAL.....	30

THANK YOU FOR PURCHASING OUR INVERTER POOL PUMPS.

THIS MANUAL CONTAINS IMPORTANT INFORMATION THAT WILL HELP YOU IN OPERATING AND MAINTAINING THIS PRODUCT.

PLEASE READ THE MANUAL CAREFULLY BEFORE INSTALLATION & OPERATION AND RETAIN IT FOR FUTURE REFERENCE.

1. IMPORTANT SAFETY INSTRUCTIONS

When installing and using this electrical equipment, basic safety precautions should always be followed, including the following:

- 1) READ AND FOLLOW ALL INSTRUCTIONS
- 2) WARNING – To reduce the risk of injury, do not permit children to use this product unless they are closely supervised at all times.
- 3) WARNING – Risk of Electric Shock. Connect only to a branch circuit protected by a residual current device (RCD) with a rated residual operating current that does not exceed 30 mA. Contact a qualified electrician if you cannot verify that the circuit is protected by a residual current device RCD.
- 4) TO PREVENT THE ELECTRICAL SHOCK RISK, please connect the ground wire on the motor (green/yellow) to the grounding system.
- 5) WARNING – To reduce the risk of electric shock, replace the damaged cord immediately.
- 6) Do not install within an outer enclosure or beneath the skirt of a hot tub or spa.
- 7) A disconnecter must be fitted to the fixed electrical installation in accordance to the installation regulations.
- 8) For Use with Swimming Pools, Hot Tubs, and Spas.
- 9) CAUTION: To reduce the risk of electric shock, install at least 1.8m from the inside walls of a pool. Do not use an extension cord.
- 10) CAUTION: To ensure continued protection against shock hazard, use only identical replacement parts when servicing.
- 11) This pump is for use with permanently installed in-ground or above-ground swimming pools and may also be used with hot tubs and spas with a water temperature under 50°C. Due to the fixed installation method, this pump is not suggested to be used on above-ground pools that can be readily disassembled for storage.
- 12) The pump is not submersible.
- 13) Never open the inside of the drive motor enclosure.
- 14) SAVE THESE INSTRUCTIONS

WARNING:

- Fill the pump with water before starting. Do not run the pump dry. In case of dry run, mechanical seal will be damaged and the pump will start leaking.
- Before servicing the pump, switch power OFF to the pump by disconnecting the main circuit to the pump and release all pressure from pump and piping system.
- Never tighten or loosen screws while the pump is operating.
- Ensure that the inlet and outlet of the pump are unblocked with foreign matter.

2. TECHNICAL SPECIFICATIONS

Model	Advised Pool Volume (m ³)	P1	Voltage (V/Hz)	Qmax (m ³ /h)	Hmax (m)	Circulation (m ³ /h)	
		KW				At 10m	At 8m
DCP12-IG	40-70	1.2	220-240/ 50/60	28.0	20.0	23.0	26.0

3. OVERALL DIMENSION (mm)

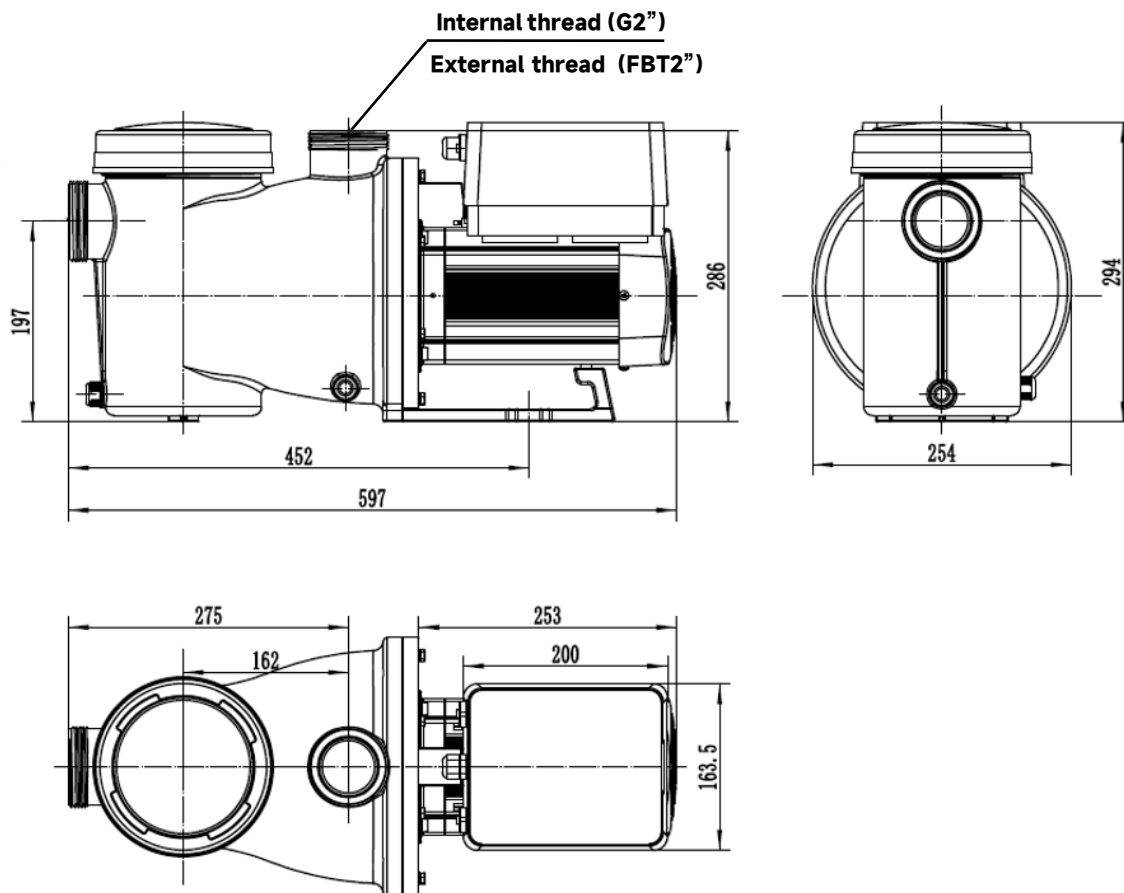

Figure 1 - Pump Dimensions

4. INSTALLATION

4.1. Pump Location

- 1) Install the pump as close to the pool as possible, to reduce friction loss and improve efficiency, use short, direct suction and return piping.
- 2) To avoid direct sunshine, heat or rain, it is recommended to place the pump indoors or in the shade.
- 3) DO NOT install the pump in a damp or non-ventilated location. Keep pump and motor at least 150mm away from obstacles, pump motors require free circulation of air for cooling.
- 4) The pump should be installed horizontally and fixed in the hole on the support with screws to prevent unnecessary noise and vibration.

4.2. Plumbing and Valves

- 1) The pump inlet/outlet union size: optional with 48.3/50/60.3/63mm..
- 2) For optimization of the pool plumbing, a larger pipe size should be used. It is recommended to use a pipe with size of 63mm.
- 3) When installing the inlet and outlet fittings (joints) with the plumbing, use the special sealant for PVC material.
- 4) The dimension of suction line should be the same or larger than the inlet line diameter, to avoid pump sucking air, which will affect the pump's efficiency.
- 5) To reduce friction loss and improve efficiency, plumbing on the suction and return side should be short and direct.
- 6) Flooded suction systems should have valves installed in both the pump suction and return line, which is convenient for routine maintenance. A valve, elbow, or tee installed on the suction line should be no closer to the front of the pump than seven times the suction line diameter.
- 7) Use a check valve in the return line where there is a significant height between the return line and the outlet of the pump, to prevent the pump from the impact of medium recirculation and pump-stopping water hammer.

4.3. Fittings

- 1) Elbows should be no closer than 350mm to the inlet. Do not install 90° elbows directly into the pump inlet/outlet.
- 2) Joints must be tight.

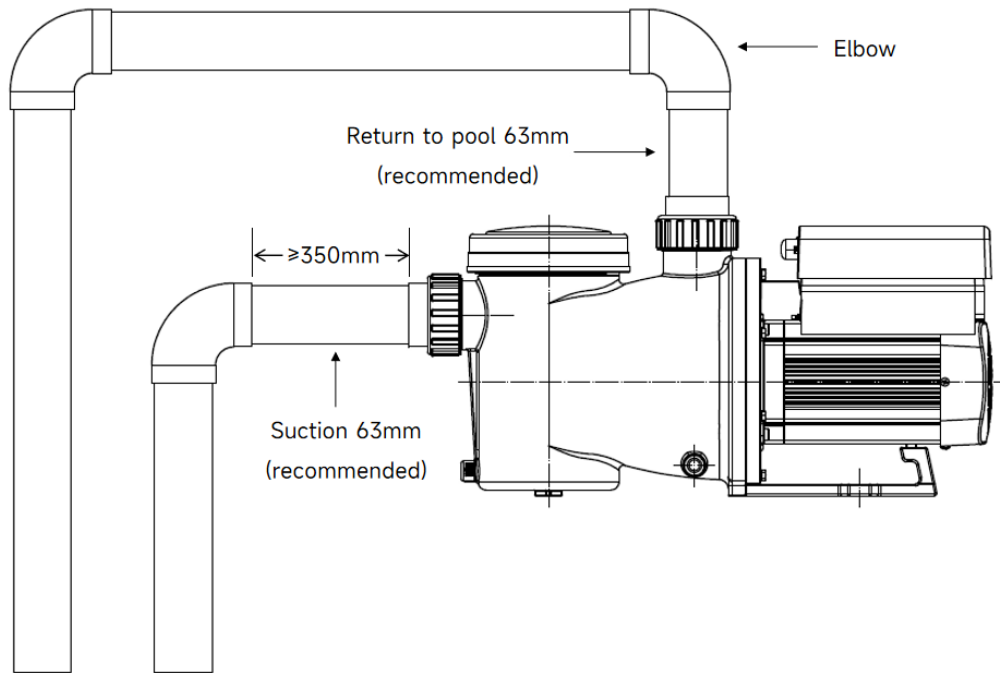

Figure 2 - Plumbing and Fittings installations

* The pump inlet/outlet union size: optional with 48.3/50/60.3/63mm

- 3) Use the UNION KIT supplied by the pump manufacturer (Refer to Figure 3). Do not use other fittings to connect the pump inlet/outlet, in case the fittings are not match and damage the pump body.

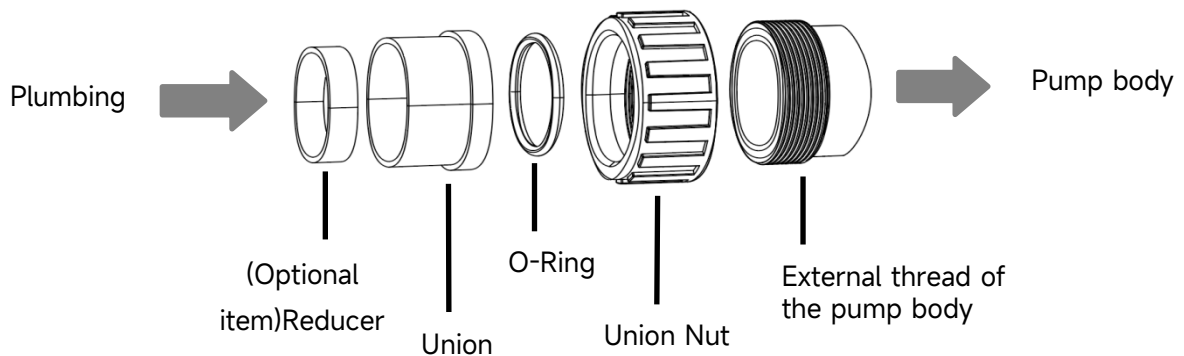

Figure 3 - Union Kit

4.4. Check before initial startup







- 1) Check whether pump shaft rotates freely;
- 2) Check whether power supply voltage and frequency conform to the nameplate;
- 3) Facing the fan blade, the direction of motor rotation should be clockwise;
- 4) It is forbidden to run the pump without water.

4.5. Application conditions

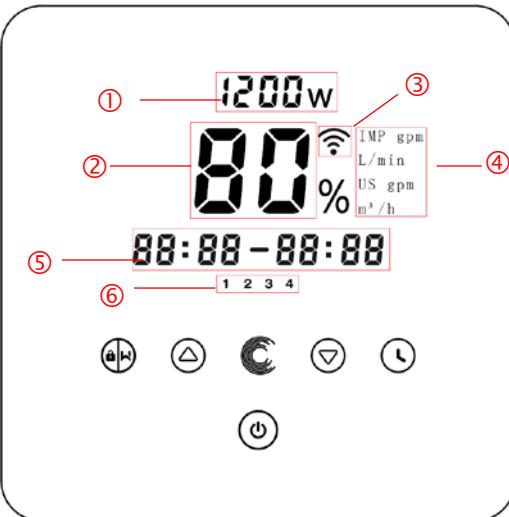
Ambient temperature	Indoor installation, temperature range: -10-42°C
Maximum water temperature	50°C
Salt water available	Salt concentration up to 3.5%, i.e 35g/l
Humidity	≤90% RH, (20°C±2°C)
Installation	The pump can be installed max. 2m above water level
Protection	Class F, IP55

5. SETTING AND OPERATION



5.1. Display on control panel

	① Power consumption
	② Running capacity / Flow rate
	③ WIFI indicator (optional item)
	④ Unit of flow
	⑤ Timer period
	⑥ Timer 1/2/3/4
	 Backwash/unlock
	 Up/down: to change the value of setting
	 Switch between Manual Inverter Mode and Auto Inverter Mode. Manual Inverter Mode: The running capacity will be set manually between 30%-120%. Auto Inverter Mode: The running capacity will be automatically adjusted between 30%-120% according to the preset flow rate. The default mode is Manual Inverter mode.
	 Timer setting
 On/off	

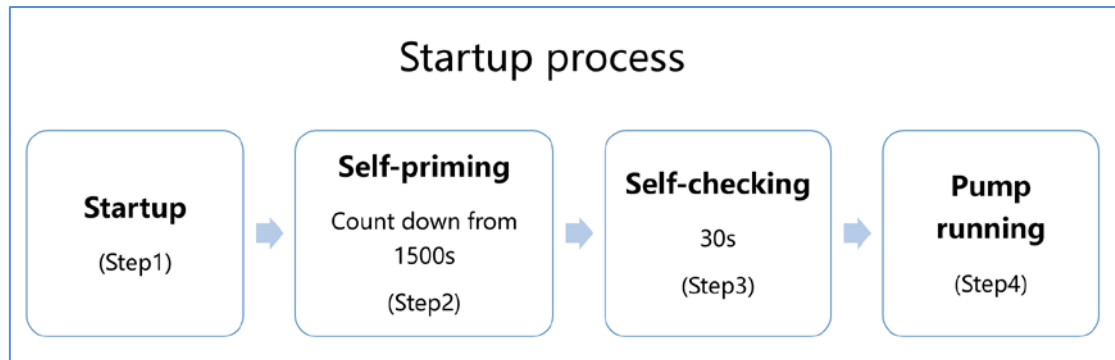
5.2. Startup process overview



① Step 1: Startup

- Press and hold  for more than 3 seconds to unlock the screen.
- Press  to startup the pump.

② Step 2: Self-priming

- The pump will start counting down from 1500s; When the system detects the pump is full of water, it will stop counting down and exit priming automatically.
- Users can enter the parameter setting to disable the default self-priming function (see 5.11).

③ Step 3: Self-checking



- The pump will recheck for 30s again to make sure the self-priming (Step2) is completed.

④ Step 4: Pump running

- The pump will run at 80% of the running capacity at the initial startup after the self-priming.

5.3. Startup

When the power is switched on, the screen will fully light up for 3 seconds, the device code will be displayed, and then it will enter the normal working state. When the screen is locked, only the button  will light up;

Press and hold  for more than 3 seconds to unlock the screen. The screen will automatically lock up when there is no operation for more than 1 minute and the brightness of the screen will be reduced to 1/3 of the normal display. Short press  to wake up the screen and observe the relevant operating parameters.

5.4. Self-priming

Each time the pump is started, it will start self-priming.

When the pump performs self-priming, it will count down start from 1500s and stop count down automatically when the system detects the pump is full of water, then the system will recheck for 30s again to make sure the self-priming is completed.



Users can cancel self-priming manually by pressing  for more than 3 seconds. The pump will enter the default Manual Inverter mode at the initial startup.

Remark:

The pump is delivered with self-priming enabled. Each time the pump restarts, it will perform self-priming automatically. Users can enter the parameter setting to disable the default self-priming function (see 5.11)

5.5. Backwash











Users can start the backwash or fast re-circulation in any running state by pressing .

	Default	Setting range
Time	180s	Press  or  to adjust from 0 to 1500s with 30 seconds for each step
Running capacity	100%	60-100%, enter the parameter setting (see 5.11)

Exit backwash:

When backwash mode is on, users can hold  for 3 seconds to cancel it, the pump will return to the previous state before backwash. If a speed limit is set by the users, the running capacity of the backwash will not exceed the set speed limit. (see 5.10)

5.6. Manual Inverter Mode

1		Hold  for more than 3 seconds to unlock the screen.
2		Press  to start. The pump will run at 80% of the running capacity at the initial startup after the self-priming.
3	 	Press  or  to set the running capacity between 30%-120%, each step by 5%.
4		Press  again to switch to Auto Inverter mode.













Note:

- 1) When the pipeline pressure is high, to maintain an adequate flow rate, users can set the running capacity to 105%-120%. The pump will run at a higher speed to against the high pipeline pressure.
- 2) At the range of 105%~120% running capacity, the pump will automatically adjust the speed when it reaches the maximum power.

For example, when the users adjust the speed to 110%, if the pump power has reached to the maximum value at this speed, at this time, even if the users continue to increase the pump speed to 120%, the pump will maintain the speed at the maximum power, i.e. 110%. And the display speed will drop from 120% to 110%.

5.7. Auto Inverter Mode

Under Auto Inverter Mode, the pump can automatically detect the system pressure and adjust the speed of motor to reach the set flow.

1		Unlock the screen, press  to switch from the Manual Inverter mode to Auto Inverter mode.
2	 	The flow rate could be adjusted, by pressing  or  with 1m ³ /h for each step.
3	 	The unit of flow rate could be changed to L/min, IMP gpm or US gpm, by pressing both   for 3 seconds.
4		Press  to switch to Manual Inverter mode.

The default adjustable flow range for InverK is as below:

Model	Adjustable flow rate range*
DCP12-IG	8-25 m ³ /h

***Note:**











In Auto Inverter Mode, the maximum adjustable flow rate is based on around 8m head.

If users set the flow at maximum adjustable flow rate and the pipeline pressure is higher than 8m, in this situation the pump will automatically increase the running speed and input power to against with the high pressure and maintain the maximum flow rate which the users set.

When the motor speed and input power increase to the maximum level but it's not enough to against with the huge pipeline pressure, the display flow on the pump controller will drop from the set flow to the actual achievable flow.

5.8. Timer mode

The pump's on/off and running capacity could be commanded by a timer, which could be programmed daily as needed.





1	Enter timer setting by pressing 
2	Press  or  to set the local time
3	Press  to confirm and move to time-1 setting
4	Press  or  to choose the desired running periods, running capacity or flow rate (when % icon is flashing, users can change to set the flow rate by pressing )
5	 Repeat above steps to set the other 3 timers
6	 Hold 3 seconds to save setting and activate timer mode
7	 or  Check 4 timers to make sure there is no invalid setting

Note:

1) If the set time period contains the current time, the pump will start running according to the set running capacity or flow rate, the current timer indicator

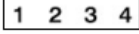
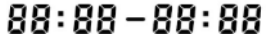

1	2	3	4
---	---	---	---



 (1 or 2 or 3 or 4) will light up, and the area **88:88-88:88** will display the corresponding time period.

- 2) If the set time period does not contain the current time, the timer number  (1 or 2 or 3 or 4) that is about to start running will be displayed and flash, and the area  will display the corresponding time period.
- 3) During timer setting, if you want to return to the previous setting, hold both   for 3 seconds. If you don't need to set all 4 timers, you can hold  for 3 seconds, the system will automatically save the current set value and activate the timer mode.
- 4) The timer settings of the pump have been limited, users will not set the overlapping timers.
- 5) After the timer is set and then users turn off the pump, when users turn on the pump again, it will continue to return to the timer mode.
- 6) Users can cancel the timer mode by pressing .

5.9. Skimmer Mode

The skimmer mode enables the pump to skim the water surface, prevents the debris from accumulating, and provides users with a cleaner pool.

Hold  and  to enter the preset interface of the skimmer mode. When first switching to this mode, preset 1 will be activated.

Users can press  or  to view the 4 presets, the details of each preset are as below, the selected preset will be activated after 5s without operation.

Preset	Skimmer cycle	Skimmer duration	Skimmer speed	Time period	Remark
1	1h	3 mins	100%	7:00 – 21:00	Editable in parameter setting
2	1h	10 mins	100%	7:00 – 21:00	Not editable
3	3h	3 mins	80%	7:00 – 21:00	Not editable
4	Turn off the skimmer mode				Not editable

Table 1 - Presets of skimmer mode

At the skimmer duration, the controller will display the parameter of the preset, users can hold  for 3 seconds to cancel the skimmer duration each time. When the skimmer duration ends, the pump will return to the normal state for the users to operate.

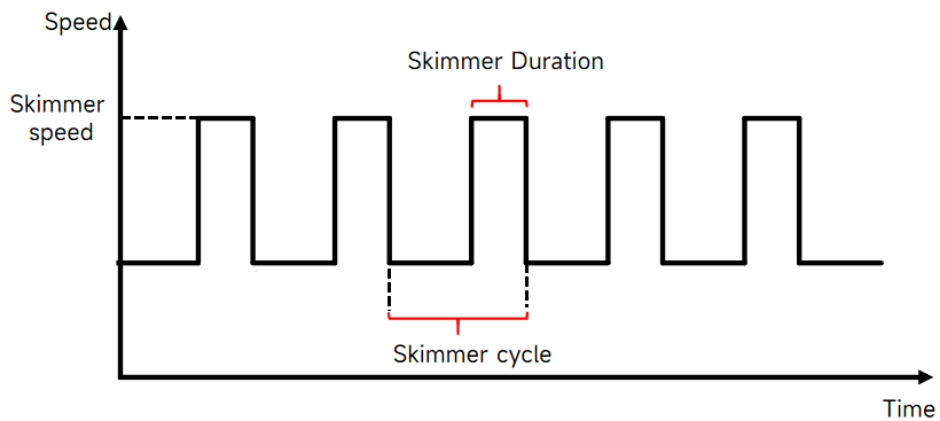
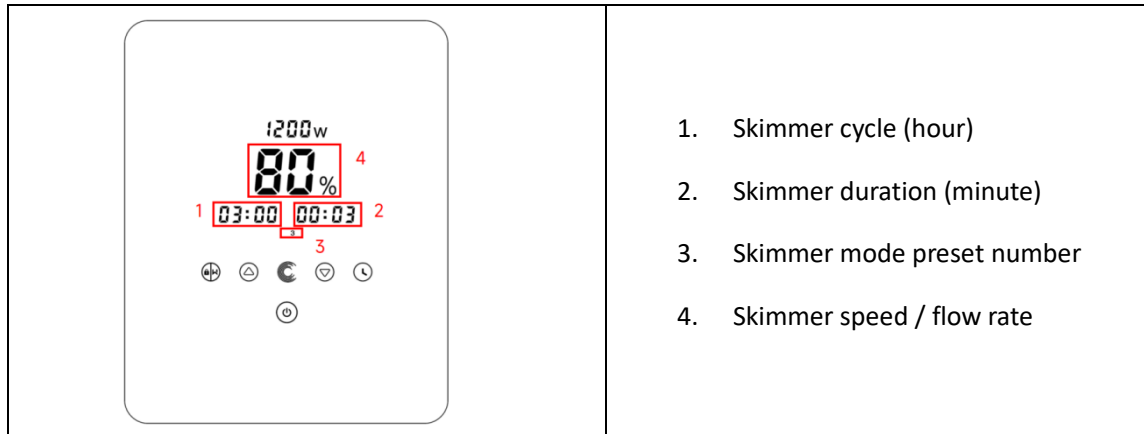

Figure 4 - Skimmer cycle

5.10. Speed / Flow Limit

Users can set the speed/flow limit of the pump to meet the flow requirement of other equipment such as sand filters.









Speed/flow limit of the pump can be set in the parameter setting. (see 5.11)



100% means no speed limit and the running capacity can be set from 30% - 120% under normal operation.



Model	Speed / Flow limit	
	Maximum Running Speed	Maximum Flow Rate
DCP12-IG	60%-100%	15~25 m ³ /h

To ensure the performance, the self-priming process at each start will not be limited by the speed/flow limit function.





5.11.Parameter Setting

Restore factory setting	Switch off the pump, then hold both   for 3 seconds
Check the software version	Switch off the pump, then hold both   for 3 seconds
Enter parameter setting as below	Switch off the pump, then hold both   for 3 seconds; Press  to select the parameter address and press  or  to adjust the parameter setting.

Parameter Address	Description	Default Setting	Setting Range
1	Di2 (Digital input 2)	Speed: 100%	Speed: 30-120%, by 5% increments; Flow: by 1 m ³ /h increments; DCP12-IG: 8~25 m ³ /h Note: Press  to switch to flow rate setting.
2	Di3 (Digital input 3)	Speed: 80%	
3	Di4 (Digital input 4)	Speed: 40%	
4	Backwash	Speed: 100%	Speed: 60-100%, by 5% increments; Flow: by 1 m ³ /h increments; DCP12-IG: 8-25 m ³ /h Note: Press  to switch to flow rate setting.
5	Control mode of Analog Input	0	0: Current control 1: Voltage control
6	Enable or disable the self-priming at each start	25	25: enables 0: disables

7	Reserved	0	Not editable
8	System time	00:00	00:00 - 23:59
9	Preset 1 of the skimmer mode	Skimmer cycle : 01:00 Skimmer duration : 00:03 Skimmer speed : 100%	*Skimmer cycle: 1-24h, 1h for each step; *Skimmer duration: 1-30min, 1min for each step; *Skimmer speed: 30%-100%, by 5% increments; *Skimmer flow: by 1 m ³ /h increments increments; DCP12-IG: 8-25 m ³ /h Note: Press  to switch to flow rate setting.
10	Time period of the preset 1 of the skimmer mode	7:00-21:00	Start time: 00:00-24:00 End time: 00:00-24:00
11	Speed limit	Speed: 100%	Speed: 60%-100%, by 5% increments; (100% means no speed limit) Flow: by 1 m ³ /h increments; DCP12-IG: 15-25 m ³ /h Note: Press  to switch to flow rate setting.
12	RS485 address	170(0xAA)	160-190 (0xA0-0xBF), each step by 1.
13	Reserved	0	Not editable

For example: How to Enable / Disable Self-Priming Function?

- 1) **Enter parameter setting:** Switch off the pump, then hold both   for 3 seconds;
- 2) **Select parameter address:** Press  to select address 6;
- 3) **Enable or disable the self-priming function:** Adjust by pressing  or , 25= Enables, 0=Disables.

6. WIFI OPERATION (OPTIONAL ITEM)

- 1 Download iGarden APP
- 2 Account Registration



Android



iOS

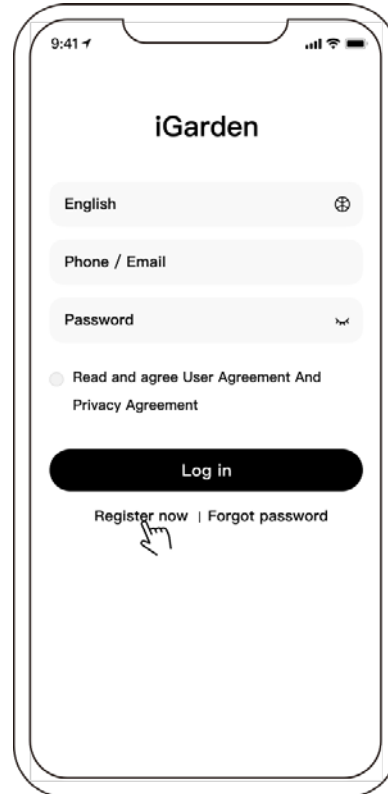

Phone / Email Registration

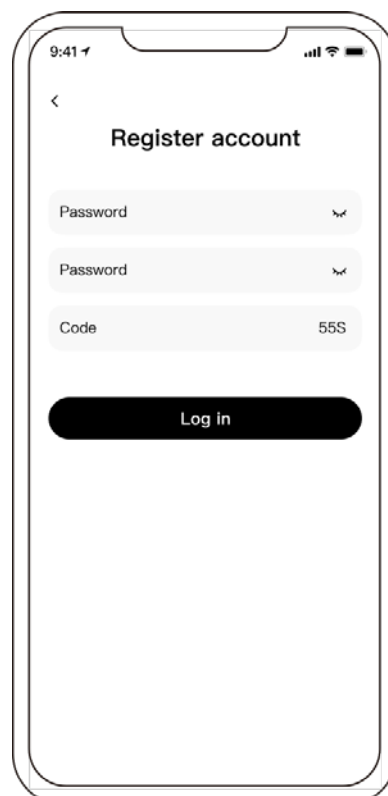
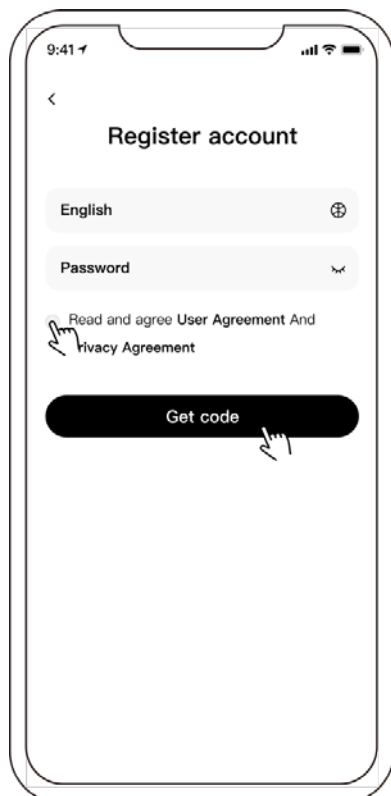



3 App Pairing

Please make sure your pump is turned on before you start.

(Network condition: 2.4GHz; 2.4Ghz and 5GHz combine into one SSID; but no separate 5GHz network)

1) Please confirm that your phone is connected to Wifi and the Bluetooth of your phone is ON.

2) Press  for 3 seconds to unlock the screen. After switching on the pump, press  for 5 seconds until hearing “Beep” and then release.  will flash.

3) Click “Add Device”, and then follow the instructions to pair device.

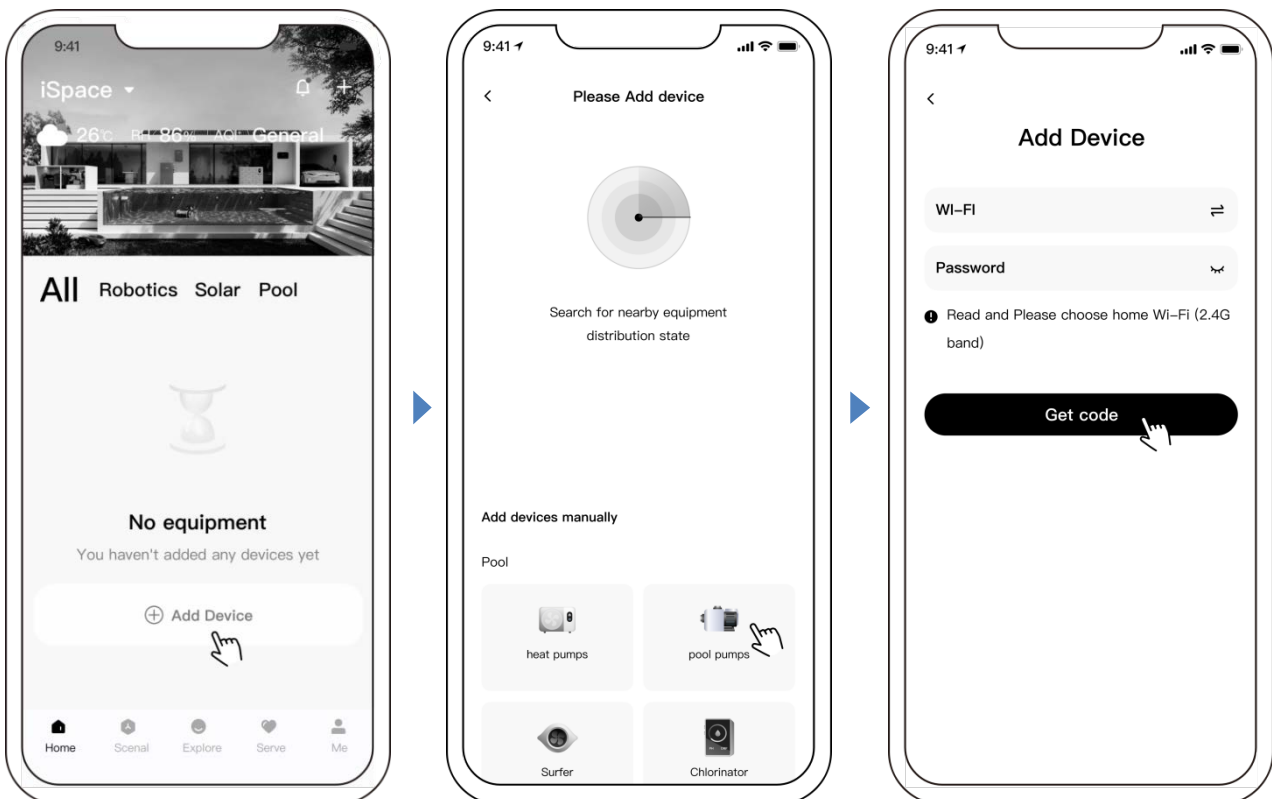

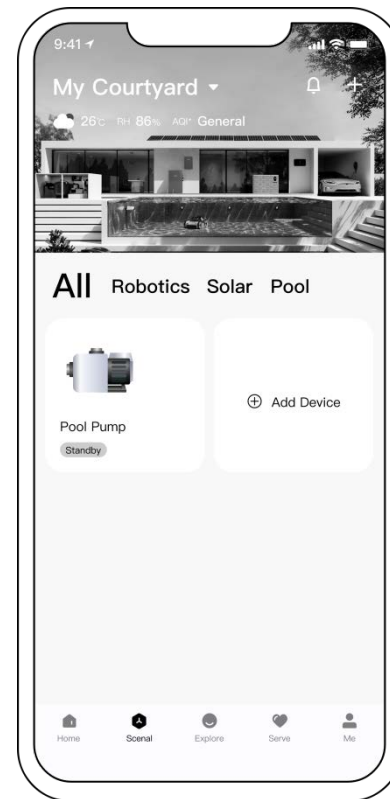
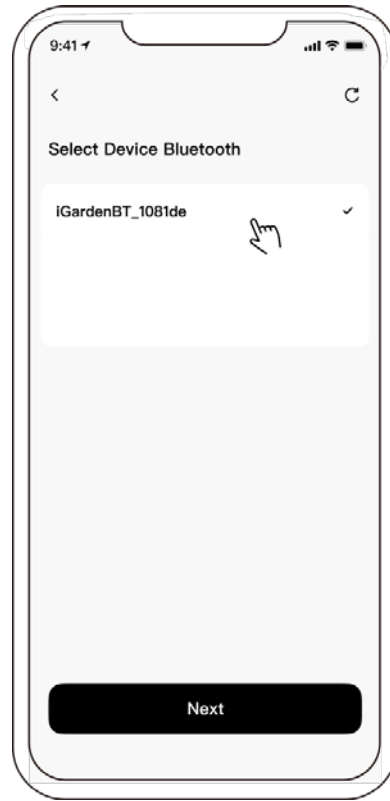
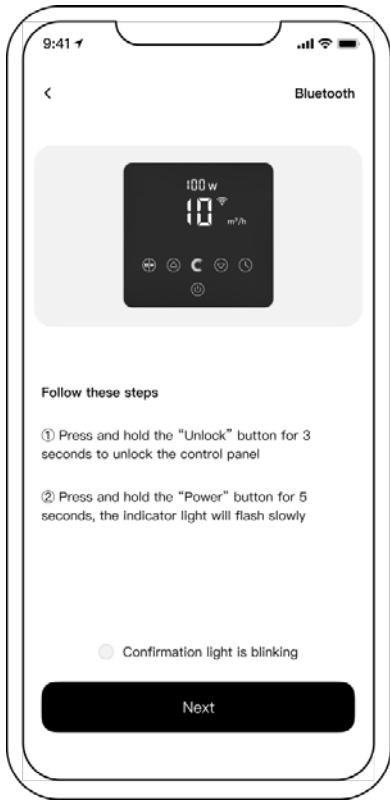

4 Operation

1) Auto Inverter mode (AI mode) :

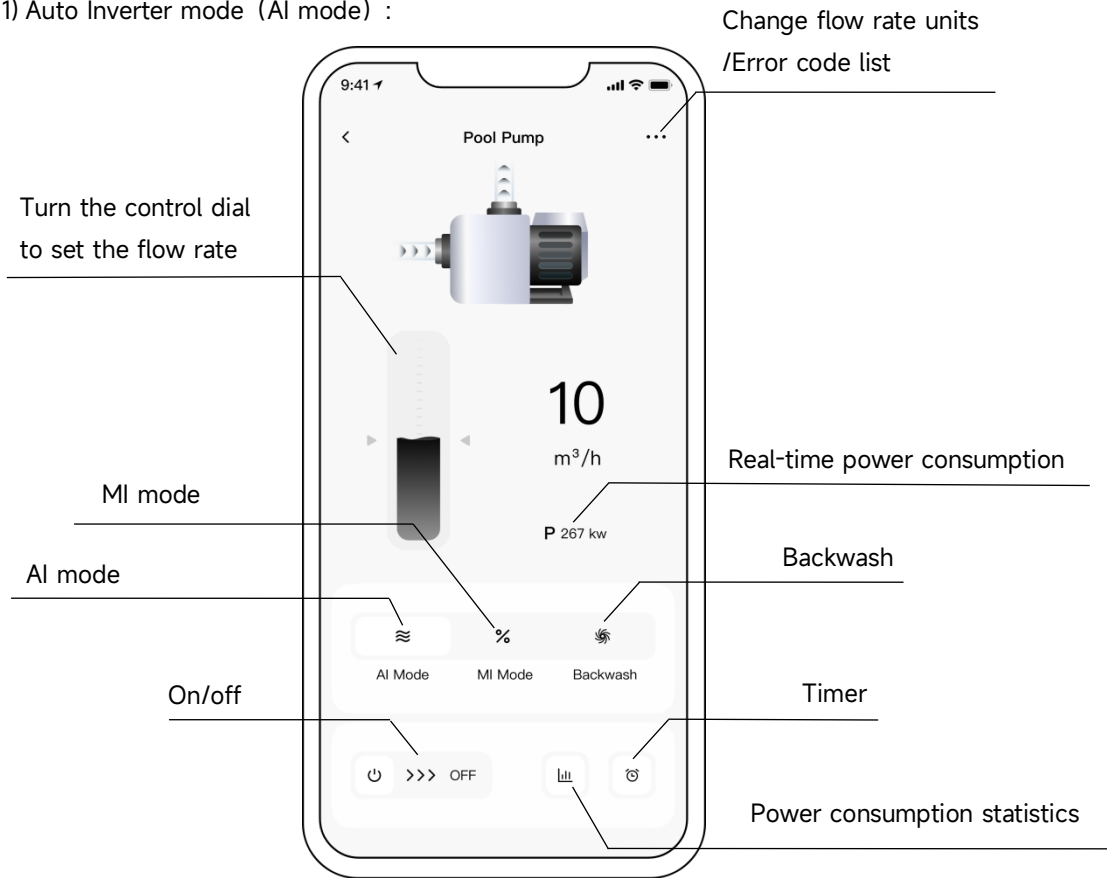

2) Manual Inverter mode (MI mode) :

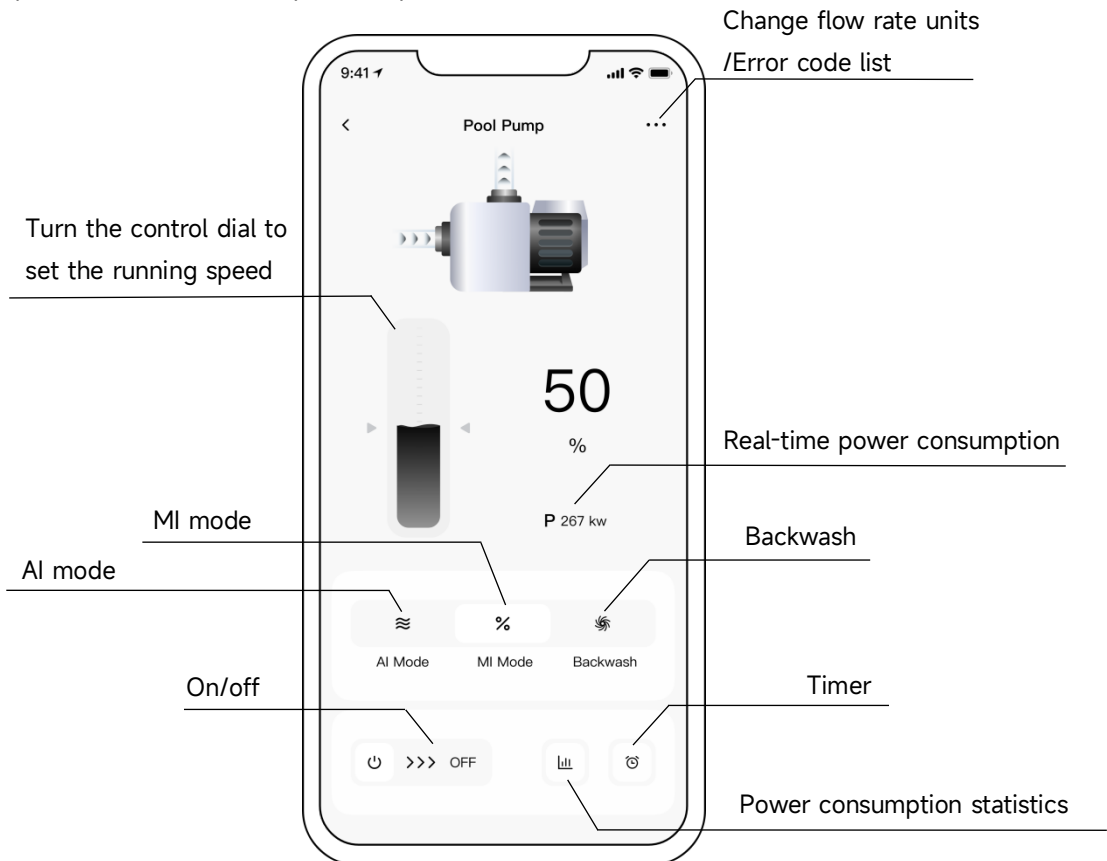

3) Backwash mode :

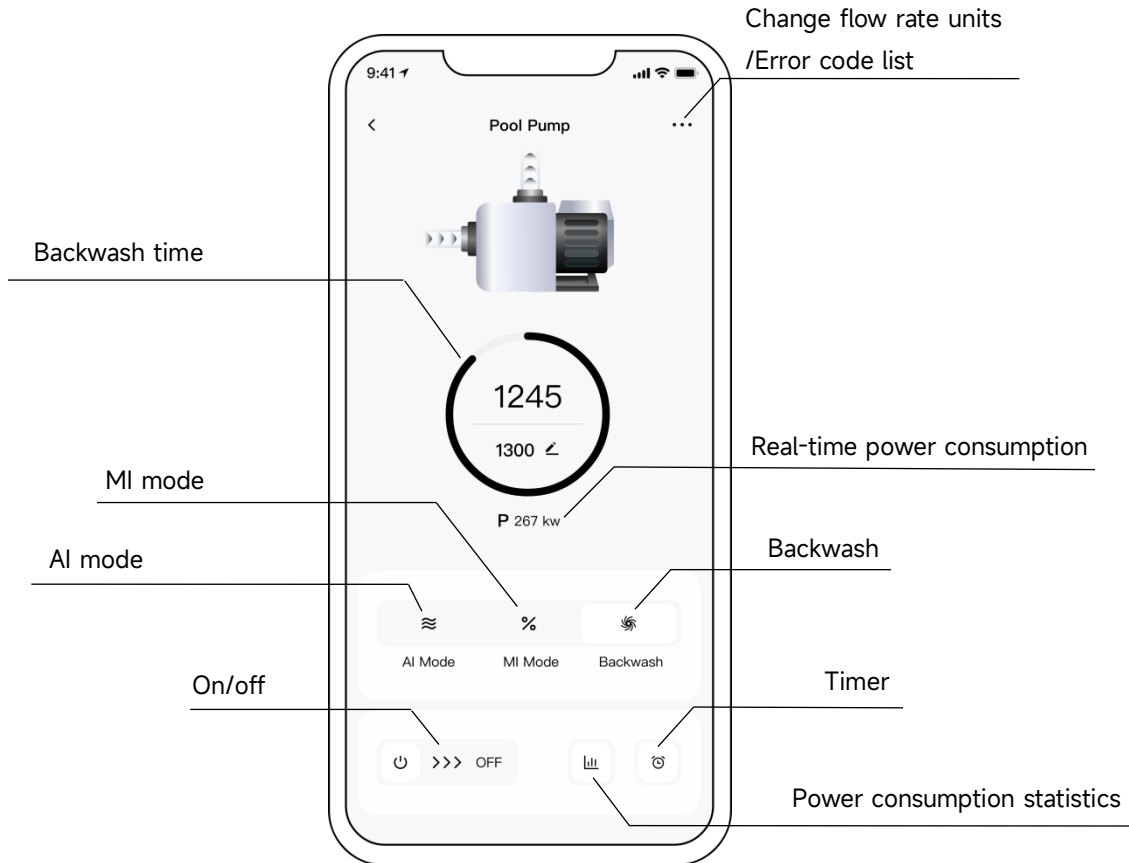

Notice for the timer setting via the APP :

- ⑦ Time variance is $\pm 30s$;
- ⑧ In order to avoid overlapping timing points conflicting and invalidating due to network delay, it is recommended that the end time and the start time of the next timing period cannot overlap, and a sufficient time interval should be reserved, for example, at least 2 minutes;

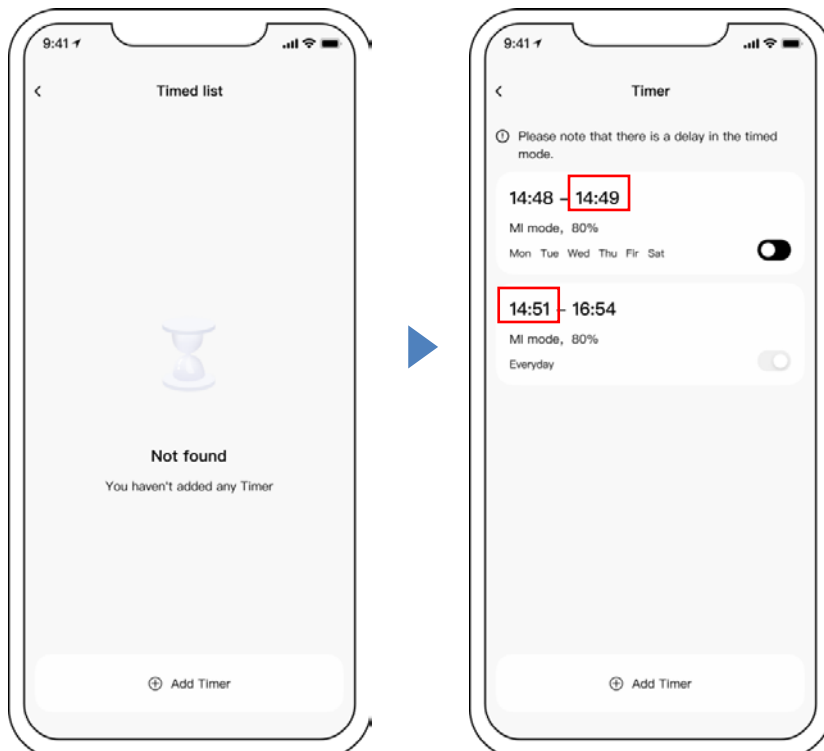

5 Sharing Devices with your family members

Users can share the devices to be controlled by their family members. Please let your family members register “iGarden” first, and then the administrator can operate as below:

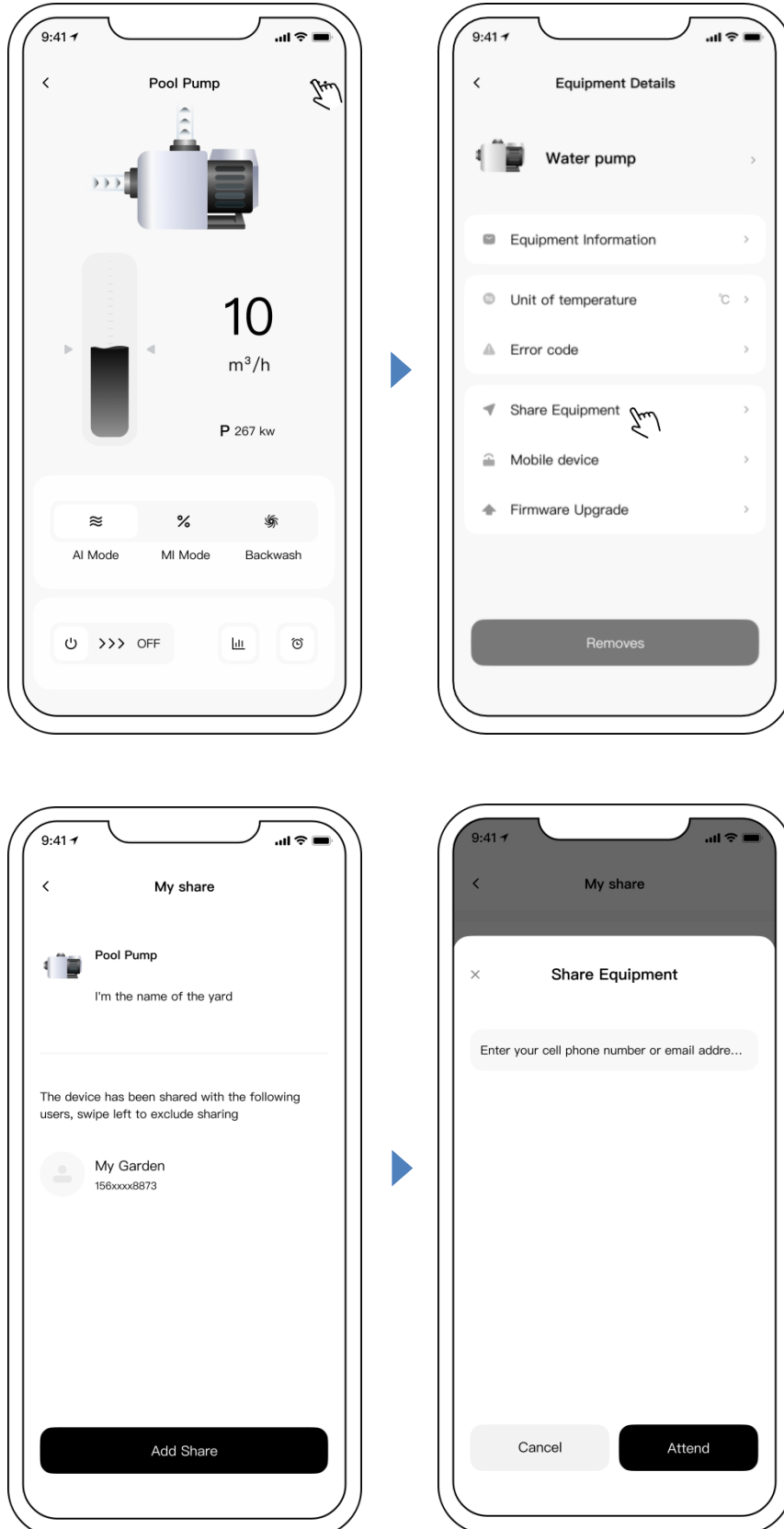

6 Garden Management

In the device list, the current courtyard is displayed. After clicking, users can view/switch to all the current courtyards, click Garden Management, and also enter the courtyard list page. As shown below:

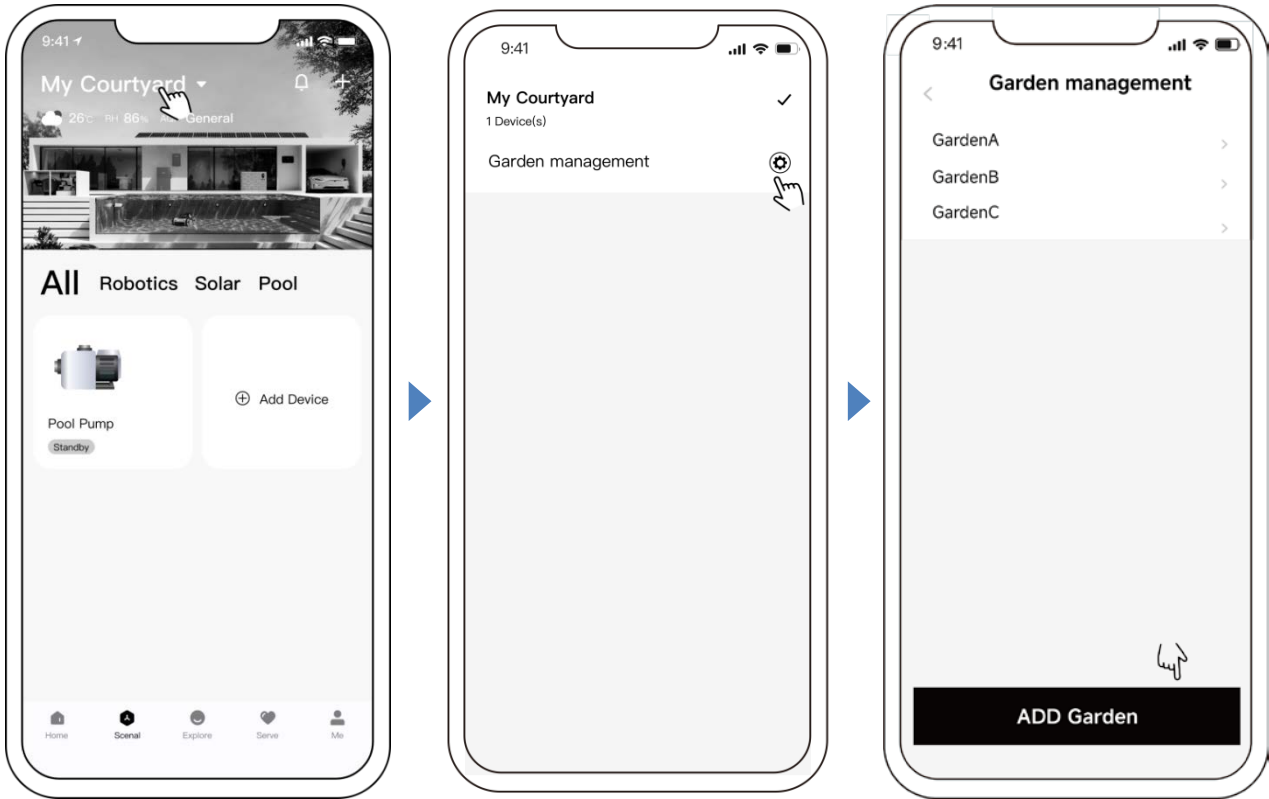

7 Message Center

A: View Message: On the device list page, click the message icon to enter the message center and view the corresponding message, as shown below: (Including: Alarm,Garden,Notify)

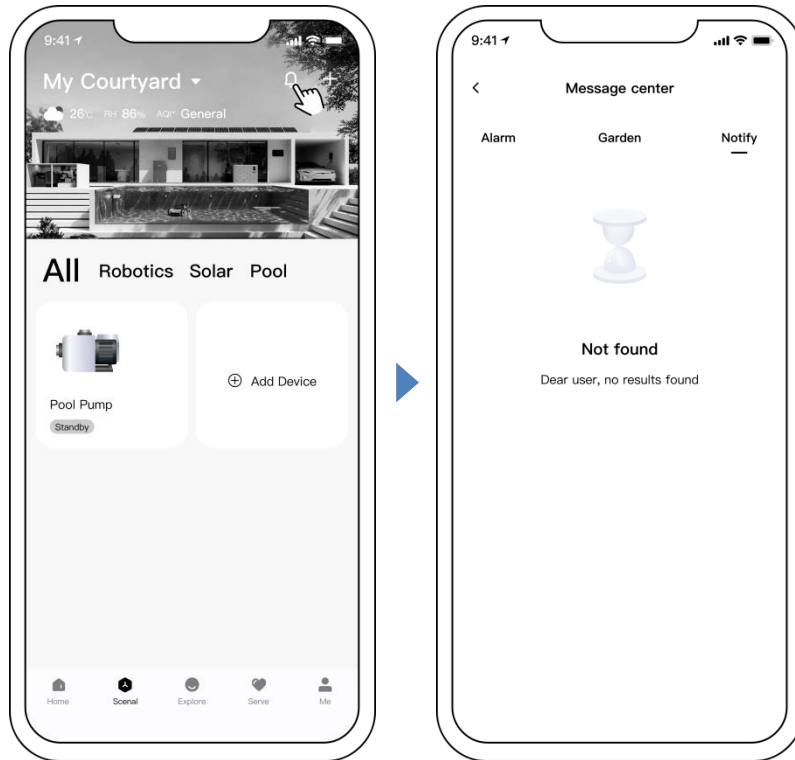

B: Push Settings: On the Settings page, click [Push Settings] to enter the Push Settings page. Users can set the push settings according to the message classification, as shown below:

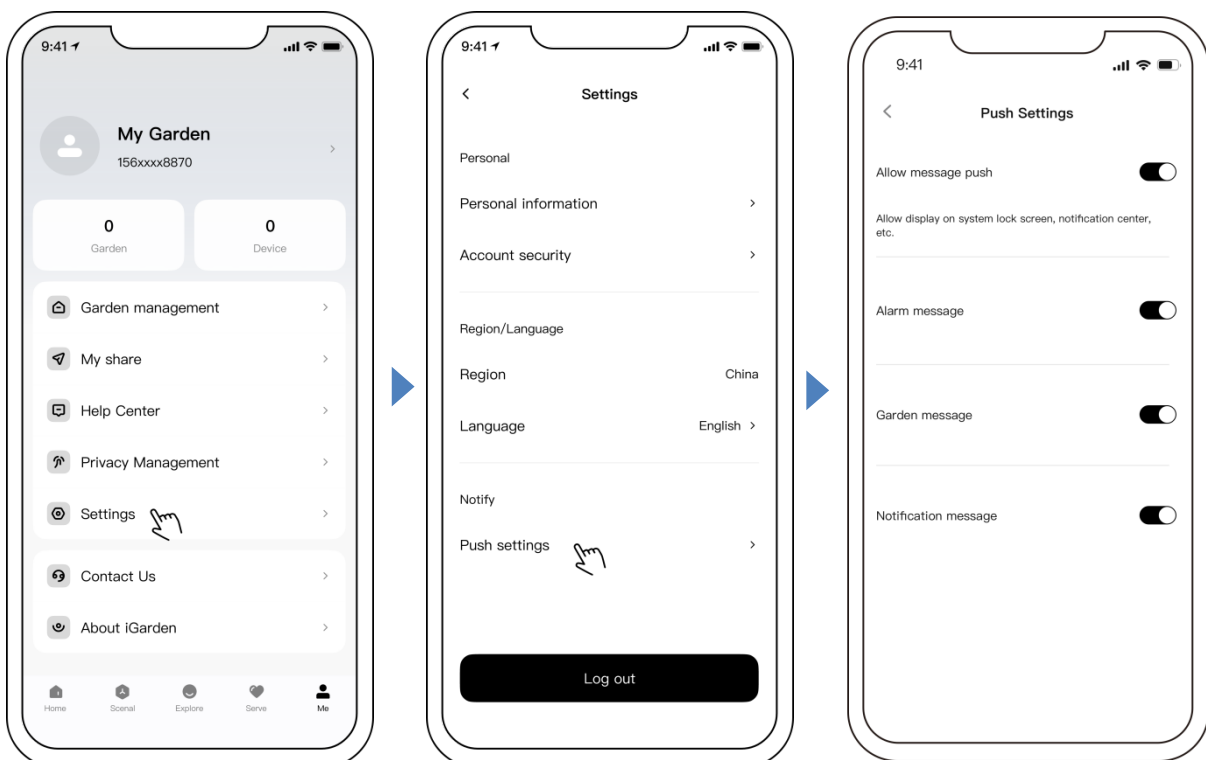

If you have any problem while using, welcome to send feedback to us. The process is as follows:

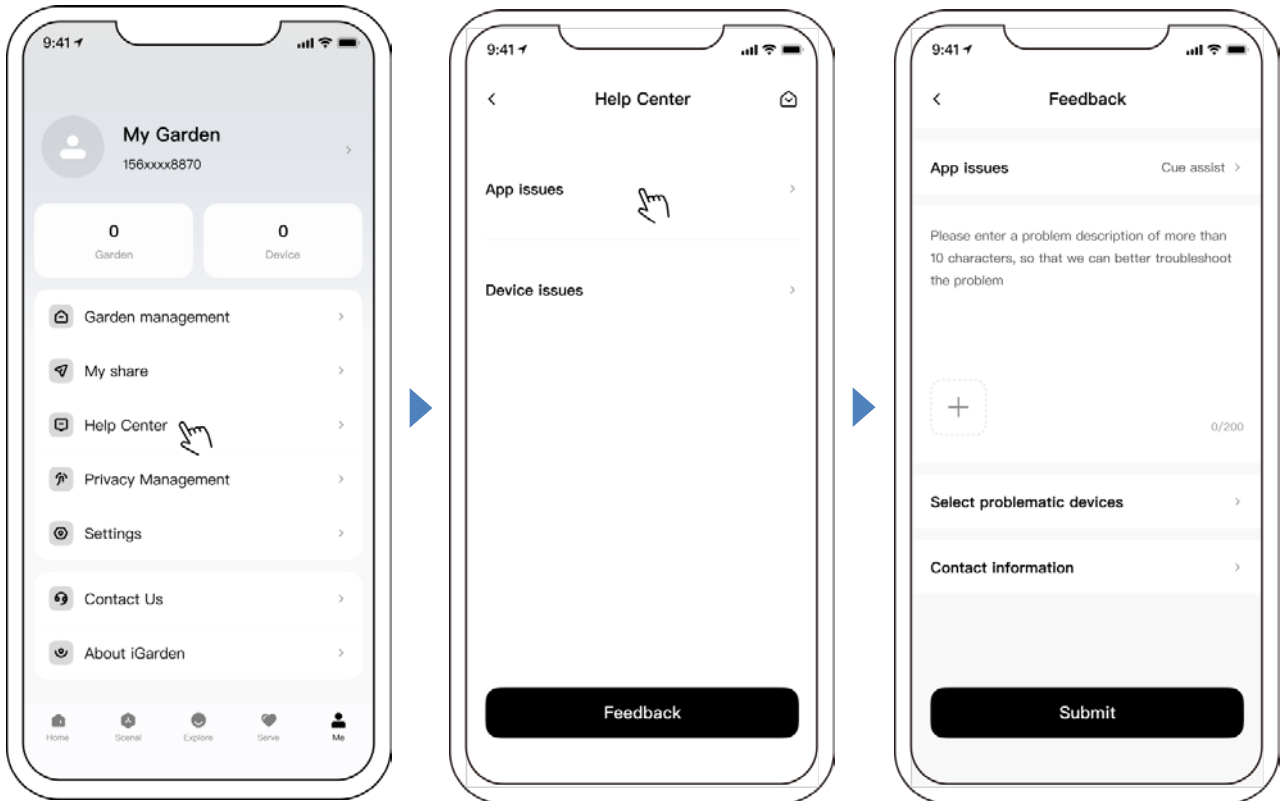

Notice:

- 1) The weather forecast is just for reference;
- 2) The power consumption data is for reference only, as it may be affected by network problems and imprecision of the calculation;
- 3) The App is subject to updates without notice.

7. EXTERNAL CONTROL

External control can be enabled via following contacts. If more than one external control is enabled, the priority is as below: Digital Input > RS485 > Panel control

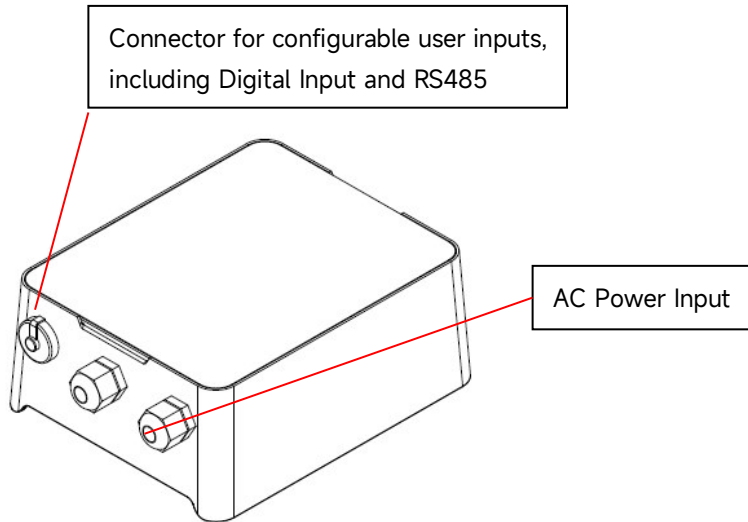

Figure 5 - Connector port location

AC Power Input (Suitable for 115V and 230V)

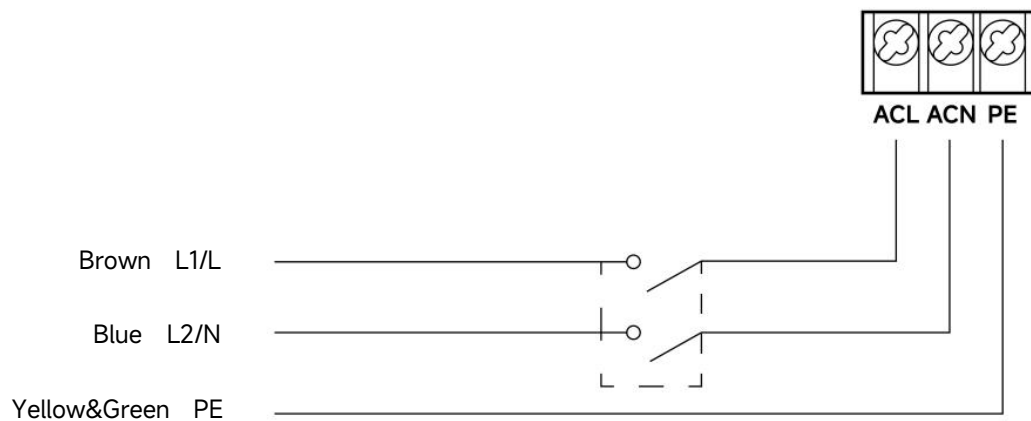

Figure 6 - Power cord connection

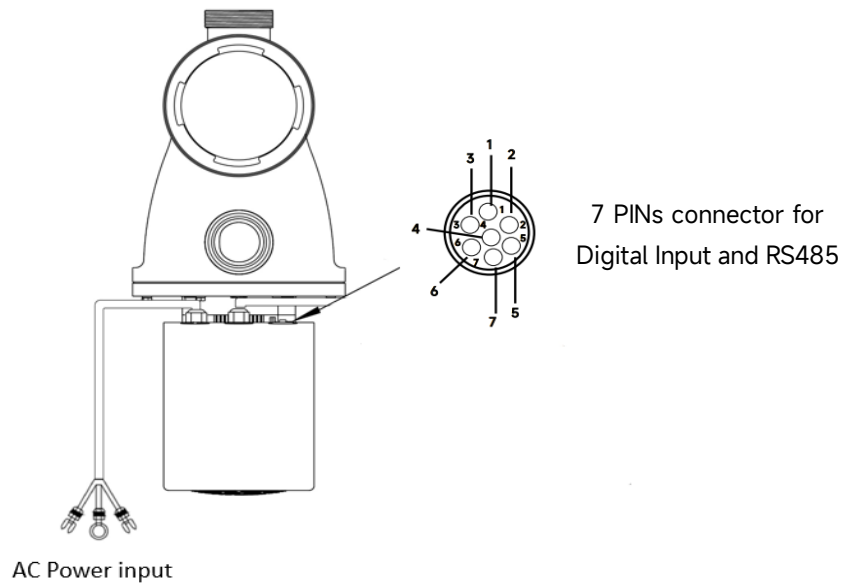

Figure 7 - Digital Input and RS485 connector

External Control	Color	Description	Note
Digital Input	Red	Di4 (Digital Input 4)	Default speed=40%
	Black	Di3 (Digital Input 3)	Default speed=80%
	White	Di2 (Digital Input 2)	Default speed=100%
	Grey	Di1 (Digital Input 1)	Stop
	Yellow	Digital Ground (COM)	COM
RS485	Green	RS485-A	/
	Brown	RS485-B	/

a. Digital Input

Running capacity is determined by the state of digital input,

- 1) When Di1(Grey) connects with COM(Yellow), the pump will be mandatory to stop; if disconnected, the digital control will be invalid;
- 2) When Di2(White) connects with COM(Yellow), the pump will be mandatory to run at 100%; if disconnected, the control priority will be back on panel control;
- 3) When Di3(Black) connects with COM(Yellow), the pump will be mandatory to run at 80%; if disconnected, the control priority will be back on panel control;
- 4) When Di4(Red) connects with COM(Yellow), the pump will be mandatory to run at 40%; if disconnected, the control priority will be back on panel control;
- 5) The capacity of inputs (Di2/Di3/Di4) could be modified according to the parameter setting.

b. RS485

To connect with RS485-A(Green) and RS485-B(Brown), the pump could be controlled via Modbus 485 communication protocol.

8. PROTECTION AND FAILURE

8.1. High-Temperature Warning and Speed Reduction - AL01

In "Auto Inverter/Manual Inverter Mode" and "Timer mode" (except backwash/self-priming), when the module temperature reaches the high-temperature warning trigger threshold (81°C), it enters the high-temperature warning state; when the temperature drops to the high-temperature warning release threshold (78°C), the high-temperature warning state is released. The display area alternately displays AL01 and running speed or flow.

If AL01 is displayed, the running capacity will be automatically reduced as below:

- 1) If current operating capacity is higher than 100%, the running capacity will be automatically reduced to 85%;
- 2) If current operating capacity is between 85% and 100%, the running capacity will be automatically reduced by 15%;
- 3) If current operating capacity is between 70% and 85%, the running capacity will be automatically reduced by 10%;
- 4) If current operating capacity is lower than 70%, the running capacity will be automatically reduced by 5%.

8.2. Undervoltage protection - AL02

The device is compatible with both 230V and 115V AC power input.

① AC Power Input: 230V

When the device detects that the input voltage is less than 198V, the device will limit the current running speed. The display area alternately displays AL02 and running speed or flow.

- 1) When the input voltage is less than or equal to 180V, the running capacity will be limited to 70%;
- 2) When the input voltage range is within 180V - 190V, the running capacity will be limited to 75%;
- 3) When the input voltage range is within 190V - 198V, the running capacity will be limited to 85%.

② AC Power Input: 115V

When the device detects that the input voltage is less than 98V, the device will limit the current running speed. The display area alternately displays AL02 and running speed or flow.

- 1) When the input voltage range is within 85V - 90V, the running capacity will be limited to 75%;
- 2) When the input voltage range is within 90V - 98V, the running capacity will be limited to 85%.

Note: If the input voltage is less than 85V, error code E001 (Abnormal Input Voltage, see 8.4) will be displayed.

8.3. Troubleshooting

Problem	Possible causes and solution
Pump does not start	<ul style="list-style-type: none"> • Power Supply fault, disconnected or defective wiring. • Fuses blown or thermal overload open. • Check the rotation of the motor shaft for free movement and lack of obstruction. • Because of a long time lying idle. Unplug the power supply and manually rotate motor's rear shaft a few times with a screwdriver.
Pump does not prime	<ul style="list-style-type: none"> • Empty pump/strainer housing. Make sure the pump/strainer housing is filled with water and the O ring of cover is clean. • Loose connections on the suction side. • Strainer basket or skimmer basket loaded with debris. • Suction side clogged. • Distance between pump inlet and liquid level is higher than 2m, the installation height of pump should be lowered.
Low Water Flow	<ul style="list-style-type: none"> • Pump does not prime. • Air entering suction piping. • Basket full of debris. • Inadequate water level in pool.
Pump being noisy	<ul style="list-style-type: none"> • Air leak in suction piping, cavitation caused by restricted or undersized suction line or leak at any joint, low water level in pool, and unrestricted discharge return lines. • Vibration caused by improper installation, etc. • Damaged motor bearing or impeller (need to contact the supplier for repair).

8.4. Error code

When the device detects a failure, it will stop automatically and display the error code. After stopping for 15 seconds, check if the failure is cleared. If cleared, the pump will resume working.

Item	Error Code	Details	
		Description	
1	E001	Description	Abnormal input voltage: the power supply voltage is out of the range of 165V to 275V.
		Process	The pump will stop automatically for 15 sec and resume working if it detects the power supply voltage is within the range.
2	E002	Description	Output over current: The peak current of the pump is higher than the protection current.

		Process	The pump will stop automatically for 15 sec and then resume working, if this occurs for three times continuously, the pump will shut down and need to be checked and restarted manually.
3	E102	Description	Heat sink error: The heat sink temperature reaches 91°C for 10sec. Or the heat sink sensor detects an open or short circuit.
		Process	1、 The pump will stop automatically for 30 sec and resume working if it detects the heat sink temperature is less than 81°C. 2、 The pump will stop automatically for 15 sec and resume working if it detects the heat sink sensor is not open or short circuit.
4	E103	Description	Master driver board error: The Master driver board is faulty.
		Process	The pump will stop automatically for 15 sec and then resume working, if this occurs for three times continuously, the pump will shut down and need to be checked and restarted manually.
5	E104	Description	Phase-deficient protection: Motor cables are not plugged into the master drive board.
		Process	The pump will stop automatically for 15 sec and then resume working, if this occurs for three times continuously, the pump will shut down and need to be checked and restarted manually.
6	E203	Description	RTC time reading error: Reading and writing the information of timer clock is incorrect.
		Process	The pump needs to be powered off and restarted manually.
7	E204	Description	Display Board EEPROM reading failure: Reading and writing the information of display board EEPROM is incorrect.
		Process	The pump needs to be powered off and restarted manually.
8	E205	Description	Communication Error: The communication between display board and master driver board is failure lasts 15 sec.
		Process	The pump will stop automatically for 15 sec and resume working if it detects the communication between display board and master driver board lasts 1 sec.
9	E207	Description	No water protection: The pump is lack of water.
		Process	Stop the pump manually, fill up the pump with water and restart it. If this occurs for twice continuously, the pump will shut down and need to be checked manually.
10	E209	Description	Loss of prime: The pump cannot self-priming due to the reasons such as exceeding the suction range or the pipeline is too complicated.

		Process	Check the pump or pipeline that there is no leakage, and then fill up the pump with water and restart it.
--	--	---------	---

9. MAINTENANCE

Empty the strainer basket frequently. The basket should be inspected through the transparent lid and emptied when there is an evident stack of rubbish inside. The following instructions should be followed:

- 1). Disconnected the power supply.
- 2). Unscrew the strainer basket lid anti-clockwise and remove.
- 3). Lift up the strainer basket.
- 4). Empty the trapped refuse from the basket and rinse out the debris if necessary.

Note: Do not knock the plastic basket on a hard surface as it will cause damage

- 5). Inspect the basket for signs of damage, and replace it.
- 6). Check the lid O-ring for stretching, tears, cracks or any other damage
- 7). Replace the lid, hand tightening is sufficient.

Note: Periodically inspecting and cleaning the strainer basket will help prolong its life.

10. WARRANTY & EXCLUSIONS

Should a defect become evident during the term of warranty, at its option, the manufacturer will repair or replace such item or part at its own cost and expense. Customers need to follow the warranty claim procedure in order to obtain the benefit of this warranty.

The guarantee will be void in cases of improper installation, improper operation, inappropriate use, tampering or using of non-original spare parts.

11. DISPOSAL



When disposing of the product, please sort the waste products as electrical or electronic product waste or hand it over to the local waste collection system.

The separate collection and recycling of waste equipment at the time of disposal will help ensure that it is recycled in a manner that protects human health and the environment.

Contact your local authority for information on where you can drop off your water pump for recycling.

CONTENU

1. ⚠️ CONSIGNES DE SÉCURITÉ IMPORTANTES	32
2. SPÉCIFICATIONS TECHNIQUES	33
3. DIMENSIONS GÉNÉRALES (mm)	33
4. INSTALLATION	34
5. RÉGLAGE ET FONCTIONNEMENT	37
6. FONCTIONNEMENT WI-FI (OPTIONNEL)	46
7. CONTRÔLE EXTERNE	55
8. PROTECTION ET DÉFAILLANCE	57
9. MAINTENANCE	60
10. GARANTIE ET EXCLUSIONS	60
11. ÉLIMINATION	61

MERCI D'AVOIR ACHETÉ NOS POMPES DE PISCINE À VARIATEUR DE FRÉQUENCE.

CE MANUEL CONTIENT DES INFORMATIONS IMPORTANTES QUI VOUS AIDERONT À UTILISER ET À ENTREtenir CE PRODUIT.

VEUILLEZ LIRE ATTENTIVEMENT CE MANUEL AVANT L'INSTALLATION ET LA MISE EN SERVICE, ET CONSERVEZ-LE POUR RÉFÉRENCE ULTÉRIEURE.

1. CONSIGNES DE SÉCURITÉ IMPORTANTES

Lors de l'installation et de l'utilisation de cet équipement électrique, il convient de toujours respecter les précautions de sécurité de base, notamment les suivantes :

- 1) LISEZ ET SUIVEZ TOUTES LES INSTRUCTIONS
- 2) AVERTISSEMENT – Afin de réduire les risques de blessure, ne laissez pas les enfants utiliser ce produit sans surveillance constante.
- 3) AVERTISSEMENT – Risque d'électrocution. Branchez uniquement à un circuit dérivé protégé par un dispositif à courant résiduel (DCR) dont le courant résiduel nominal ne dépasse pas 30 mA. Contactez un électricien qualifié si vous ne pouvez pas vérifier que le circuit est protégé par un dispositif à courant résiduel (DCR).
- 4) POUR ÉVITER TOUT RISQUE D'ÉLECTROCUTION, veuillez connecter le fil de terre du moteur (vert/jaune) au système de mise à la terre.
- 5) AVERTISSEMENT – Pour réduire les risques de choc électrique, remplacez immédiatement le cordon endommagé.
- 6) Ne pas installer dans un espace extérieur clos ou sous la jupe d'un spa ou d'un bain à remous.
- 7) Un sectionneur doit être installé sur l'installation électrique fixe conformément aux règles d'installation.
- 8) Pour une utilisation avec les piscines, les bains à remous et les spas.
- 9) ATTENTION : Pour réduire les risques d'électrocution, installez le dispositif à au moins 1,8 m des parois intérieures de la piscine. N'utilisez pas de rallonge.
- 10) ATTENTION : Pour assurer une protection continue contre les risques de choc électrique, utilisez uniquement des pièces de rechange identiques lors de l'entretien .
- 11) Cette pompe est conçue pour les piscines enterrées ou hors-sol fixes et peut également être utilisée avec les spas et jacuzzis dont la température de l'eau est inférieure à 50 °C . Du fait de son installation fixe, son utilisation est déconseillée pour les piscines hors-sol démontables.
- 12) La pompe n'est pas submersible.
- 13) N'ouvrez jamais l'intérieur du boîtier du moteur d'entraînement.
- 14) CONSERVEZ CES INSTRUCTIONS

⚠ AVERTISSEMENT :

- Remplissez la pompe d'eau avant de la mettre en marche. Ne la faites pas fonctionner à sec. En cas de fonctionnement à sec, le joint mécanique sera endommagé et la pompe fuira.
- Avant toute intervention sur la pompe, coupez l'alimentation électrique de celle-ci en débranchant le circuit principal et relâchez toute la pression de la pompe et du système de tuyauterie.
- Ne jamais serrer ni desserrer les vis pendant que la pompe est en marche.
- Assurez-vous que l'entrée et la sortie de la pompe ne sont pas obstruées par des corps étrangers.

2. CIFICATIONS TECHNIQUES

Modèle	Volume de piscine recommandé (m ³)	P1	Tension (V/Hz)	Qmax (m ³ /h)	Hmax (m)	Circulation (m ³ /h)	
		KW				À 10 m	À 8 m
DCP12-IG	40-70	1.2	220-240/ 50/60	28.0	21.0	23.0	26.0

3. DIMENSIONS GÉNÉRALES (mm)

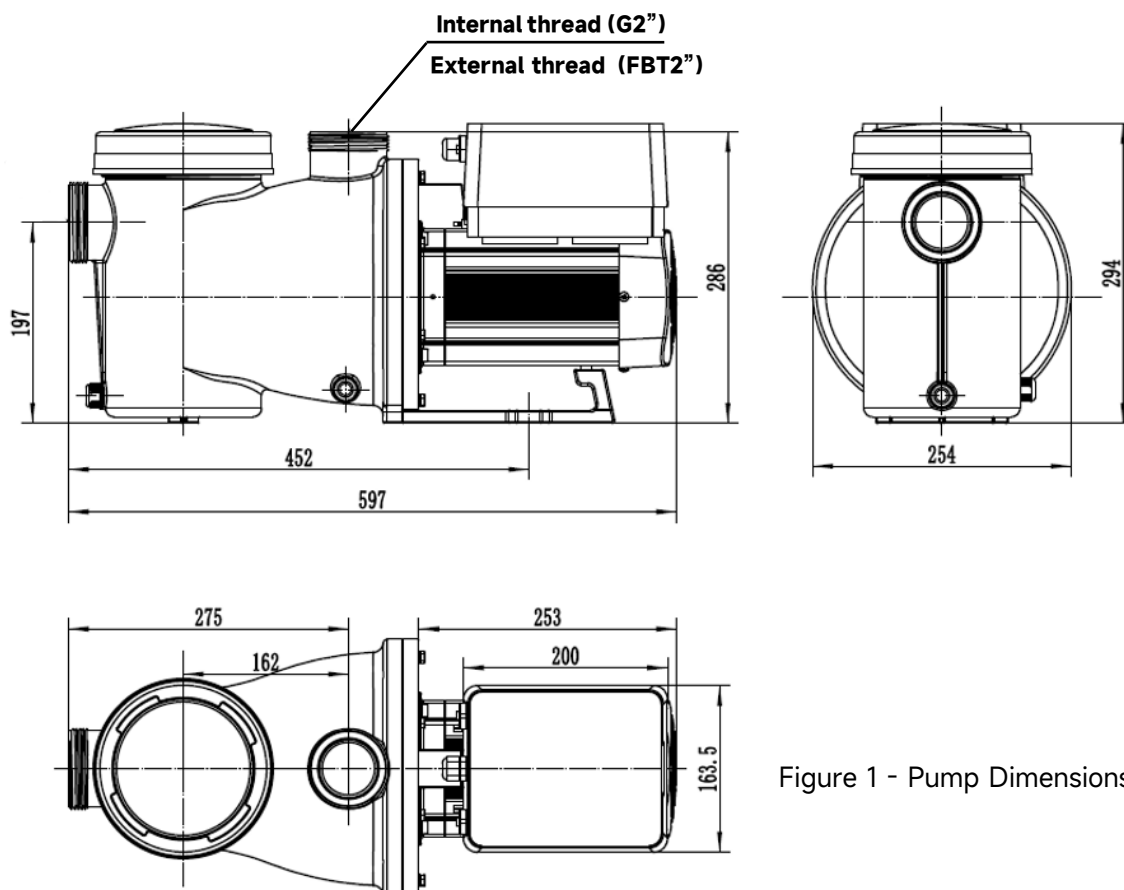

Figure 1 - Pump Dimensions

4. INSTALLATION

4.1 Emplacement de la pompe

- 1) Installez la pompe au plus près de la piscine afin de réduire les pertes par frottement et d'améliorer l'efficacité ; utilisez des tuyaux d'aspiration et de refoulement courts et directs.
- 2) Pour éviter l'exposition directe au soleil, à la chaleur ou à la pluie, il est recommandé de placer la pompe à l'intérieur ou à l'ombre.
- 3) N'installez pas la pompe dans un endroit humide ou mal ventilé. Maintenez la pompe et le moteur à au moins 150 mm des obstacles ; les moteurs de pompe nécessitent une bonne circulation d'air pour leur refroidissement.
- 4) La pompe doit être installée horizontalement et fixée dans l'orifice du support à l'aide de vis afin d'éviter tout bruit et vibration inutiles.

4.2 Plomberie et vannes

- 1) Taille du raccord d'entrée/sortie de la pompe : en option métrique (50 ou 63 mm) ou impériale (1,5 " ou 2") .
- 2) Pour optimiser la plomberie de la piscine, il convient d'utiliser des tuyaux de plus grand diamètre. Il est recommandé d'utiliser des tuyaux de 63mm.
- 3) Lors de l'installation des raccords d'entrée et de sortie (joints) avec la plomberie, utilisez le mastic spécial pour matériau PVC.
- 4) Le diamètre de la conduite d'aspiration doit être égal ou supérieur à celui de la conduite d'entrée, afin d'éviter que la pompe n'aspire de l'air, ce qui affecterait son rendement.
- 5) Pour réduire les pertes par frottement et améliorer l'efficacité, la tuyauterie côté aspiration et côté retour doit être courte et directe.
- 6) Les systèmes d'aspiration noyés doivent être équipés de vannes sur les conduites d'aspiration et de retour de la pompe, ce qui facilite la maintenance courante. Une vanne, un coude ou un té installé sur la conduite d'aspiration ne doit pas se trouver à une distance de l'avant de la pompe inférieure à sept fois le diamètre de la conduite d'aspiration.
- 7) Utilisez un clapet anti-retour sur la conduite de retour lorsqu'il existe une hauteur importante entre la conduite de retour et la sortie de la pompe, afin d'éviter que la pompe ne subisse l'impact de la recirculation du fluide et le coup de bélier qui l'arrête .

4.3 Raccords

1. Les coudes doivent être installés à au moins 350 mm de l'entrée. Ne pas installer de coudes à 90° directement sur l'entrée/sortie de la pompe. Les joints doivent être étanches.
2. Les articulations doivent être bien serrées.

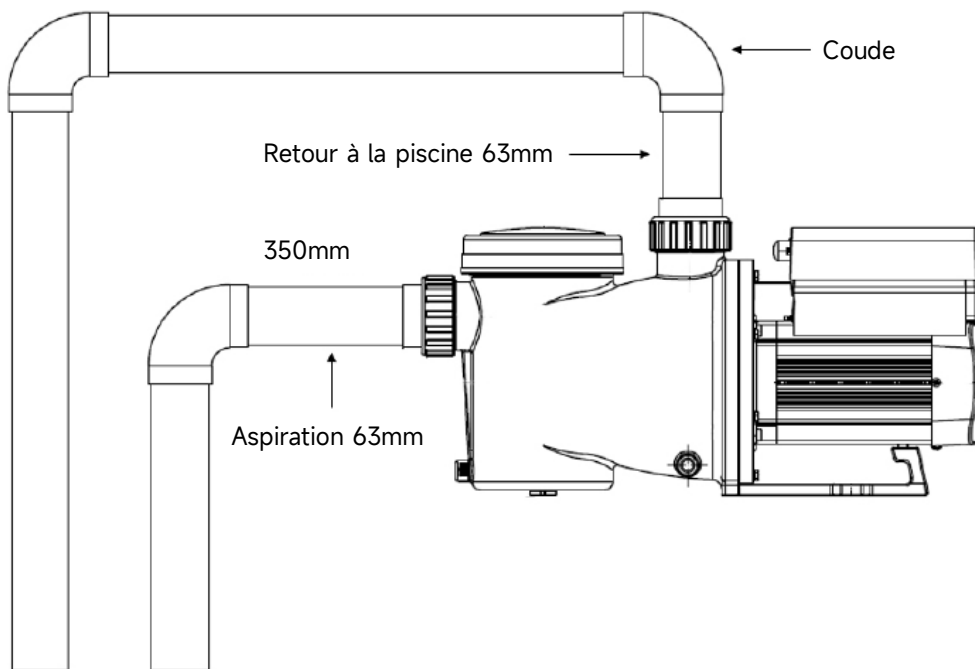

Figure 2 - Installations de plomberie et de raccords

* Taille du raccord d'entrée/sortie de la pompe : en option, métrique (50 ou 63 mm) ou impériale (1,5 ou 2 pouces).

3. Utilisez le kit de raccord fourni par le fabricant de la pompe (voir figure 3). N' utilisez pas d' autres raccords pour connecter l' entrée/sortie de la pompe, car ils pourraient être incompatibles et endommager le corps de la pompe.

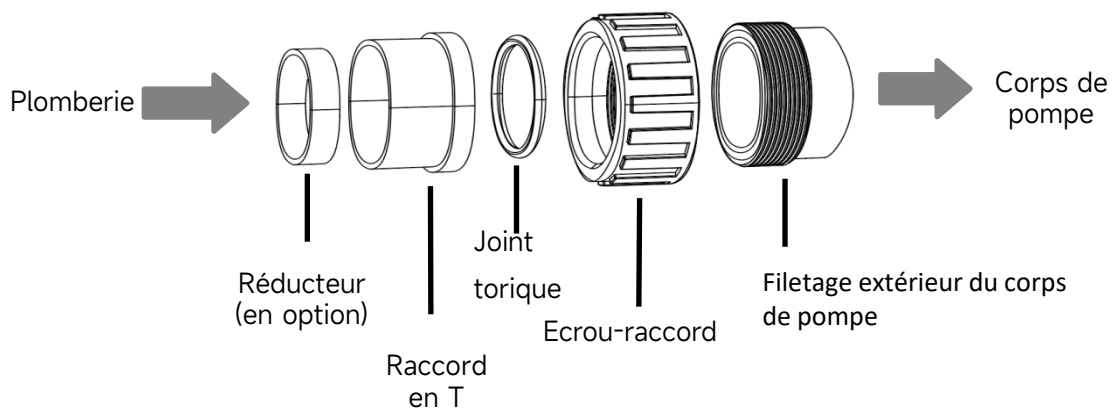

Figure 3 - Union Kit

4.4 Vérifier avant le démarrage initial







- 1) Vérifiez si l'arbre de la pompe tourne librement ;
- 2) Vérifiez si la tension et la fréquence de l'alimentation électrique sont conformes aux indications de la plaque signalétique ;
- 3) Face à la pale du ventilateur, le sens de rotation du moteur doit être horaire ;
- 4) Il est interdit de faire fonctionner la pompe sans eau.

4.5 Conditions d'application

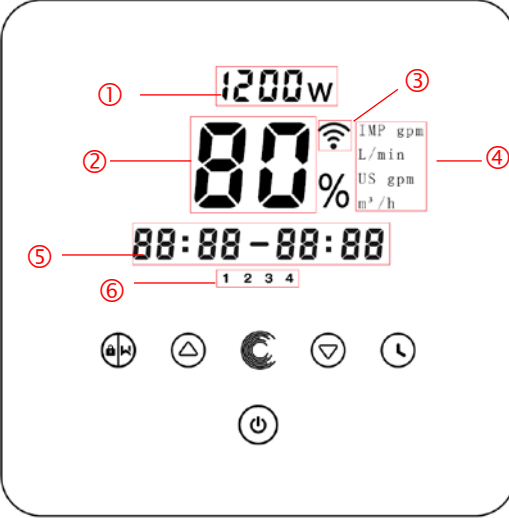
Température ambiante	Installation intérieure, plage de température : -10 à 42 °C
température maximale de l'eau	50°C
Eau salée disponible	Concentration en sel jusqu'à 3,5 %, soit 35 g/l
Humidité	≤90% HR, (20°C±2°C)
Installation	La pompe peut être installée à une hauteur maximale de 2 m au-dessus du niveau de l'eau.
Protection	Classe F, IP55

5. RÉGLAGE ET FONCTIONNEMENT



5.1 Affichage sur le panneau de commande

	① Consommation d'énergie
	② Capacité de fonctionnement / Débit
	③ Indicateur Wi-Fi (en option)
	④ Unité de débit
	⑤ Période de temporisation
	⑥ Minuteur 1/2/3/4
	 Lavage à contre-courant/déverrouillage
	 Haut/bas : pour modifier la valeur du paramètre
	 Basculer entre le mode manuel et le mode manuel Mode onduleur et Auto Mode onduleur. Manuel Mode onduleur : La capacité de fonctionnement sera réglée manuellement entre 30 % et 120 %. Auto Mode Inverter : La capacité de fonctionnement sera automatiquement ajustée entre 30 % et 120 % en fonction du débit prédéfini. Le mode par défaut est Manuel Onduleur mode.
	 Réglage de la minuterie
 Marche/arrêt	

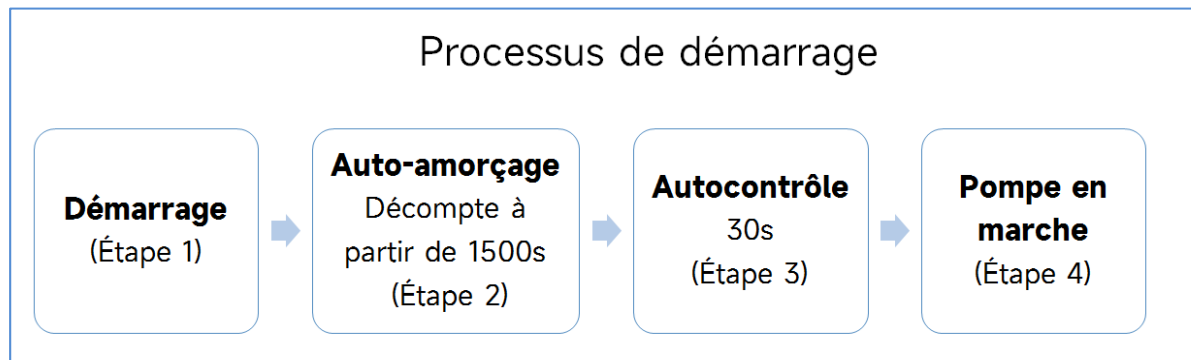
5.2 Démarrer processus aperçu



① Étape 1 : Démarrage

- Maintenez la pression  pendant plus de 3 secondes pour déverrouiller l'écran .
- Presse  à démarrer le pompe.

② Étape 2 : Auto - amorçage

- Le pompe commencera Le compte à rebours commence à 1500 secondes ; lorsque le système détecte que la pompe est pleine d'eau, il arrêtera le compte à rebours et sortira automatiquement de l'amorçage.
- Les utilisateurs peuvent accéder au paramétrage pour désactiver la fonction d'amorçage automatique par défaut (voir 5.11) .



③ Étape 3 : Auto - vérification

- Le pompe Nous allons vérifier pendant 30 secondes pour nous assurer que l'auto-amorçage (étape 2) est terminé .

④ Étape 4 : Pompe en cours d'exécution

- La pompe fonctionnera à 80 % de sa capacité nominale lors du démarrage initial après l'auto-amorçage.

5.3 Démarrer

Lorsque l'appareil est allumé, l'écran s'allumera. Lorsque l'écran s'allume complètement pendant 3 secondes, le code de l'appareil s'affiche, puis celui-ci passe en mode de fonctionnement normal. Lorsque l'écran est verrouillé, seul le bouton  L' écran s'allume ; maintenez la pression  pendant plus de 3 secondes pour le déverrouiller . L'écran se verrouille automatiquement après une minute d'inactivité et sa luminosité est réduite à un tiers. Appuyez brièvement  pour le réactiver et consulter les paramètres de fonctionnement.

5.4 Auto-amorçage

À chaque démarrage de la pompe , celle-ci s'auto-amorcera .

Lorsque la pompe fonctionne auto-amorçage, il effectuera un compte à rebours au démarrage à partir de 1500 secondes et s'arrête automatiquement lorsque le système détecte que la pompe est pleine d'eau, puis le système effectuera une nouvelle vérification pendant 30 secondes pour s'assurer que l'auto-amorçage est terminé .



L'utilisateur peut annuler manuellement l'amorçage automatique en appuyant sur  pendant plus de 3 secondes . La pompe passera alors en mode Inverter manuel par défaut lors du démarrage initial.

Remarque:

la fonction d'auto-amorçage activée. À chaque redémarrage, elle s'auto-amorce automatiquement. L' utilisateur peut désactiver cette fonction par défaut dans les paramètres (voir section 5.11) .

5.5 Remous











L' utilisateur peut démarrer le lavage à contre-courant ou la recirculation rapide dans n'importe quel état de fonctionnement en appuyant sur .

	Défaut	Plage de réglage
Temps	années 180	Appuyez sur  ou  pour régler de 0 à 1500 s, avec 30 secondes par étape.
capacité de fonctionnement	100%	60-100%, entrez le réglage du paramètre (voir 5.11)

de sortie :

Lorsque le mode de lavage à contre-courant est activé, l'utilisateur peut maintenir le bouton enfoncé  pendant 3 secondes pour l'annuler ; la pompe reprendra alors son état précédent . Si l'utilisateur a défini une limite de vitesse, le débit du lavage à contre-courant ne dépassera pas cette limite (voir 5.10) .

5.6 Manuel Mode onduleur













1		Maintenez la pression  pendant plus de 3 secondes pour déverrouiller l'écran .
2		Appuyez  pour démarrer. La pompe fonctionnera à 80 % de sa capacité nominale lors du démarrage initial après l'auto-amorçage.
3	 	Appuyez sur  ou  pour régler la capacité de fonctionnement entre 30 % et 120 %, chaque étape étant de 5 % .
4		Appuyez  de nouveau pour passer en mode Auto Inverter.

Note :

- 1) Lorsque la pression dans la canalisation est élevée, pour maintenir un débit adéquat, l'utilisateur peut régler la capacité de fonctionnement entre 105 % et 120 %. La pompe fonctionnera alors à une vitesse plus élevée pour compenser la pression élevée dans la canalisation.
- 2) Dans la plage de fonctionnement de 105 % à 120 % de la capacité, la pompe ajustera automatiquement sa vitesse lorsqu'elle atteindra sa puissance maximale.
- 3) Par exemple, lorsque l'utilisateur règle la vitesse à 110 %, si la pompe La puissance ayant atteint sa valeur maximale à cette vitesse , même si l'utilisateur continue d'augmenter la vitesse de la pompe à 120 % , celle-ci maintiendra sa vitesse à la puissance maximale, soit 110 %. La vitesse affichée passera alors de 120 % à 110 %.

5.7 Auto Mode onduleur

En mode Auto Inverter, la pompe peut détecter automatiquement la pression du système et ajuster la vitesse du moteur pour atteindre le débit défini.

1		Déverrouillez l'écran, appuyez  pour passer du mode onduleur manuel au mode onduleur automatique.
2	 	Le débit pouvait être ajusté, en appuyant  ou  par paliers de 1 m ³ /h .
3	 	L'unité de débit peut être modifiée en L /min , IMP gpm ou US gpm en appuyant simultanément sur les deux touches.   pendant 3 secondes .
4		Appuyez  pour passer en mode onduleur manuel .

La plage de débit réglable par défaut pour InverK est la suivante :

Modèle	Plage de débit réglable *
DCP12-IG	8-25 m ³ /h

*** Note :**











En mode Auto Inverter, le débit maximal réglable est basé sur une hauteur manométrique d'environ 8 m.

Si l'utilisateur règle le débit au débit maximal réglable et que la pression dans la canalisation est supérieure à 8 m, la pompe augmentera automatiquement sa vitesse de fonctionnement et sa puissance d'entrée pour faire face à la haute pression et maintenir le débit maximal défini par l'utilisateur.

Lorsque la vitesse du moteur et la puissance d'entrée augmentent au niveau maximal mais que cela ne suffit pas à contrer l'énorme pression de la canalisation, le débit affiché sur le contrôleur de pompe diminuera du débit réglé au débit réellement réalisable .

5.8 Mode minuterie





La mise en marche/arrêt et le débit de la pompe pourraient être commandés par un une minuterie, programmable quotidiennement selon les besoins.

1	Accédez au réglage de la minuterie en appuyant sur 
2	Appuyez sur  ou  pour régler l'heure locale
3	Appuyez  pour confirmer et passer au réglage de l'heure 1
4	Presse  ou  de choisir les périodes de fonctionnement , la capacité de fonctionnement ou le débit souhaités (Lorsque l'icône % clignote, les utilisateurs peuvent modifier le débit en appuyant sur la touche correspondante )
5	 Répétez les étapes ci-dessus pour paramétrer le autres 3 fois
6	 Maintenez la pression pendant 3 secondes pour enregistrer le réglage et activer le mode minuterie.
7	 ou  vérifiez 4 minuteurs pour vous assurer qu'il n'y a pas de paramètre invalide.

Note:



1) Si la période programmée inclut l'heure actuelle, la pompe démarrera en fonction du débit ou de la capacité de fonctionnement programmés , selon l' indicateur de minuterie actuel . 1 2 3 4 (1, 2, 3



ou 4) s'illumineront , et la zone **00:00 - 00:00** affichera la période correspondante .

- 2) si la période définie ne contient pas l'heure actuelle, le numéro de minuterie 1 2 3 4 Le numéro (1, 2, 3 ou 4) sur le point de démarrer s'affichera et clignotera , ainsi que la zone. **00:00 - 00:00** affichera la période correspondante .
- 3) Lors du réglage de la minuterie, si vous souhaitez revenir au réglage précédent, maintenez les deux boutons enfoncés  . Maintenez la touche enfoncée pendant 3 secondes. Si vous n'avez pas besoin de régler les 4 minuteurs, maintenez-la enfoncée  pendant 3 secondes; le système enregistrera automatiquement la valeur actuelle et activera le mode minuteur.
- 4) Les réglages de minuterie de la pompe ont été limités ; les utilisateurs ne pourront pas régler les minuterie qui se chevauchent.
- 5) Une fois la minuterie réglée, si l'utilisateur éteint la pompe, lorsqu'il la rallume, elle revient automatiquement en mode minuterie.
- 6) Les utilisateurs peuvent annuler le mode minuterie en appuyant sur .

5.9 Écumeur Mode

Le mode écumeur permet à la pompe d'écumer la surface de l'eau, empêche l'accumulation de débris et offre aux utilisateurs une piscine plus propre.

Maintenez la touche  enfoncée  pour accéder à l'interface prédéfinie du mode skimmer. Lors du premier passage à ce mode, le préréglage 1 sera activé.

Les utilisateurs peuvent appuyer sur  ou  pour afficher les 4 préréglages, les détails de chaque préréglage sont ci-dessous, le préréglage sélectionné sera activé après 5 secondes sans opération.

Préinitialisation	Skimmer	Durée du skimmer	Vitesse Skimmer	Période	Remarque
1	1 h	3 minutes	100%	7:00 - 21:00	Modifiable dans paramétrage
2	1 h	10 min	100%	7:00 - 21:00	Non modifiable
3	3 h	3 minutes	80%	7:00 - 21:00	Non modifiable
4	Désactivez le mode écumeur				Non modifiable

Tableau 1 - Préréglages du mode écumeur

Pendant la durée de l'écumeur, le contrôleur affichera le paramètre préréglé, l'utilisateur peut maintenir  Maintenez la pression pendant 3 secondes pour annuler la durée de l'écumeur. Une fois cette durée écoulée, la pompe reprend son fonctionnement normal .

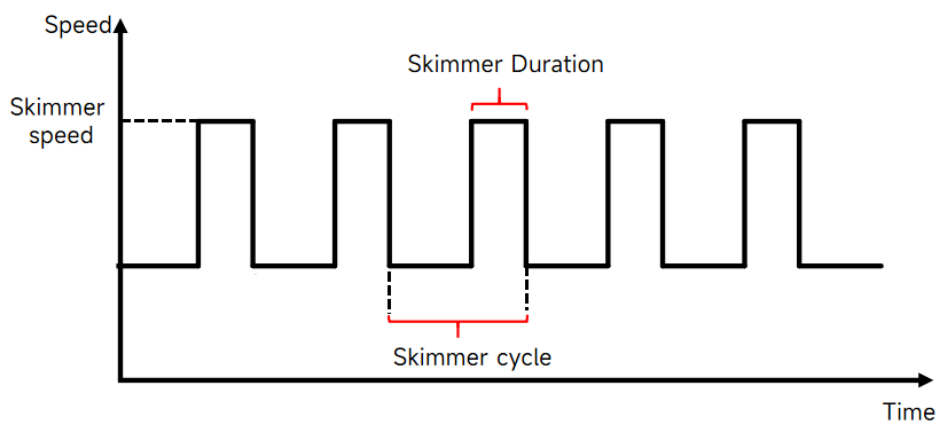
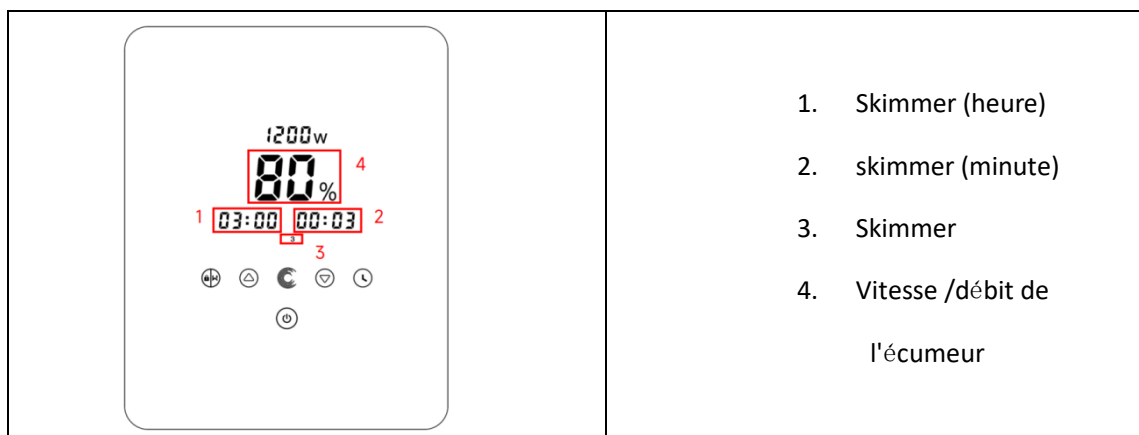

Figure 4 - Cycle du skimmer

5.10 Limite de vitesse /débit

Les utilisateurs peuvent régler la limite de vitesse /débit de la pompe pour répondre aux exigences de débit d'autres équipements tels que les filtres à sable.









limite de vitesse / débit de la pompe peut être réglée dans les paramètres. (voir 5.11)



100 % signifie aucune limite de vitesse et la capacité de fonctionnement peut être réglée de 30 % à 120 % en fonctionnement normal.





Modèle	Limite de vitesse/débit	
	Vitesse de course maximale	Débit maximal
DCP12-IG	60 % à 100 %	15-25 m ³ /h

Pour garantir les performances, le processus d' auto -amorçage à chaque démarrage ne sera pas limité par la fonction de limitation de vitesse /débit .





5.11 Paramétrage

Restaurer les paramètres d'usine	Éteignez la pompe, puis maintenez les deux   pendant 3 secondes
Vérifiez la version du logiciel	Éteignez la pompe, puis maintenez les deux   pendant 3 secondes
Saisissez les paramètres comme ci-dessous	Éteignez la pompe, puis maintenez les deux   pendant 3 secondes ; Presse  pour sélectionner l'adresse du paramètre et appuyez sur  ou  pour ajuster le réglage du paramètre.

Paramètre Adresse	Description	Paramètres par défaut	Plage de réglage
1	Di2 (Entrée numérique 2)	Vitesse : 100 %	Vitesse : 30-120 %, par incréments de 5 % ;
2	Di3 (Entrée numérique 3)	Vitesse : 80 %	Débit : 1 m ³ /h incréments ; DCP12-IG : 8-25 m ³ /h incréments
3	Di4 (Entrée numérique 4)	Vitesse : 40 %	Note : Appuyez  à passer au flux taux paramètre .
4	Remous	Vitesse : 100 %	Vitesse : 60-100 % , par incréments de 5 % ; Débit : 1 m ³ /h incréments ; DCP12-IG : 8-25 m ³ /h Note : Appuyez  à passer au flux taux paramètre.
5	Mode de contrôle de l'entrée analogique	0	0 : Contrôle du courant 1 : Contrôle de la tension

6	Activer ou désactiver l' amorçage automatique à chaque démarrage	25	25 : permet 0 : désactive
7	Réservé	0	Non modifiable
8	Temps système	00:00	00:00 - 23:59
9	Préinitialiser 1 du mode écumeur	Cycle Skimmer : 01:00 Durée du skimmer : 00:03 Vitesse du skimmer : 100 %	*Cycle Skimmer : 1 - 24 h, 1 h pour chaque étape ; * Durée du Skimmer : 1 à 30 min, 1 min pour chaque étape ; *Vitesse du Skimmer S : 30 % à 100 %, par incréments de 5 % ; *Débit du Skimmer : de 1 m ³ /h incréments ; DCP12-IG : 8-25 m ³ /h  Note : Appuyez  à passer au flux taux paramètre.
10	Durée du pré réglage 1 du mode écumeur	7:00 – 21:00	Heure de début : 00:00 - 24:00 Heure de fin : 00:00-24:00
11	Limitation de vitesse	Vitesse : 100 %	Vitesse : 60 %-100 %, par incréments de 5 % ; (100 % signifie aucune limitation de vitesse) Débit : 1 m ³ /h incréments ; DCP12-IG : 15-25 m ³ /h  Note : Appuyez  à passer au flux taux paramètre .
12	Adresse RS485	170(0xAA)	160-190 (0xA0-0xBF), chaque étape par 1.
13	Réservé	0	Non modifiable

Par exemple : Comment activer / Désactiver la fonction d'auto-amorçage ?

- 1) Saisissez le paramètre : Éteignez la pompe, puis maintenez les deux   pendant 3 secondes ;
- 2) Sélectionnez l'adresse du paramètre : Appuyez  pour sélectionner l'adresse 6 ;
- 3) Activer ou désactiver la fonction d'amorçage automatique : Ajuster en appuyant sur  ou , 2 5=
Active, 0=Désactive .

6. FONCTIONNEMENT WI-FI (OPTIONNEL)

① Télécharger l'application iGarden



Android



iOS



② Enregistrement du compte

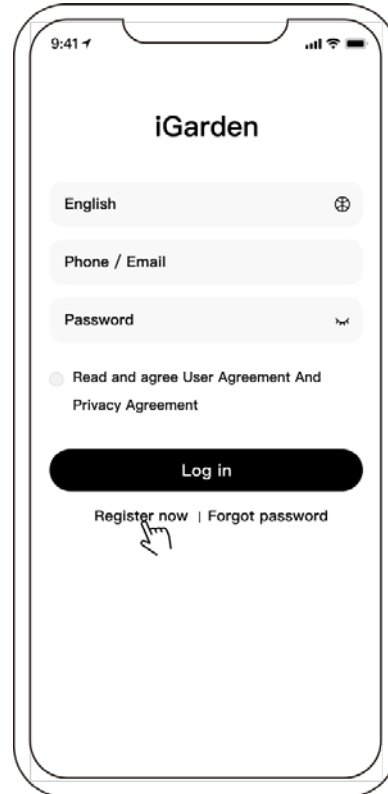

Inscription par téléphone/courriel

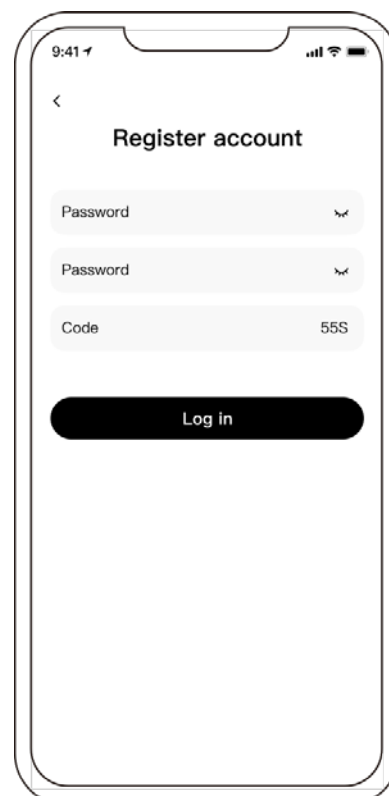
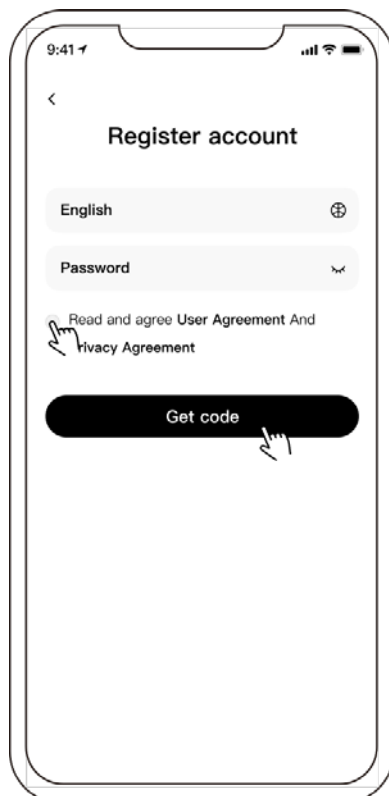



3 Appariement d'applications

Veuillez vous assurer que votre pompe est allumée avant de commencer.

(Conditions du réseau : 2,4 GHz ; les réseaux 2,4 GHz et 5 GHz sont combinés en un seul SSID ; mais il n'existe pas de réseau 5 GHz distinct)

1) Veuillez confirmer que votre téléphone est connecté au Wi-Fi et que le Bluetooth de votre téléphone est activé.

2) Appuyez  pendant 3 secondes pour déverrouiller l'écran. Après avoir allumé la pompe, appuyez  pendant 5 secondes jusqu'à entendre un bip, puis relâchez.  Le voyant clignotera.

3) Cliquez sur « Ajouter un appareil », puis suivez les instructions pour jumeler l'appareil.

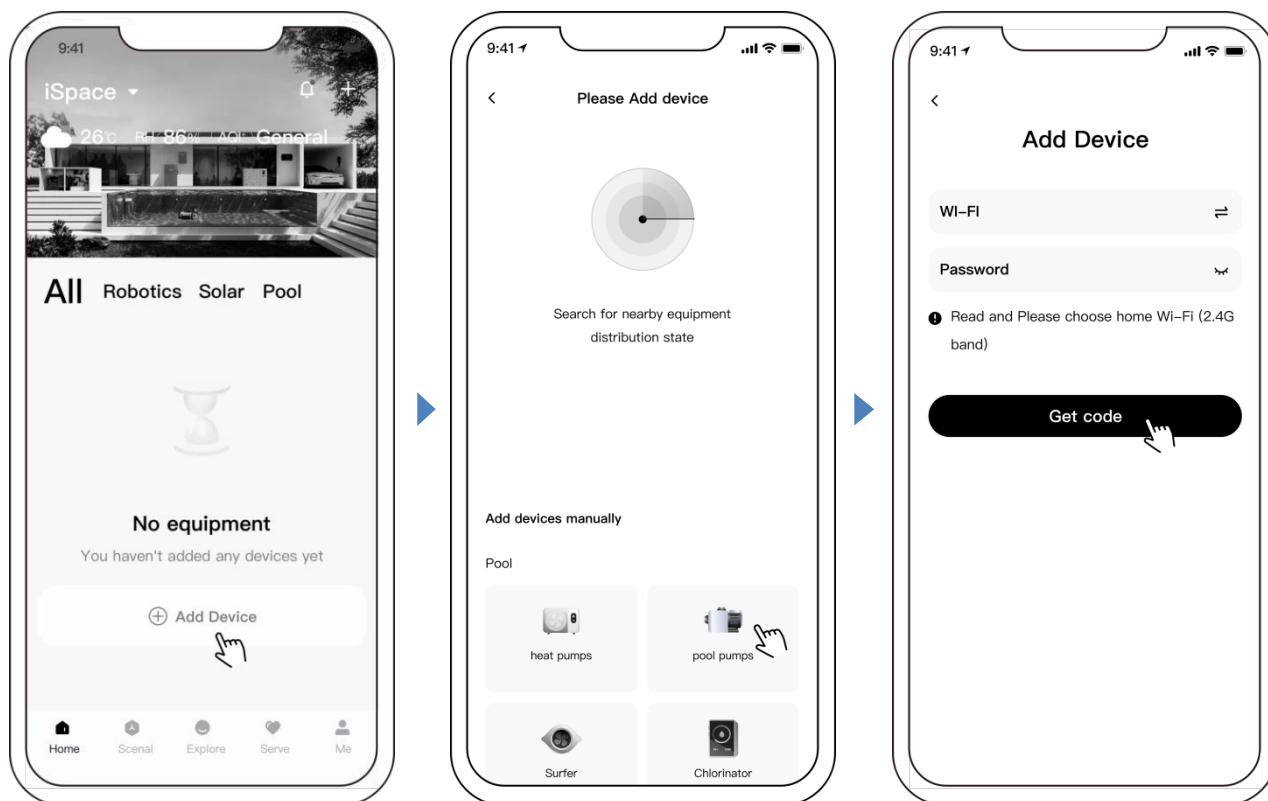

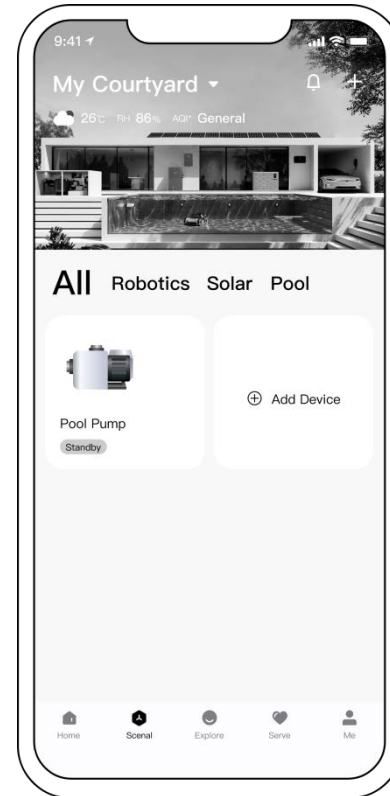
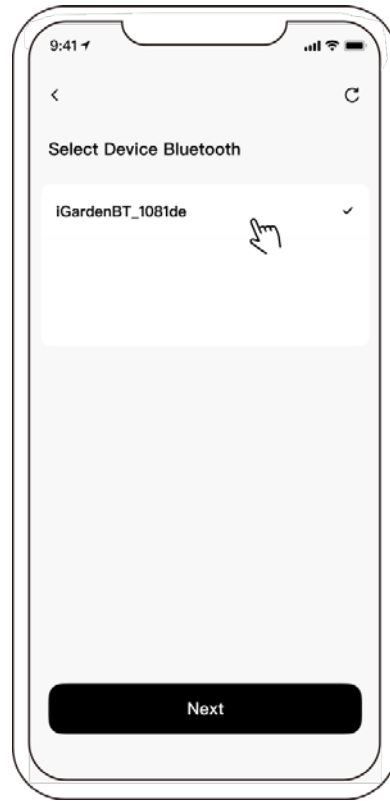
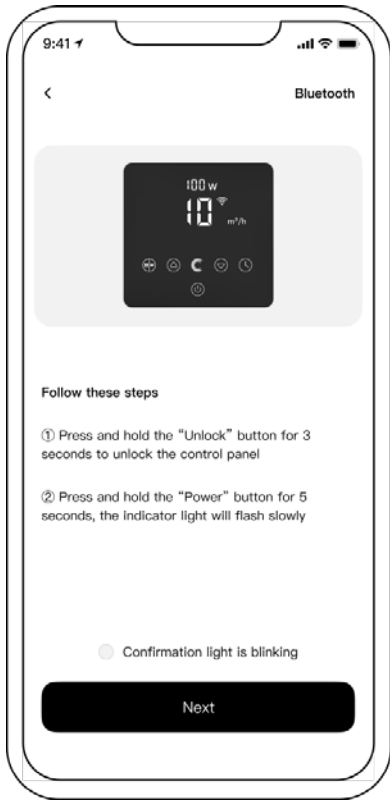

4 Opération

1) Mode inverseur automatique (mode AI):

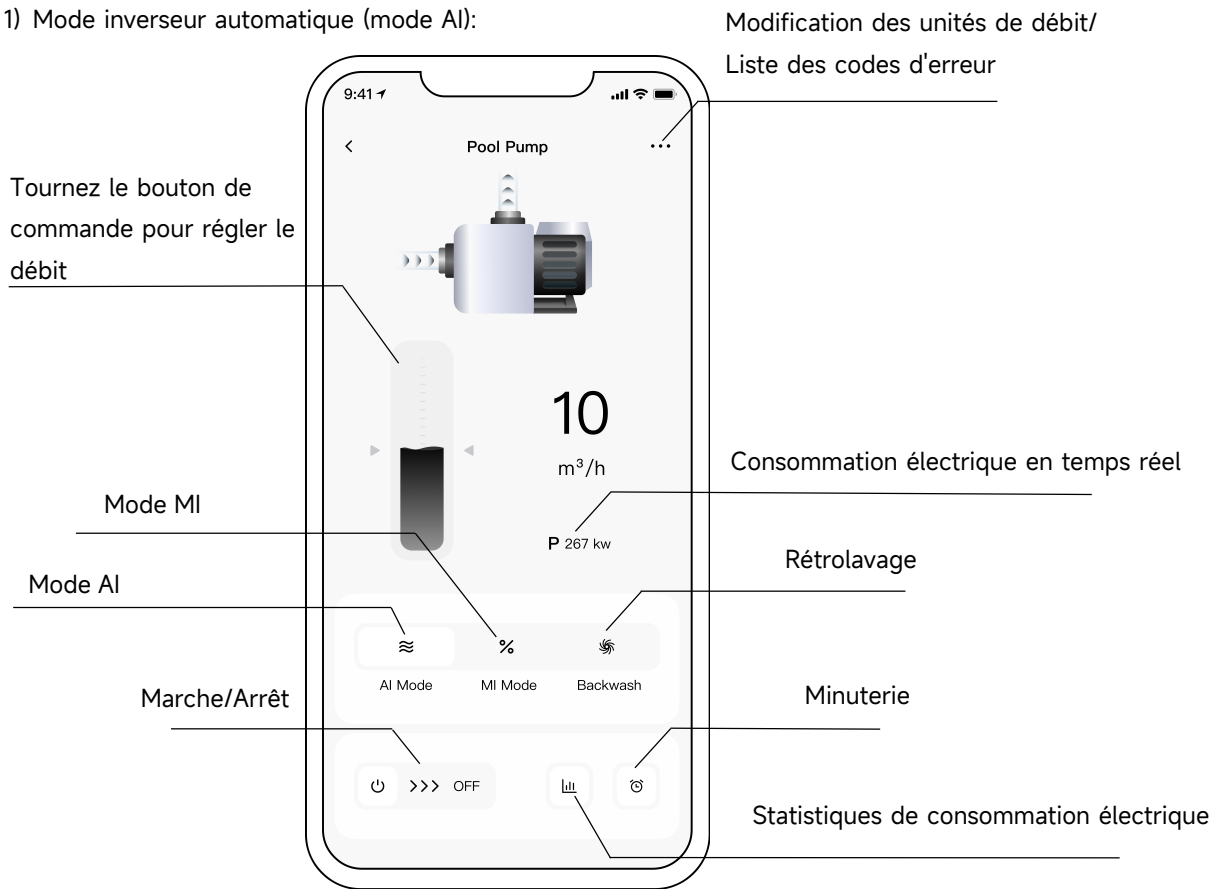

2) Mode inverseur manuel (mode MI)

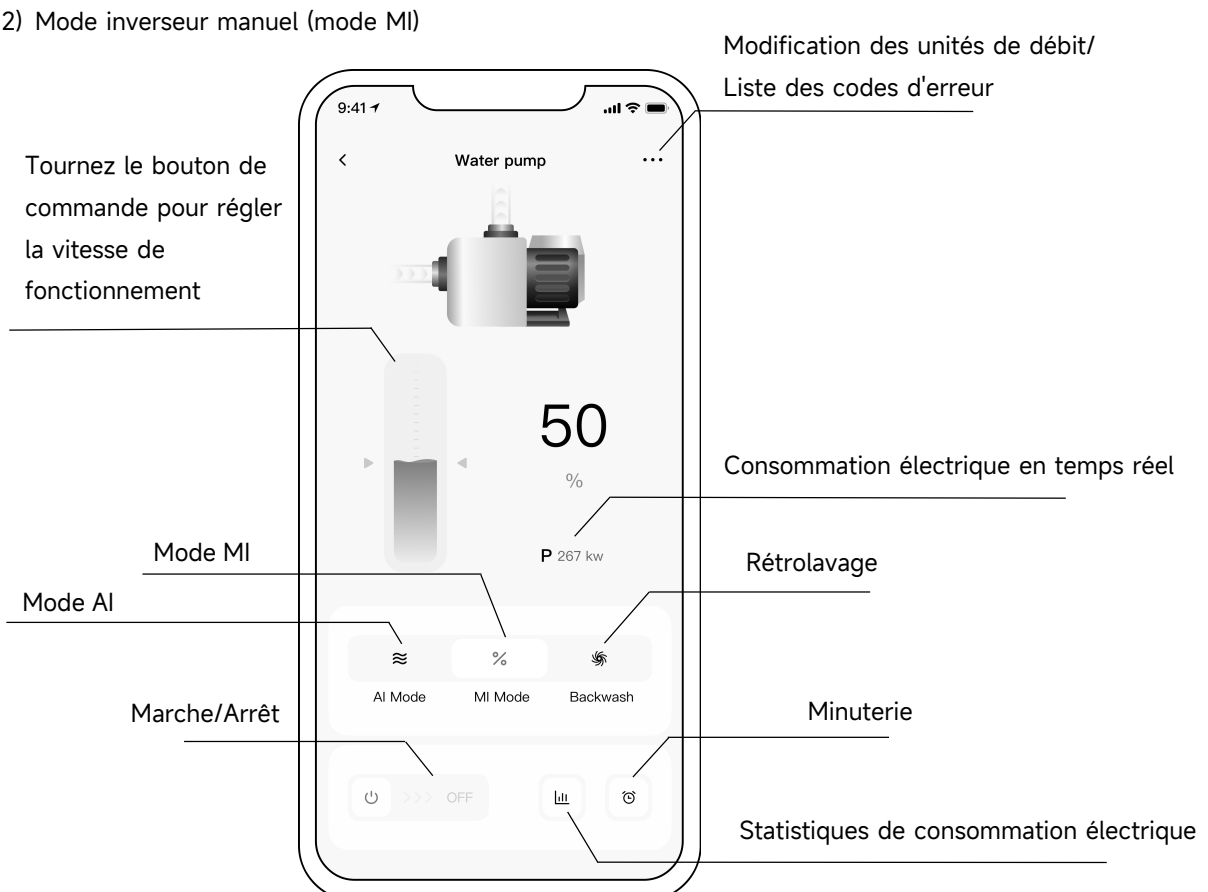

6) Mode de lavage à contre-courant :

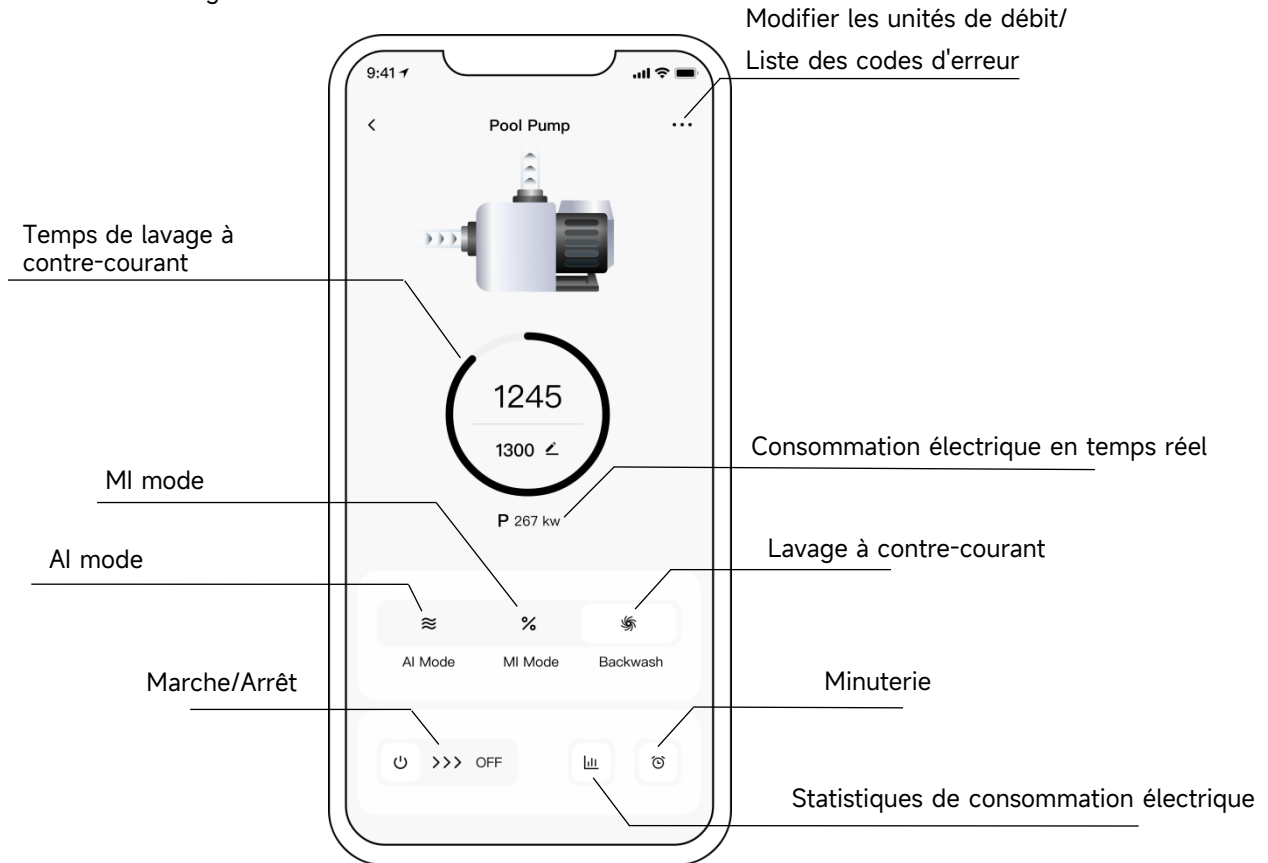

Remarque concernant le réglage de la minuterie via l'application :

- 1) La variance temporelle est de ± 30 s ;
- 2) Afin d'éviter que les points de synchronisation ne se chevauchent et ne soient invalidés en raison d'un délai réseau, il est recommandé que l'heure de fin et l'heure de début de la période de synchronisation suivante ne se chevauchent pas, et qu'un intervalle de temps suffisant soit réservé, par exemple, au moins 2 minutes ;

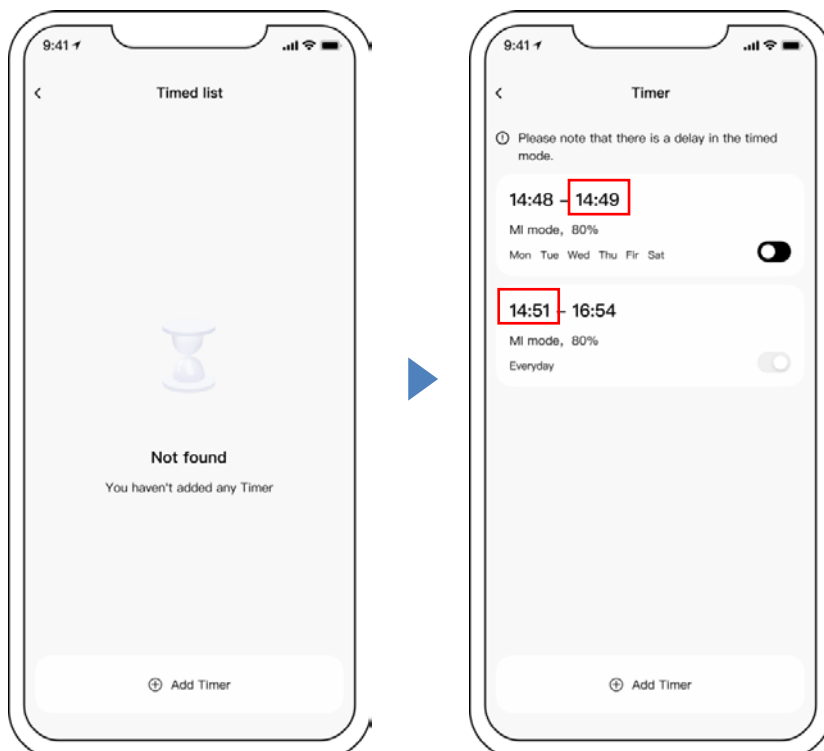

5 Partager des appareils avec les membres de votre famille

Les utilisateurs peuvent partager les appareils contrôlés par les membres de leur famille. Veuillez d'abord demander à vos proches de s'inscrire sur « iGarden », puis l'administrateur pourra procéder comme suit :

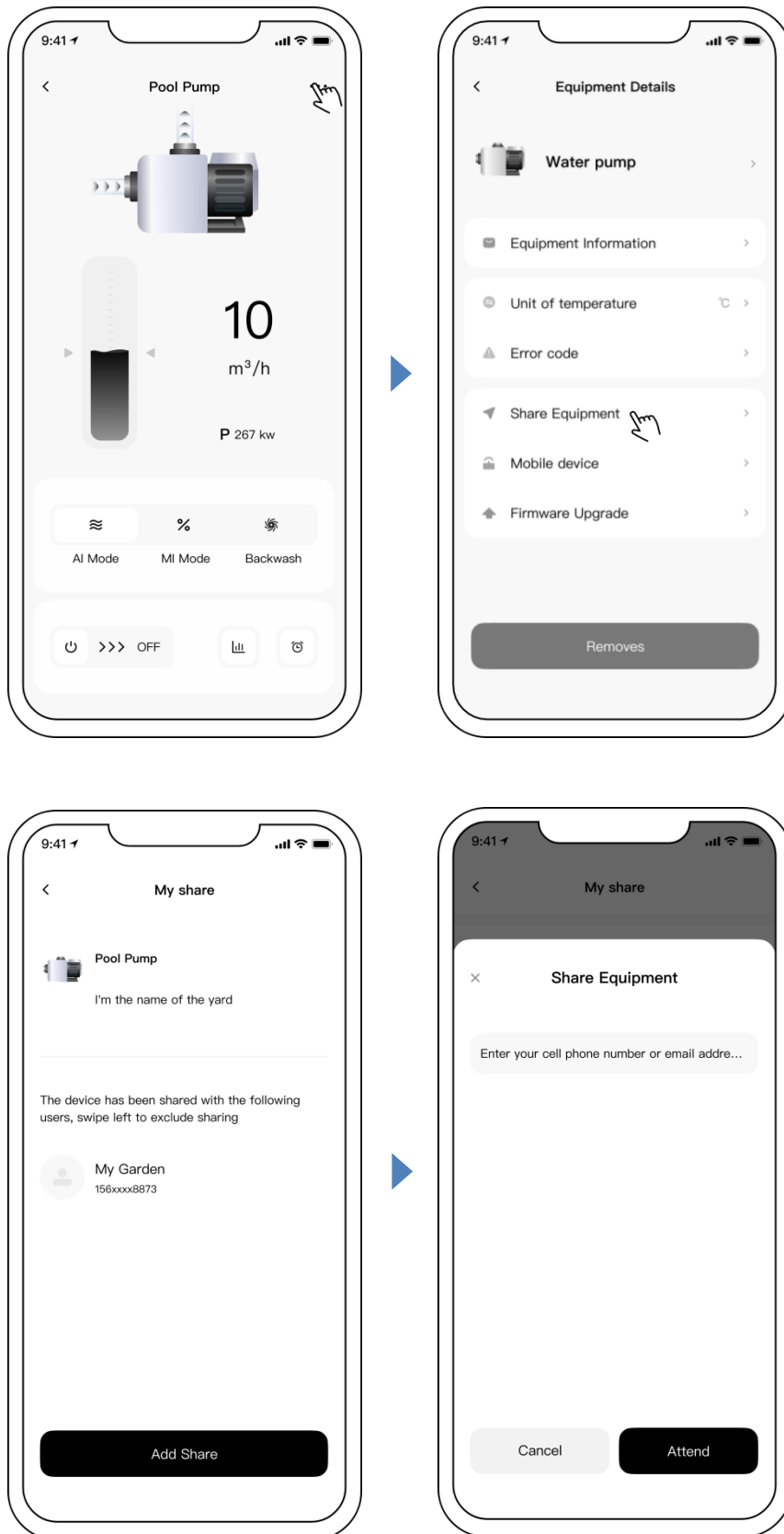

6 Gestion de jardin

Dans la liste des appareils, la cour actuelle est affichée. En cliquant dessus, les utilisateurs peuvent consulter/passé d'une cour à l'autre, cliquer sur « Gestion du jardin » et accéder à la page de la liste des cours. Voir ci-dessous :

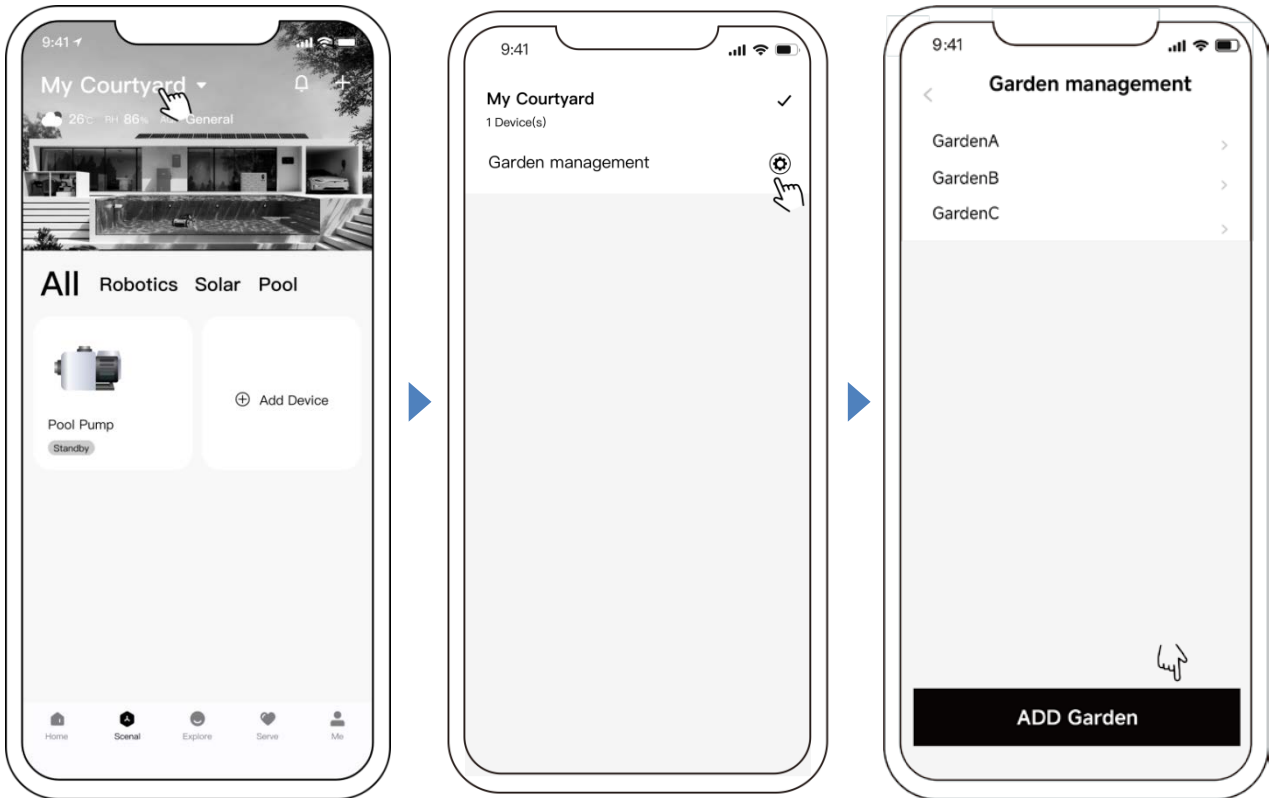

7 Centre de messagerie

A : Afficher le message : Sur la page de la liste des appareils, cliquez sur l'icône de message pour accéder au centre de messagerie et consulter le message correspondant, comme indiqué ci-dessous : (Y compris : Alarme, Jardin, Notification)

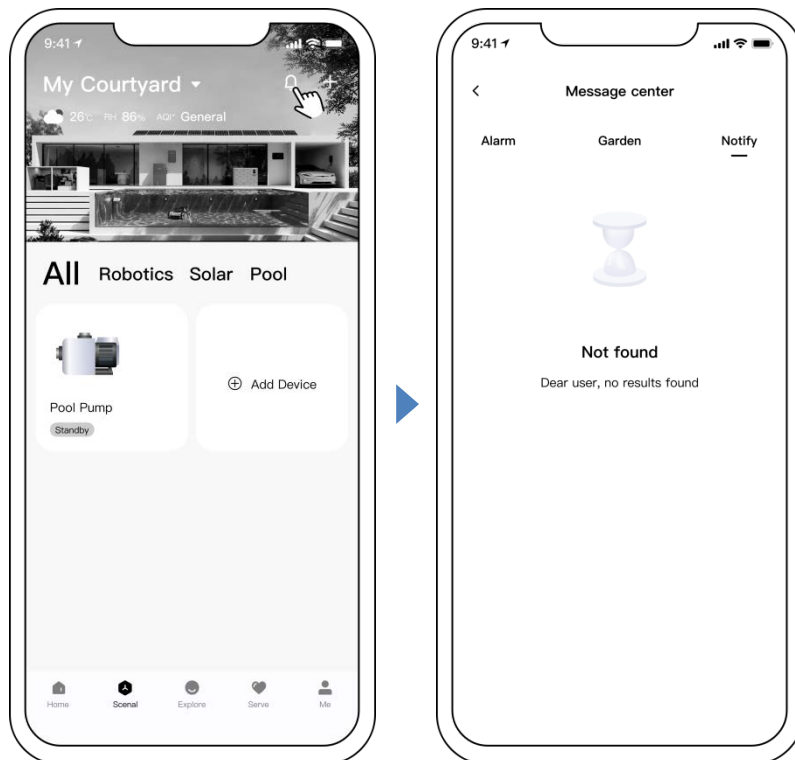

B : Paramètres des notifications push : Sur la page Paramètres, cliquez sur [Paramètres des notifications push] pour accéder à la page des paramètres des notifications push. Les utilisateurs peuvent configurer les paramètres des notifications push en fonction de la classification des messages, comme indiqué ci-dessous :

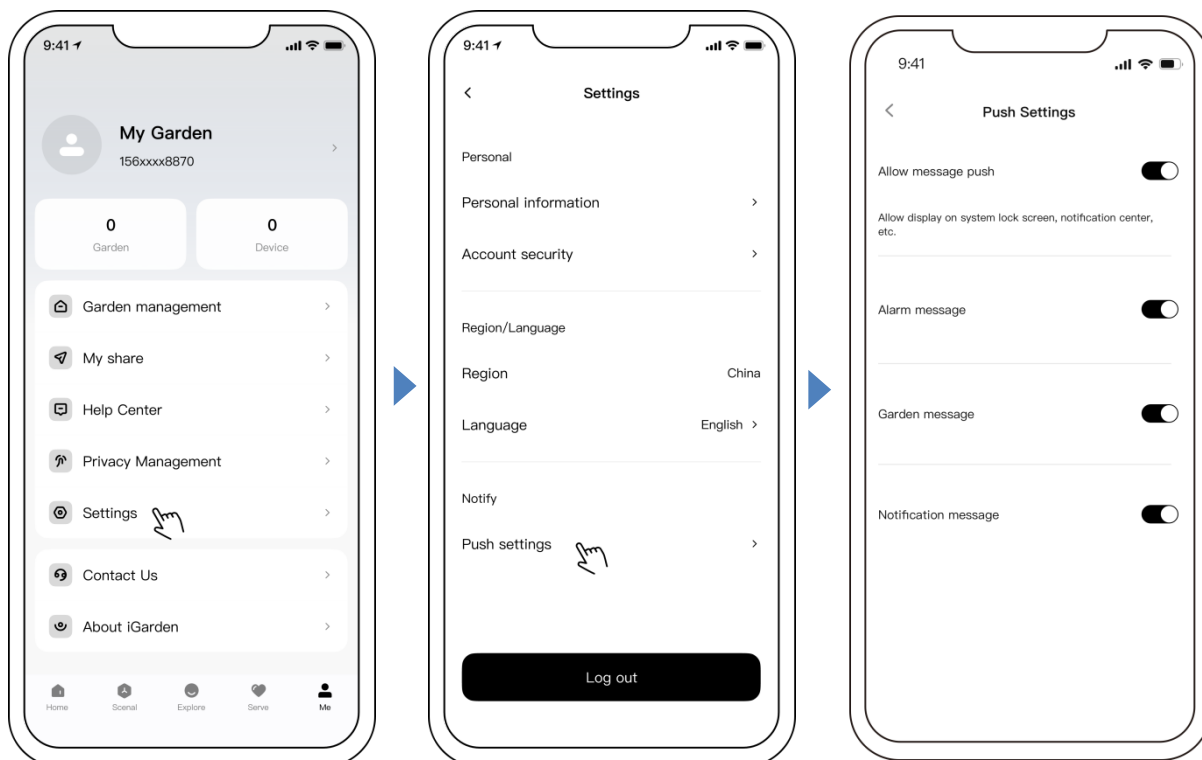

8 Retour

Si vous rencontrez le moindre problème lors de l'utilisation, n'hésitez pas à nous faire part de vos commentaires. La procédure est la suivante :

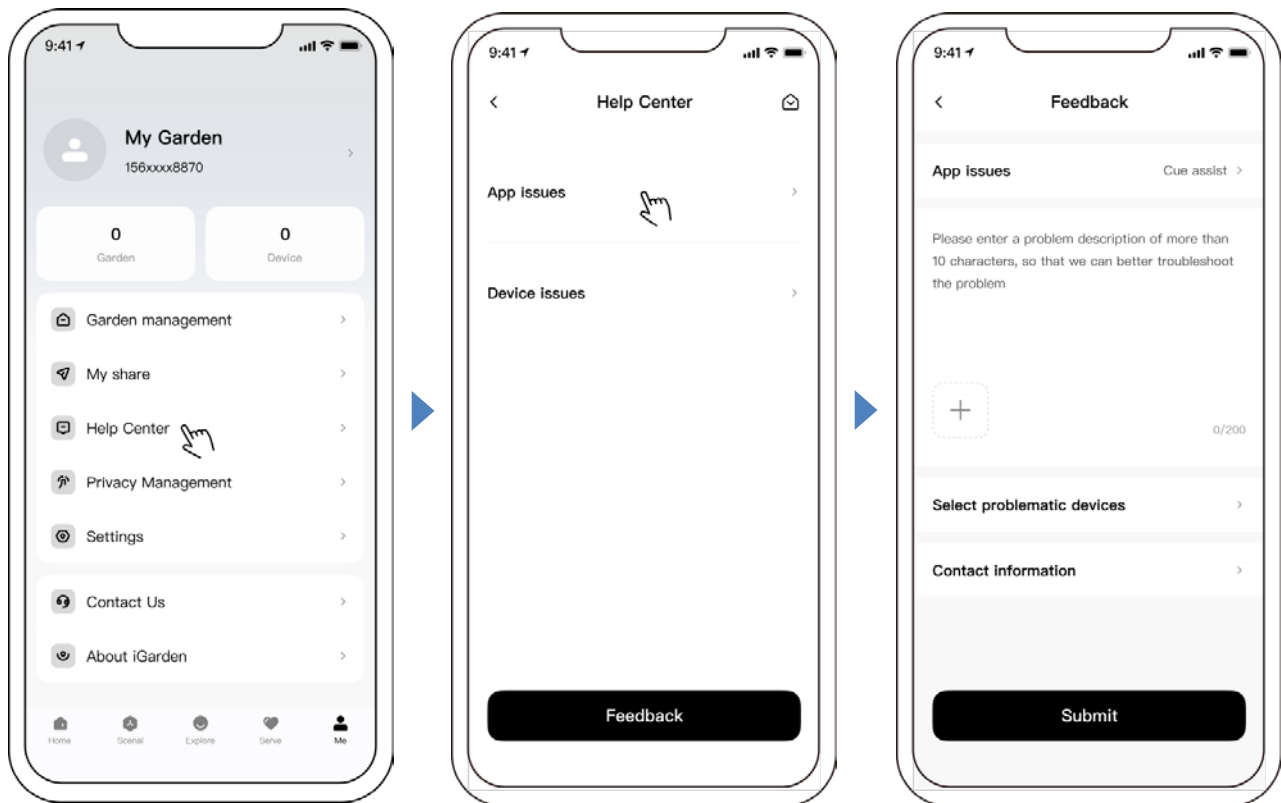

Avis:

- 1) Les prévisions météorologiques sont données à titre indicatif uniquement ;
- 2) Les données relatives à la consommation d'énergie ne sont données qu'à titre indicatif, car elles peuvent être affectées par des problèmes de réseau et par l'imprécision du calcul ;
- 3) L'application peut faire l'objet de mises à jour sans préavis.

7. CONTRÔLE EXTERNE

La commande externe peut être activée via les contacts suivants. Si plusieurs commandes externes sont activées, la priorité est la suivante : Entrée numérique > RS485 > Commande du panneau

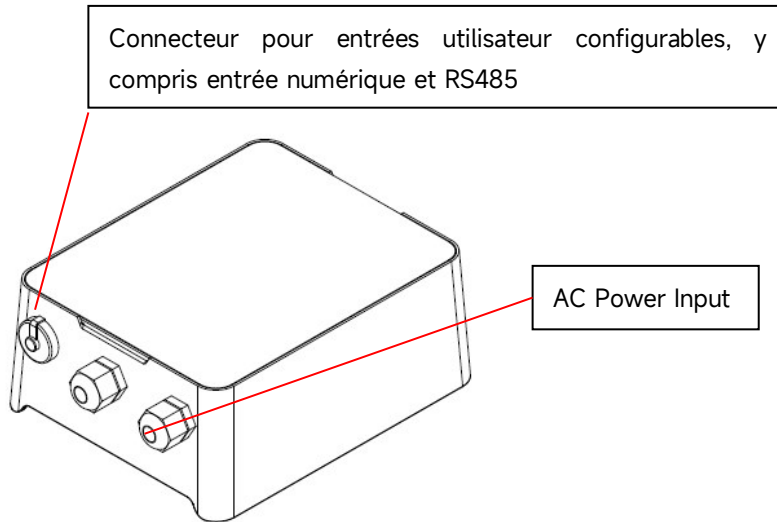

Figure 5 - Emplacement du port du connecteur

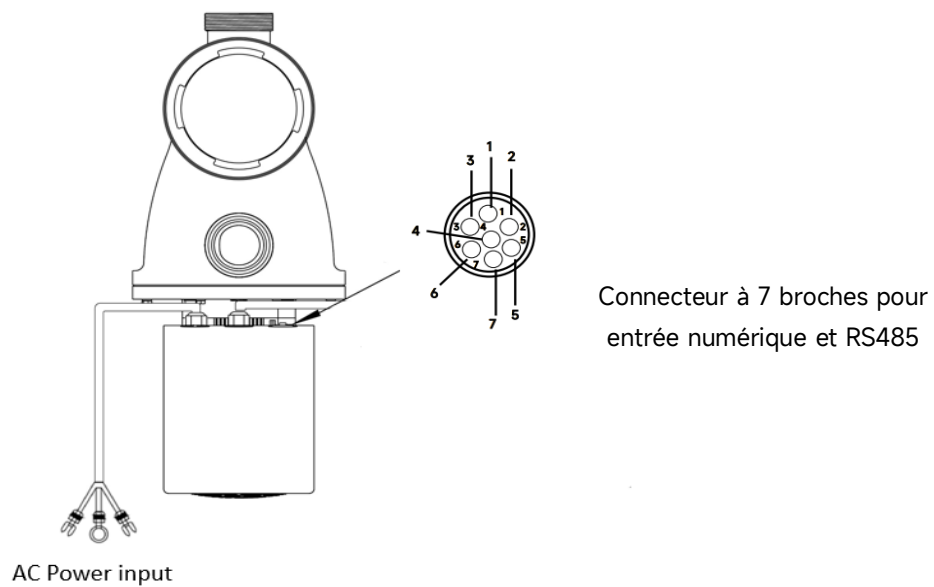

Figure 6 - Connecteur d'entrée numérique et RS485

Alimentation secteur (compatible 115 V et 230 V)

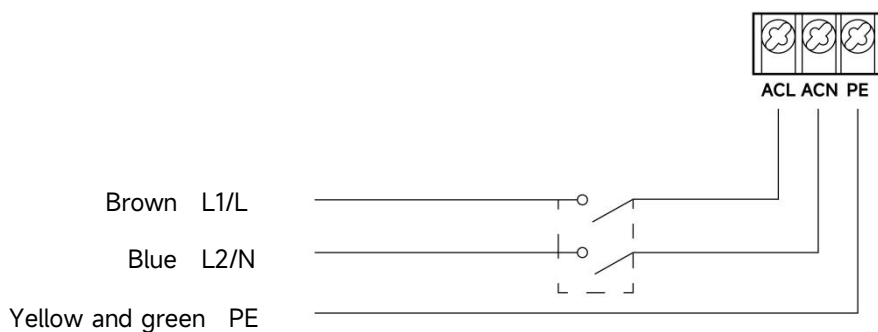

Figure 7 - Connexion du cordon d'alimentation

Contrôle externe	Couleur	Description	Note
Entrée numérique	Rouge	Di4 (Entrée numérique 4)	Vitesse par défaut = 40 %
	Noir	Di3 (Entrée numérique 3)	Vitesse par défaut = 80 %
	Blanc	Di2 (Entrée numérique 2)	Vitesse par défaut = 100 %
	Gris	Di1 (Entrée numérique 1)	Arrêt
	Jaune	Digital Ground (COM)	COM
RS485	Vert	RS485-A	/
	Brun	RS485-B	/

a. Entrée numérique

La capacité de fonctionnement est déterminée par l'état de l'entrée numérique.

- 1) Lorsque Di1 (gris) est connecté à COM (jaune), la pompe devra obligatoirement s'arrêter ; si elle est déconnectée, la commande numérique sera invalide ;
- 2) Lorsque Di2 (blanc) est connecté à COM (jaune), la pompe devra obligatoirement fonctionner à 100 % ; si elle est déconnectée, la priorité de contrôle reviendra au contrôle du panneau ;
- 3) Lorsque Di3 (noir) est connecté à COM (jaune), la pompe devra obligatoirement fonctionner à 80 % ; si elle est déconnectée, la priorité de contrôle reviendra au contrôle du panneau ;
- 4) Lorsque Di4 (rouge) est connecté à COM (jaune), la pompe devra obligatoirement fonctionner à 40 % ; si elle est déconnectée, la priorité de contrôle reviendra au contrôle du panneau ;
- 5) La capacité des entrées (Di2/Di3/Di4) peut être modifiée en fonction du paramétrage.

b. RS485

Pour se connecter avec RS485-A (vert) et RS485-B (marron), la pompe pourrait être contrôlée via le protocole de communication Modbus 485.

8. PROTECTION ET DÉFAILLANCE

8.1 de température élevée et réduction de vitesse - AL01

Dans "Auto Onduleur/Manuel En mode « Inverter » et en mode « Minuterie » (sauf en mode lavage à contre-courant/auto-amorçage), lorsque la température du module atteint le seuil de déclenchement de l'alerte de température élevée (81 °C), l'alerte est levée ; lorsqu'elle redescend au seuil de levée de l'alerte (78 °C), l' alerte est levée. L'écran affiche alternativement AL01 et la vitesse de fonctionnement ou le débit .

Si AL01 s'affiche , la capacité de fonctionnement sera automatiquement réduite comme suit :

- 1) Si la capacité opérationnelle actuelle est supérieure à 100 %, la capacité de fonctionnement sera automatiquement réduite à 85 % ;
- 2) Si la capacité opérationnelle actuelle se situe entre 85 % et 100 %, la capacité de fonctionnement sera automatiquement réduite de 15 % ;
- 3) Si la capacité opérationnelle actuelle se situe entre 70 % et 85 %, la capacité de fonctionnement sera automatiquement réduite de 10 % ;
- 4) Si la capacité opérationnelle actuelle est inférieure à 70 %, la capacité de fonctionnement sera automatiquement réduite de 5 %.

8.2 Protection contre les sous-tensions - AL02

L'appareil est compatible avec une entrée d'alimentation CA de 230 V et de 115 V.

① Alimentation secteur : 230 V

Lorsque l'appareil détecte une tension d'entrée inférieure à 198 V, il limite la vitesse de fonctionnement. L'écran affiche alternativement AL02 et la vitesse ou le débit.

- 1) Lorsque la tension d'entrée est inférieure ou égale à 180 V, la capacité de fonctionnement sera limitée à 70 % ;
- 2) Lorsque la plage de tension d'entrée se situe entre 180 V et 190 V, la capacité de fonctionnement sera limitée à 75 % ;
- 3) Lorsque la plage de tension d'entrée se situe entre 190 V et 198 V, la capacité de fonctionnement sera limitée à 85 % .

② Alimentation secteur : 115 V

Lorsque l'appareil détecte une tension d'entrée inférieure à 98 V, il limite la vitesse de fonctionnement. L'écran affiche alternativement AL02 et la vitesse ou le débit.

- 1) Lorsque la plage de tension d'entrée se situe entre 85 V et 90 V, la capacité de fonctionnement sera limitée à 75 % ;
- 2) Lorsque la plage de tension d'entrée se situe entre 90 V et 98 V, la capacité de fonctionnement sera limitée à 85 % .

Remarque : Si la tension d'entrée est inférieure à 85 V, le code d'erreur E001 (Tension d'entrée anormale, voir 8.4) sera affiché.

8.3 Dépannage

Problème	Causes possibles et solution
La pompe ne démarre pas.	<ul style="list-style-type: none"> • Panne d'alimentation, câblage déconnecté ou défectueux. • Fusibles grillés ou disjoncteur thermique ouvert. • Vérifiez que l'arbre moteur tourne librement et qu'il n'y a pas d'obstruction. • En raison d'une longue période d'inactivité, débranchez l'alimentation et faites tourner manuellement l'arbre arrière du moteur à plusieurs reprises à l'aide d'un tournevis.
La pompe ne s'amorce pas.	<ul style="list-style-type: none"> • Vidangez le boîtier de la pompe/du filtre. Assurez-vous que le boîtier de la pompe/du filtre est rempli d'eau et que le joint torique du couvercle est propre. • Connexions desserrées côté aspiration. • Panier de passoire ou panier d'écumoire rempli de débris. • Côté aspiration obstrué. • Si la distance entre l'entrée de la pompe et le niveau du liquide est supérieure à 2 m, la hauteur d'installation de la pompe doit être abaissée.
Débit d'eau faible	<ul style="list-style-type: none"> • La pompe ne s'amorce pas. • De l'air pénètre dans la tuyauterie d'aspiration. • Panier rempli de débris. • Niveau d'eau insuffisant dans la piscine.
La pompe est bruyante.	<ul style="list-style-type: none"> • Fuite d'air dans la tuyauterie d'aspiration, cavitation causée par une conduite d'aspiration restreinte ou sous-dimensionnée ou une fuite au niveau d'un joint, niveau d'eau bas dans la piscine et conduites de retour de refoulement non restreintes. • Vibrations dues à une installation incorrecte, etc. • Roulement ou turbine du moteur endommagés (il faut contacter le fournisseur pour réparation).

8.4 Code d'erreur

En cas de dysfonctionnement, l'appareil s'arrête automatiquement et affiche le code d'erreur . Après 15 secondes d'arrêt , vérifiez si le problème est résolu . Si le problème est résolu, la pompe reprendra son fonctionnement .

Article	Code d'erreur	Détails	
1	E001	Description	Tension d'entrée anormale : la tension d'alimentation est hors de la plage de 165V à 275V .
		Processus	La pompe s'arrêtera automatiquement pendant 15 secondes et

			reprendra son fonctionnement si elle détecte que la tension d'alimentation est dans la plage autorisée.
2	E002	Description	Surintensité de sortie : Le courant de crête de la pompe est supérieur au courant de protection.
		Processus	La pompe s'arrêtera automatiquement pendant 15 secondes, puis Reprenez le fonctionnement . Si cela se produit trois fois de suite, la pompe s'arrêtera et devra être vérifiée . redémarré manuellement.
3	E102	Description	Dissipateur de chaleur Erreur : La température du dissipateur thermique atteint 91 °C pendant 10 secondes . Ou le capteur du dissipateur thermique détecte un circuit ouvert ou un court-circuit .
		Processus	1. La pompe s'arrêtera automatiquement pendant 30 secondes et reprendra son fonctionnement si elle détecte que la température du dissipateur thermique est inférieure à 81 °C. 2. La pompe s'arrêtera automatiquement pendant 15 secondes. et reprendre le fonctionnement s'il détecte que le capteur du dissipateur thermique n'est pas en circuit ouvert ou en court-circuit .
4	E103	Description	de la carte mère : Le Carte de commande principale est défectueux.
		Processus	La pompe s'arrêtera automatiquement pendant 15 secondes, puis Reprenez le fonctionnement . Si cela se produit trois fois de suite, la pompe s'arrêtera et devra être vérifiée . redémarré manuellement.
5	E104	Description	Protection contre les défauts de phase : les câbles du moteur ne sont pas branchés sur la carte de commande principale .
		Processus	La pompe s'arrêtera automatiquement pendant 15 secondes, puis Reprenez le fonctionnement . Si cela se produit trois fois de suite, la pompe s'arrêtera et devra être vérifiée . redémarré manuellement.
6	E203	Description	de l'heure RTC : Lecture et écriture Les informations de l'horloge de minuterie sont incorrectes .
		Processus	Le la pompe doit être mis hors tension et redémarré manuellement.
7	E204	Description	Échec de lecture de l'EEPROM de la carte d' affichage : Lecture et écriture les informations de L' EEPROM du tableau d'affichage est incorrecte .
		Processus	Le la pompe doit être mis hors tension et redémarré manuellement.
8	E205	Description	Erreur de communication : La communication entre la carte d'affichage et la carte de commande principale échoue pendant 15 secondes.

		Processus	La pompe s'arrêtera automatiquement pendant 15 secondes. et reprendre le fonctionnement s'il détecte que la communication entre la carte d'affichage et la carte de commande principale dure 1 seconde.
9	E207	Description	Absence de protection contre l'eau : La pompe manque d'eau.
		Processus	Arrêtez la pompe manuellement, remplissez-la d'eau et redémarrez-la. Si cela se produit deux fois de suite, la pompe s'arrêtera et devra être vérifiée manuellement.
10	E209	Description	Perte d'amorçage : La pompe ne peut pas s'auto-amorcer pour des raisons telles que le dépassement de la plage d'aspiration ou une canalisation trop complexe.
		Processus	Vérifiez l'absence de fuite au niveau de la pompe ou de la canalisation, puis remplissez la pompe d'eau et redémarrez-la.

9. ENTRETIEN

Videz régulièrement le panier-filtre. Inspectez-le à travers le couvercle transparent et videz-le lorsqu'il est visiblement plein de déchets. Suivez les instructions suivantes :

- 1) J'ai débranché l'alimentation électrique.
- 2) Dévissez le couvercle du panier-filtre dans le sens inverse des aiguilles d'une montre et retirez-le.
- 3) Soulevez le panier-passoire.
- 4) Videz les déchets coincés dans le panier et rincez les débris si nécessaire.

Remarque : Ne pas cogner le panier en plastique contre une surface dure, car cela pourrait l'endommager.

- 5) Vérifiez si le panier présente des signes de dommages et remplacez-le.
- 6) Vérifiez que le joint torique du couvercle n'est pas étiré, déchiré, fissuré ou endommagé.
- 7) Remettez le couvercle en place, un serrage à la main suffit.

Remarque : Inspecter et nettoyer périodiquement le panier - filtre contribuera à prolonger sa durée de vie.

10. GARANTIE ET EXCLUSIONS

Si un défaut apparaît pendant la période de garantie, le fabricant réparera ou remplacera, à sa discrétion, l'article ou la pièce concerné(e) à ses frais. Les clients doivent suivre la procédure de réclamation au titre de la garantie afin de bénéficier de cette dernière.

La garantie sera annulée en cas d'installation incorrecte, de fonctionnement incorrect, d'utilisation inappropriée, de modification ou d'utilisation de pièces de rechange non d'origine.

11. ÉLIMINATION

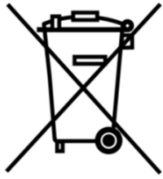

Lors de la mise au rebut du produit, veuillez trier les déchets comme déchets de produits électriques ou électroniques ou les remettre au système local de collecte des déchets.

Le tri et le recyclage des équipements usagés au moment de leur mise au rebut

 contribuent à garantir un recyclage respectueux de la santé humaine et de l'environnement. Contactez votre mairie pour connaître les points de collecte de votre pompe à eau en vue de son recyclage.

CONTENIDO

1. ⚠ INSTRUCCIONES DE SEGURIDAD IMPORTANTES	63
2. ESPECIFICACIONES TÉCNICAS	64
3. DIMENSIÓN TOTAL (mm)	64
4. INSTALACIÓN	65
5. AJUSTES Y FUNCIONAMIENTO	77
6. FUNCIONAMIENTO WIFI (OPCIONAL)	77
7. CONTROL EXTERNO	86
8. PROTECCIÓN Y FALLO	88
9. MANTENIMIENTO	91
10. GARANTÍA Y EXCLUSIONES	91
11. ELIMINACIÓN	92

GRACIAS POR ADQUIRIR NUESTRAS BOMBAS INVERTER PARA PISCINAS.

ESTE MANUAL CONTIENE INFORMACIÓN IMPORTANTE QUE LE AYUDARÁ A UTILIZAR Y MANTENER ESTE PRODUCTO.

LEA ATENTAMENTE EL MANUAL ANTES DE LA INSTALACIÓN Y EL FUNCIONAMIENTO, Y CONSERVÉLO PARA FUTURAS CONSULTAS..

1. INSTRUCCIONES DE SEGURIDAD IMPORTANTES

Al instalar y utilizar este equipo eléctrico, siempre se deben seguir las precauciones básicas de seguridad, incluidas las siguientes:

- 1) LEA Y SIGA TODAS LAS INSTRUCCIONES
- 2) ADVERTENCIA – Para reducir el riesgo de lesiones, no permita que los niños utilicen este producto a menos que estén bajo estricta supervisión en todo momento.
- 3) ADVERTENCIA: riesgo de descarga eléctrica. Conecte únicamente a un circuito derivado protegido por un dispositivo de corriente residual (RCD) con una corriente residual nominal que no supere los 30 mA. Póngase en contacto con un electricista cualificado si no puede verificar que el circuito está protegido por un dispositivo de corriente residual RCD.
- 4) PARA EVITAR EL RIESGO DE DESCARGA ELÉCTRICA, conecte el cable de tierra del motor (verde/amarillo) al sistema de puesta a tierra.
- 5) ADVERTENCIA – Para reducir el riesgo de descarga eléctrica, sustituya inmediatamente el cable dañado.
- 6) No instalar dentro de un recinto exterior ni debajo del faldón de una bañera de hidromasaje o spa.
- 7) Se debe instalar un seccionador en la instalación eléctrica fija de acuerdo con las normas de instalación.
- 8) Esta boma es para uso en piscinas, jacuzzis y spas.
- 9) PRECAUCIÓN: Para reducir el riesgo de descarga eléctrica, instale el dispositivo a una distancia mínima de 2 metros de las paredes interiores de la piscina. No utilice un cable de extensión.
- 10) PRECAUCIÓN: Para garantizar una protección continua contra el riesgo de descarga eléctrica, utilice únicamente piezas de repuesto originales .
- 11) Esta bomba está diseñada para usarse con piscinas enterradas o elevadas de instalación permanente y también puede utilizarse con jacuzzis y spas con una temperatura del agua inferior a 50 °C . Debido a su método de instalación fija, no se recomienda su uso en piscinas elevadas que se puedan desmontar fácilmente para su almacenamiento.
- 12) La bomba no es sumergible
- 13) Nunca abra el interior de la carcasa del motor de accionamiento
- 14) GUARDE ESTAS INSTRUCCIONES



ADVERTENCIA:

- Llene la bomba con agua antes de encenderla. No la haga funcionar en seco. Si funciona en seco, el sello mecánico se dañará y la bomba comenzará a gotear.
- Antes de realizar cualquier mantenimiento a la bomba, desconecte la alimentación eléctrica de la bomba desconectando el circuito principal y libere toda la presión de la bomba y del sistema de tuberías.
- Nunca apriete ni afloje los tornillos mientras la bomba esté en funcionamiento.
- Asegúrese de que la entrada y la salida de la bomba no estén obstruidas con materia extraña.

2. ECIFICACIONES TÉCNICAS

Modelo	Volumen de piscina recomendado (m ³)	P1	Voltaje (V/Hz)	Qmax (m ³ /h)	Hmax (m)	Circulación (m ³ /h)	
		KW				A 10 metros	A 8 metros
DCP12-IG	40-70	1.2	220-240/ 50/60	28.0	21.0	23.0	26.0

3. ENSIÓN TOTAL (mm)



Figura 1: Dimensiones de la bomba

4. INSTALACIÓN

4.1 Ubicación de la bomba

- 1) Instale la bomba lo más cerca posible de la piscina para reducir la pérdida por fricción y mejorar la eficiencia; utilice tuberías cortas y directas de succión y retorno.
- 2) Para evitar la luz solar directa, el calor o la lluvia, se recomienda colocar la bomba en el interior o a la sombra.
- 3) No instale la bomba en un lugar húmedo o sin ventilación. Mantenga la bomba y el motor a una distancia mínima de 150 mm de cualquier obstáculo; los motores de las bombas requieren una buena circulación de aire para su refrigeración.
- 4) La bomba debe instalarse horizontalmente y fijarse en el orificio del soporte con tornillos para evitar ruidos y vibraciones innecesarias.

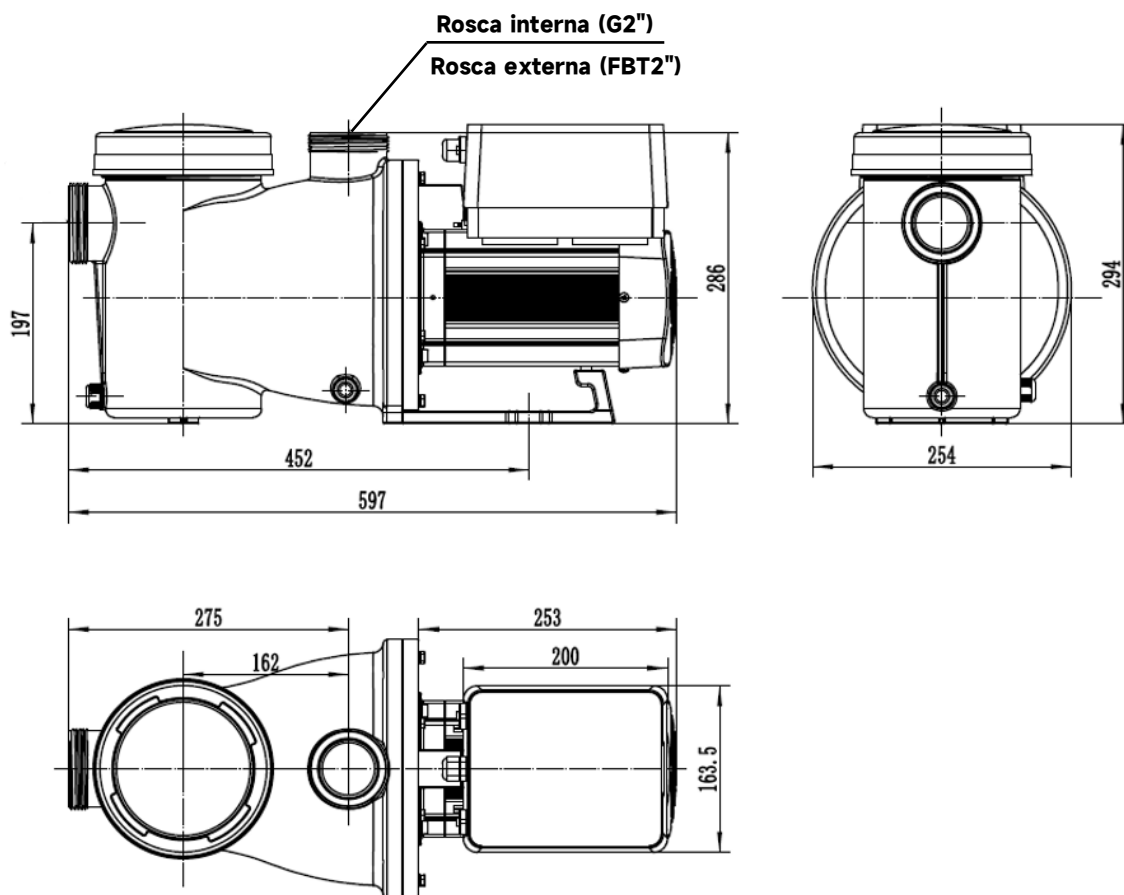
4.2 Fontanería y válvulas

- 1) Tamaño de la unión de entrada/salida de la bomba: opcional con sistema métrico (50 o 63 mm) o imperial (1,5 " o 2") .
- 2) Para optimizar la instalación de la piscina, se debe utilizar una tubería de mayor diámetro. Se recomienda utilizar una tubería de 63mm.
- 3) Al instalar los accesorios de entrada y salida (uniones) con la tubería, utilice el sellador especial para material de PVC.
- 4) La dimensión de la línea de succión debe ser igual o mayor que el diámetro de la línea de entrada, para evitar que la bomba aspire aire, lo que afectaría la eficiencia de la bomba.
- 5) Para reducir la pérdida por fricción y mejorar la eficiencia, las tuberías de succión y retorno deben ser cortas y directas.
- 6) Los sistemas de succión inundados deben contar con válvulas instaladas tanto en la línea de succión como en la de retorno de la bomba, lo cual facilita el mantenimiento rutinario. Una válvula, codo o T instalada en la línea de succión no debe estar a una distancia menor a siete veces el diámetro de la línea de succión de la entrada de la bomba.
- 7) Utilice una válvula de retención en la línea de retorno donde exista una altura significativa entre la línea de retorno y la salida de la bomba, para evitar que la bomba se vea afectada por la recirculación del fluido y el golpe de ariete que provoca la parada de la bomba .

4.3 Guarniciones

- 1) Los codos deben estar a una distancia mínima de 350 mm de la entrada. No instale codos de 90° directamente en la entrada/salida de la bomba. Las juntas deben quedar bien ajustadas.
- 2) Las juntas deben estar bien ajustadas.



Figura 2 - Instalaciones de fontanería y accesorios

* Tamaño de la unión de entrada/salida de la bomba: opcional en sistema métrico (50 o 63 mm) o imperial (1,5 " o 2").

- 3) Utilice el KIT DE UNIÓN suministrado por el fabricante de la bomba (consulte la figura 3). No utilice otros racores para conectar la entrada/salida de la bomba, ya que podrían no ser compatibles y dañar el cuerpo de la bomba.

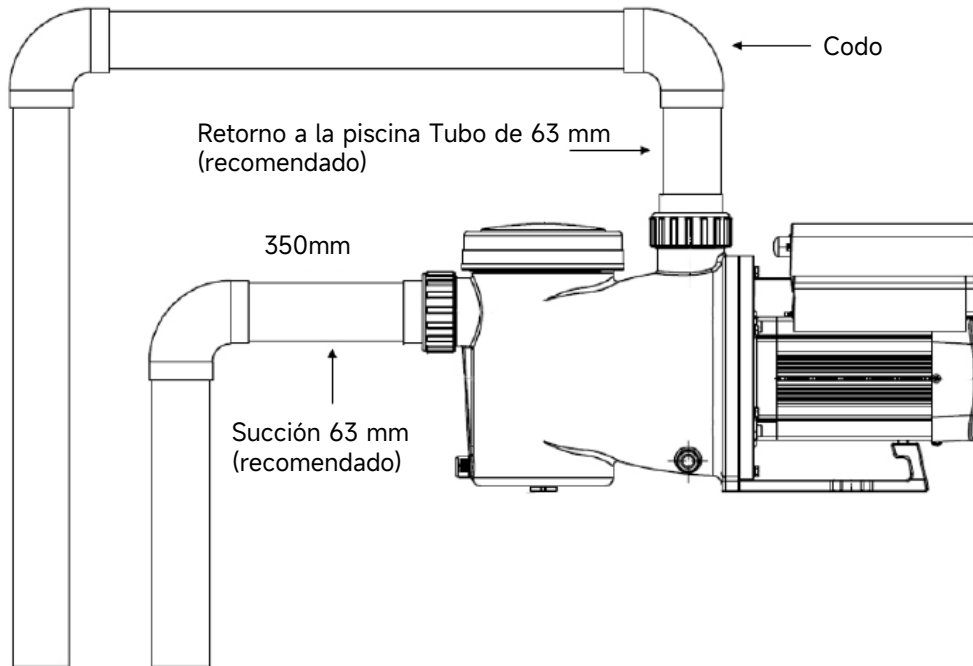

Figura 3 - Kit de unión

4.4 Comprobar antes del inicio inicial

- 1) Comprobar si el eje de la bomba gira libremente;
- 2) Compruebe que la tensión y la frecuencia de la fuente de alimentación se ajustan a las indicadas en la placa de características;
- 3) Mirando hacia la aspa del ventilador, el sentido de giro del motor debe ser en el sentido de las agujas del reloj;
- 4) Está prohibido hacer funcionar la bomba sin agua.

4.5 Condiciones de aplicación

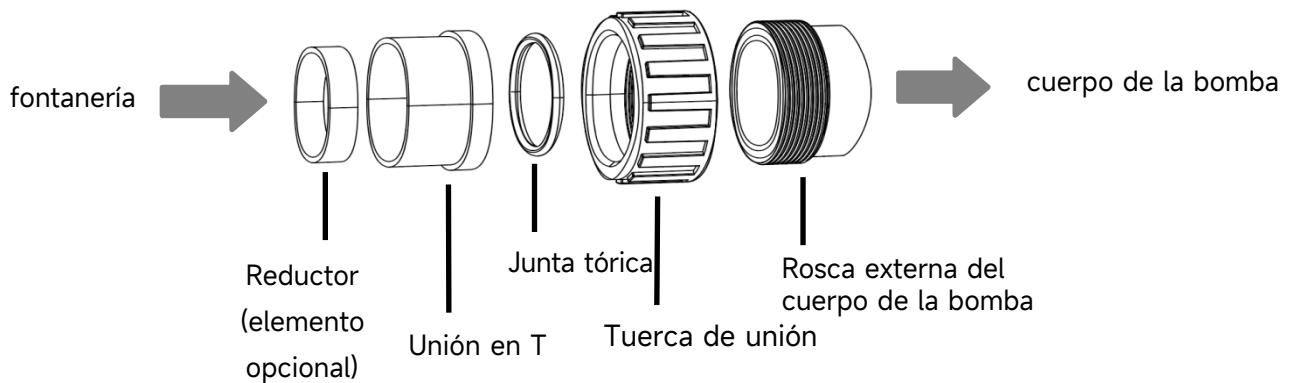
Temperatura ambiente	Instalación en interiores, rango de temperatura: -10-42°C
Temperatura máxima del agua	50°C
Agua salada disponible	Concentración de sal hasta el 3,5%, es decir, 35 g/l
Humedad	≤90% HR, (20°C±2°C)
Instalación	La bomba se puede instalar a un máximo de 2 m por encima del nivel del agua.
Protección	Clase F, IP55

5. CONFIGURACIÓN Y FUNCIONAMIENTO



5.1 Pantalla en el panel de control

	① consumo de energía
	② Capacidad de funcionamiento / Caudal
	③ Indicador WIFI (elemento opcional)
	④ Unidad de flujo
	⑤ período del temporizador
	⑥ Temporizador 1/2/3/4
	Retrolavado/desbloqueo
	Arriba/abajo: para cambiar el valor del ajuste
	Cambiar entre Manual Modo inversor y Auto Modo Inversor
	<p>Manual Modo inversor : La capacidad de funcionamiento se ajustará manualmente entre el 30% y el 120 %.</p> <p>Auto Modo inversor : La capacidad de funcionamiento se ajustará automáticamente entre el 30% y el 120 % según el caudal preestablecido.</p> <p>El modo predeterminado es Manual Inversor modo.</p>
Configuración del temporizador	
Encendido/apagado	

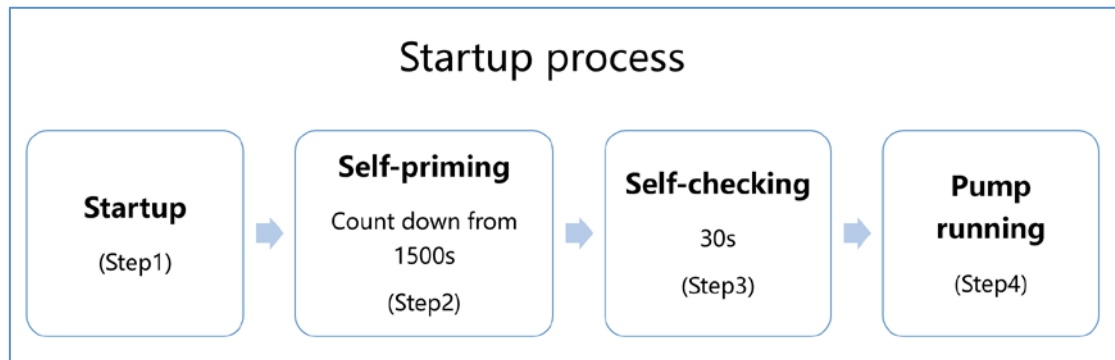
5.2 Puesta en marcha proceso descripción general



① Paso 1 : Inicio

- Mantén pulsado  durante más de 3 segundos para desbloquear la pantalla .
- Prensas  a puesta en marcha el bomba.

Paso 2 : Autoaprendizaje

- El bomba comenzará Cuenta regresiva desde 1500 segundos ; cuando el sistema detecte que la bomba está llena de agua, detendrá la cuenta regresiva y saldrá del cebado automáticamente.
- Los usuarios pueden ingresar la configuración del parámetro para deshabilitar la función de autocebado predeterminada (ver 5.11) .



③ Paso 3 : Autocomprobación

- El bomba Volveremos a comprobar durante 30 segundos para asegurarnos de que se ha completado el autocebado (Paso 2) .

④ Paso 4 : Bomba correr

- La bomba funcionará al 80% de su capacidad de funcionamiento en el arranque inicial después del autocebado.

5.3 Puesta en marcha

Cuando se encienda la alimentación, la pantalla se iluminará completamente durante 3 segundos, se mostrará el código del dispositivo y, a continuación, entrará en su estado de funcionamiento normal. Cuando la pantalla esté bloqueada, solo se mostrará el código del dispositivo. botón  Se iluminará; mantenga pulsado  durante más de 3 segundos para desbloquear la pantalla. La pantalla se bloqueará automáticamente si no se realiza ninguna operación durante más de 1 minuto y su brillo se reducirá a 1/3 del brillo normal. Pulse brevemente  para activar la pantalla y consultar los parámetros de funcionamiento relevantes.

5.4 Autocebado

que se ponga en marcha la bomba, comenzará a autocebarse.

Cuando la bomba funciona Autocebante, comenzará la cuenta regresiva. A partir de 1500 segundos, el sistema detendrá la cuenta regresiva automáticamente cuando detecte que la bomba está llena de agua; luego, el sistema volverá a verificar durante 30 segundos para asegurarse de que se haya completado el autocebado.

El usuario puede cancelar el autocebado manualmente pulsando  durante más de 3 segundos. La bomba entrará en el modo de inversor manual predeterminado al arrancar inicialmente.



Observación:

la función de autocebado activada. Cada vez que se reinicie, realizará el autocebado automáticamente.

Los usuarios pueden acceder a la configuración de parámetros para desactivar la función de autocebado predeterminada (véase 5.11).

5.5 Resaca











El usuario puede iniciar el retrolavado o la recirculación rápida en cualquier estado de funcionamiento pulsando .

	Por defecto	Rango de ajuste
Tiempo	década de 180	Pulse  o  para ajustar de 0 a 1500 s con 30 segundos por cada paso.
capacidad de funcionamiento	100%	60-100%, introduzca el valor del parámetro (véase 5.11)

de salida :

Cuando el modo de retrolavado está activado, los usuarios pueden mantener pulsado el botón  durante 3 segundos para cancelarlo; la bomba volverá al estado anterior al retrolavado. Si los usuarios han establecido un límite de velocidad, la capacidad de funcionamiento del retrolavado no superará dicho límite. (Véase 5.10)

5.6 Manual Modo inversor

1		Mantén pulsado  durante más de 3 segundos para desbloquear la pantalla .
2		Pulse  para iniciar. La bomba funcionará al 80% de su capacidad de funcionamiento en el arranque inicial después del autocebado.
3	 	Presione  o  para ajustar la capacidad de funcionamiento entre el 30% y el 120%, en incrementos del 5% .
4		Pulse  de nuevo para cambiar al modo Inversor automático.

Nota :







- 1) Cuando la presión en la tubería es alta, para mantener un caudal adecuado, el usuario puede ajustar la capacidad de funcionamiento entre el 105 % y el 120 %. La bomba funcionará a mayor velocidad para contrarrestar la alta presión en la tubería.
- 2) En el rango de 105%~120% de capacidad de funcionamiento, la bomba ajustará automáticamente la velocidad cuando alcance la potencia máxima.

Por ejemplo, cuando el usuario ajusta la velocidad al 110 %, si la bomba La potencia ha alcanzado su valor máximo a esta velocidad . En este momento, incluso si el usuario continúa aumentando la velocidad de la bomba al 120% , la bomba mantendrá la velocidad a la máxima potencia, es decir, al 110 %. Y la velocidad mostrada disminuirá del 120% al 110%.

5.7 Auto Modo inversor

En el modo de inversor automático, la bomba puede detectar automáticamente la presión del sistema y ajustar la velocidad del motor para alcanzar el caudal establecido.

1		Desbloquea la pantalla y pulsa  para cambiar del modo Inversor Manual al modo Inversor Automático.
2	 	El caudal se puede ajustar presionando  o  con 1 m ³ /h por cada paso.

3	 	La unidad de caudal se puede cambiar a L /min , IMP gpm o US gpm pulsando ambos botones.   durante 3 segundos .
4		Pulse  para cambiar al modo inversor manual .

El rango de flujo ajustable predeterminado para InverK es el siguiente :

Modelo	de caudal ajustable *
DCP12-IG	8-25 m ³ /h

*** Nota :**











En el modo inversor automático, el caudal máximo ajustable se basa en una altura de elevación de aproximadamente 8 m.

Si los usuarios configuran el caudal al valor máximo ajustable y la presión de la tubería es superior a 8 m, en esta situación la bomba aumentará automáticamente la velocidad de funcionamiento y la potencia de entrada para contrarrestar la alta presión y mantener el caudal máximo que hayan configurado los usuarios.

Cuando la velocidad del motor y la potencia de entrada aumentan hasta el nivel máximo, pero no es suficiente para contrarrestar la enorme presión de la tubería, el caudal mostrado en el controlador de la bomba disminuirá desde el caudal establecido hasta el caudal real alcanzable .

5.8 Modo temporizador

La capacidad de encendido/apagado y funcionamiento de la bomba podría controlarse mediante un Temporizador, que podría programarse diariamente según fuera necesario.

1	Introduzca la configuración del temporizador pulsando 
2	Pulse  o  para ajustar la hora local
3	Pulse  para confirmar y pasar a la configuración de tiempo 1.
4	Prensa  o  para elegir los períodos de funcionamiento , la capacidad de funcionamiento o el caudal deseados . (Cuando el icono % parpadea, los usuarios pueden cambiar el ajuste del caudal pulsando )
5	 Repita los pasos anteriores para configurar el otros 3 temporizadores
6	 Mantén pulsado durante 3 segundos para guardar la configuración y activar el modo temporizador.
7	 o  Comprueba 4 temporizadores para asegurarte de que no haya ninguna configuración no válida.

Nota:

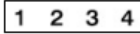
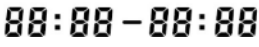

1) Si el período de tiempo establecido incluye la hora actual, la bomba comenzará a funcionar según la capacidad de funcionamiento o el caudal configurados , como indica el indicador del temporizador .

 (1, 2, 3 o 4) se iluminarán, y el área  Mostrará el período de tiempo correspondiente .

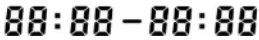
2) Si el período de tiempo establecido no contiene la hora actual, el número del temporizador

 (1, 2, 3 o 4) que está a punto de comenzar a ejecutarse se mostrará y parpadeará , y el área  Mostrará el período de tiempo correspondiente .

3) Durante la configuración del temporizador, si desea volver a la configuración anterior, mantenga

pulsados ambos botones   durante 3 segundos. Si no necesita configurar los 4 temporizadores, puede mantener pulsado  durante 3 segundos; el sistema guardará automáticamente el valor configurado y activará el modo temporizador.



4) Se han limitado los ajustes del temporizador de la bomba ; los usuarios no configurarán temporizadores superpuestos.



5) Una vez configurado el temporizador y apagado la bomba por parte del usuario, al volver a encenderla, el temporizador regresará al modo programado.

6) Los usuarios pueden cancelar el modo temporizador pulsando .

5.9 Desnatadora Modo

El modo skimmer permite que la bomba recoja la superficie del agua, evitando la acumulación de residuos y proporcionando a los usuarios una piscina más limpia.

Mantenga pulsado  para  acceder a la interfaz predefinida del modo skimmer. Al activar este modo por primera vez, se activará la configuración predefinida 1.

Los usuarios pueden pulsar  para  ver los 4 preajustes; los detalles de cada preajuste se muestran a continuación. El preajuste seleccionado se activará después de 5 segundos sin ninguna operación.

Preinicio	Ciclo del skimmer	Duración del Skimmer	Velocidad de skimmer	período de tiempo	Observación
1	1 hora	3 minutos	100%	7:00 – 21:00	Editable en configuración de parámetros
2	1 hora	10 minutos	100 %	7:00 – 21:00	No editable
3	3 horas	3 minutos	80 %	7:00 – 21:00	No editable
4	Desactive el modo skimmer				No editable

Tabla 1: Ajustes preestablecidos del modo

Durante la duración del skimmer, el controlador mostrará el parámetro preestablecido que el usuario

puede mantener.  Mantenga presionado durante 3 segundos para cancelar la duración del skimmer cada vez. Cuando finalice la duración del skimmer, la bomba volverá a su estado normal para que el usuario pueda operarla.

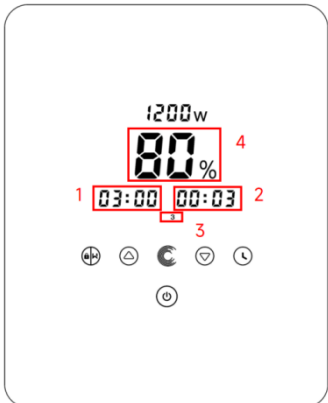
	<ol style="list-style-type: none"> 1. skimmer (hora) 2. del Skimmer (minutos) 3. Número preestablecido del modo Skimmer 4. Velocidad del skimmer / caudal
--	---



Figura 4 - Ciclo del skimmer

5.10 Límite de velocidad /caudal

Los usuarios pueden configurar el límite de velocidad /caudal de la bomba para cumplir con los requisitos de caudal de otros equipos, como los filtros de arena.



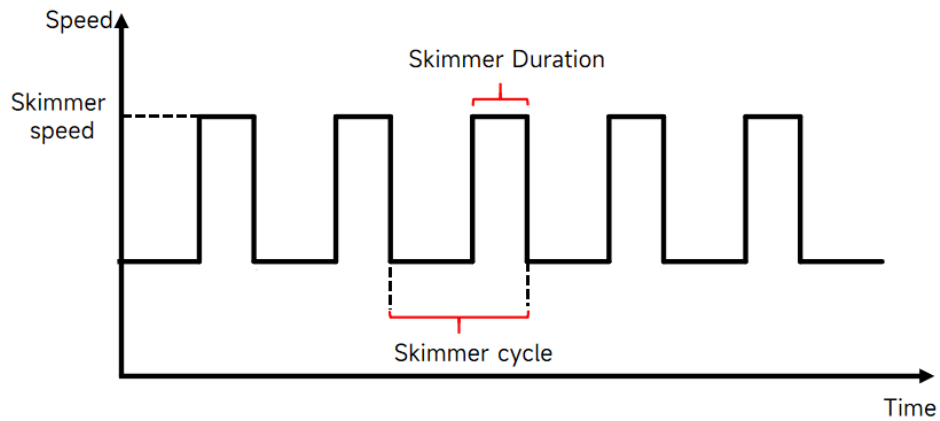



El límite de velocidad /caudal de la bomba se puede configurar en los ajustes de parámetros. (ver 5.1.1)



100% significa que no hay límite de velocidad y la capacidad de funcionamiento se puede configurar entre el 30% y el 120% en condiciones normales de funcionamiento.



Modelo	Límite de velocidad/caudal	
	Velocidad máxima de funcionamiento	Caudal máximo
DCP12-IG	60%-100%	15-25 m ³ /h



Para garantizar el rendimiento, se realiza un proceso de autocebado en cada inicio. No estará limitado por la función de límite de velocidad /caudal .

5.11 Configuración de parámetros





Restaurar configuración de fábrica	Apague la bomba y luego sostenga ambos   durante 3 segundos
Compruebe la versión del software	Apague la bomba y luego sostenga ambos   durante 3 segundos
Introduzca la configuración de parámetros como se indica a continuación	Apague la bomba y luego sostenga ambos   durante 3 segundos;

	 Para seleccionar la dirección del parámetro, pulse  o  para ajustar la configuración del parámetro.
--	--

Parámetro DIRECCIÓN	Descripción	Configuración predeterminada	Rango de ajuste
1	Di2 (Entrada digital 2)	Velocidad: 100%	Velocidad: 30-120%, en incrementos del 5% ;
2	Di3 (Entrada digital 3)	Velocidad: 80 %	Caudal: 1 m ³ /h s estadounidenses por minuto incrementos; DCP12-IG: 8-25 m ³ /h
3	Di4 (Entrada digital 4)	Velocidad: 40 %	Nota : Prensa  a cambiar a flujo tasa configuración .
4	Resaca	Velocidad: 100%	Velocidad: 60-100% , en incrementos del 5%; Caudal:1 m ³ /h incrementos; DCP12-IG: 8-25 m ³ /h Nota : Prensa  a cambiar a flujo tasa configuración.
5	Modo de control de entrada analógica	0	0: Control de corriente 1: Control de voltaje
6	Habilite o deshabilite el autocebante en cada inicio.	25	25: habilita 0: desactiva
7	Reservado	0	No editable
8	Tiempo del sistema	00:00	00:00 - 23:59

9	Preiniciar 1 del modo skimmer	Ciclo de Skimmer: 0 1:00 Skimmer : 00:03 Velocidad de deslizamiento S : 100%	*Ciclo de Skimmer : 1 - 24 h, 1 h por cada paso ; * Duración del batidor: 1 - 30 min, 1 min por cada paso ; * Velocidad del skimmer: 30%-100%, en incrementos del 5%; * Caudal del skimmer: 1 m ³ /h incrementos; DCP12-IG: 8-25 m ³ /h Nota : Prensa  a cambiar a flujo tasa configuración.
10	Periodo de tiempo del preajuste 1 del modo skimmer	7:00 - 21:00	Horario de inicio: 00:00 - 24:00 Hora de finalización: 00:00-24:00
11	Límite de velocidad	Velocidad: 100%	Velocidad : 60 %-100%, en incrementos del 5%; (100% significa sin límite de velocidad) Caudal : 1 m ³ /h incrementos; DCP12-IG: 15-25 m ³ /h Nota : Prensa  a cambiar a flujo tasa configuración .
12	RS485	170(0xAA)	160-190 (0xA0-0xBF), cada paso de 1.
13	Reservado	0	No editable

Por ejemplo: Cómo habilitar / ¿Desactivar la función de autocebado?

- 1) **Introduzca la configuración de parámetros:** Apague la bomba y luego sostenga ambos   durante 3 segundos;
- 2) **Seleccionar dirección de parámetro:** Pulse  para seleccionar la dirección 6 ;
- 3) **Activar o desactivar la función de autocebado :** Ajustar pulsando  o , 2 5= Activa, 0=Desactiva .

6 FUNCIONAMIENTO WIFI (ELEMENTO OPCIONAL)

1 Descarga la aplicación iGarden



Android



iOS



2 Registro de cuenta

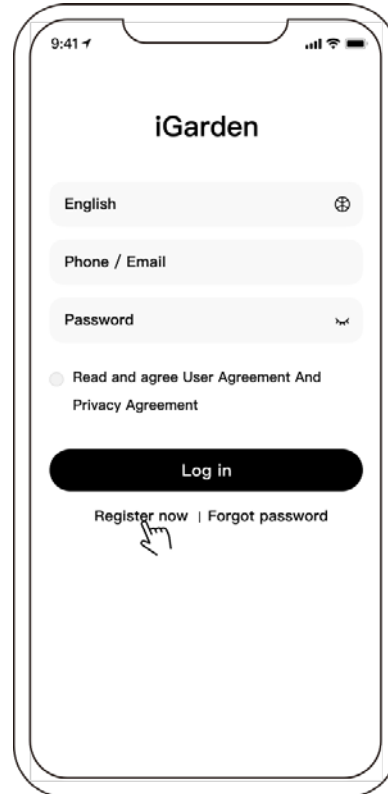

Registro por teléfono/correo electrónico

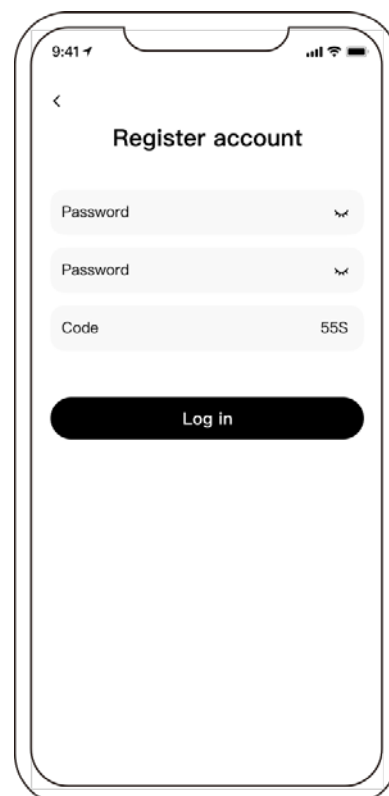
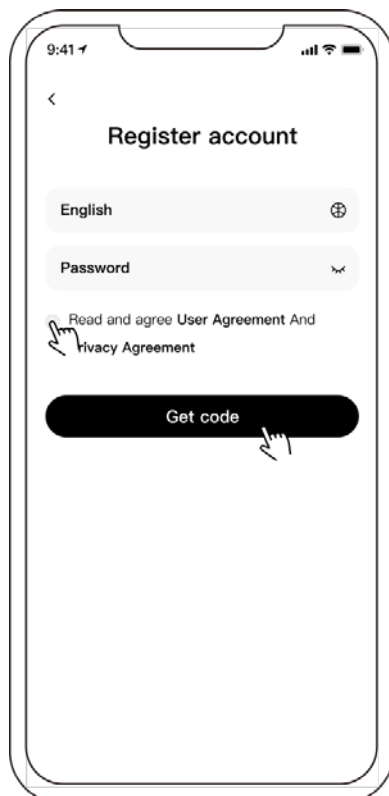



3 Emparejamiento de aplicaciones

Asegúrese de que la bomba esté encendida antes de comenzar.

(Condiciones de la red: 2,4 GHz; las redes de 2,4 GHz y 5 GHz se combinan en una sola SSID; pero no hay una red de 5 GHz separada)

1) Por favor, confirme que su teléfono está conectado a la red Wifi y que el Bluetooth está activado.

2) Mantenga pulsado  durante 3 segundos para desbloquear la pantalla. Tras encender la bomba, mantenga pulsado  durante 5 segundos hasta oír un pitido y suelte.  La luz parpadeará.

3) Haz clic en “Agregar dispositivo” y luego sigue las instrucciones para emparejar el dispositivo.

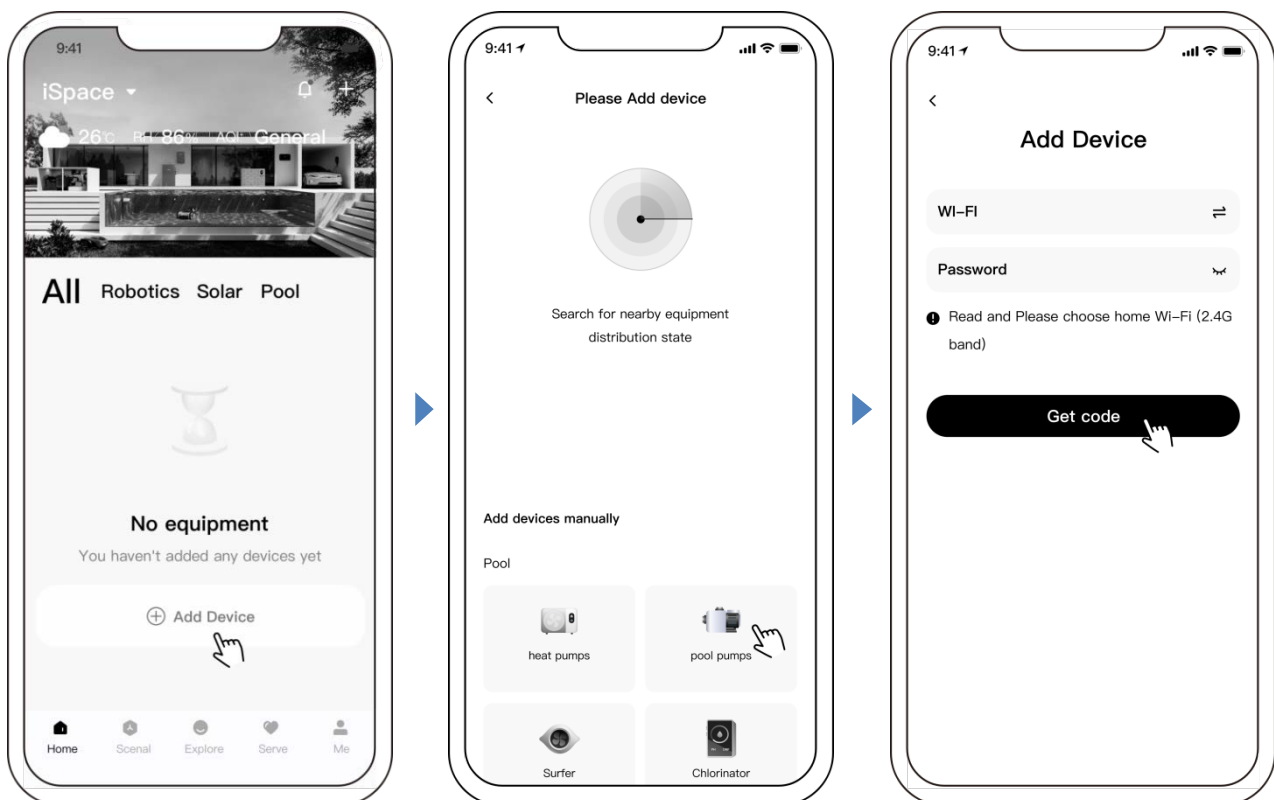

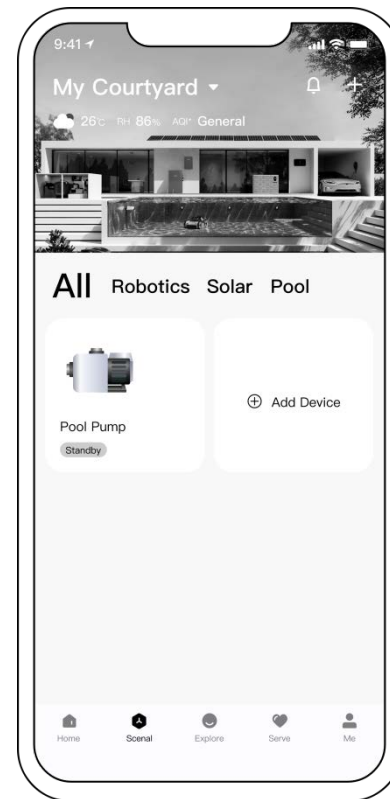
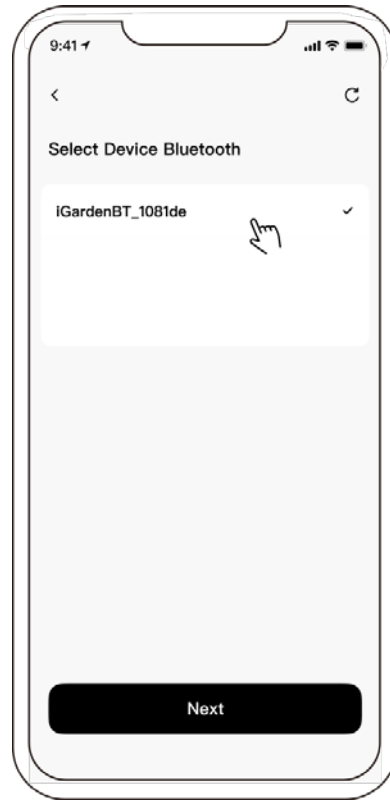
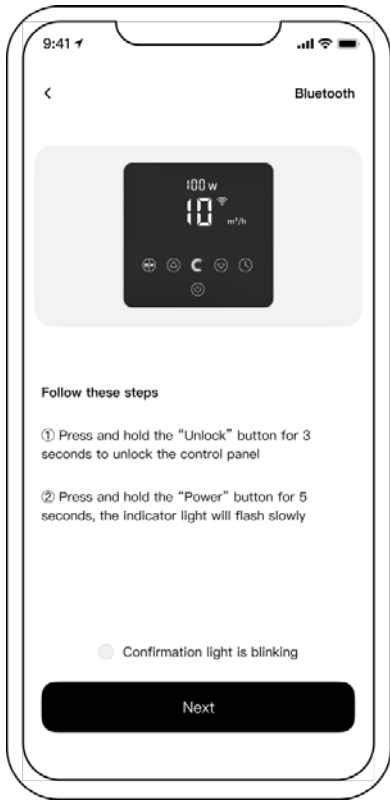

4 Operación

1) Modo de inversor automático (modo AI):

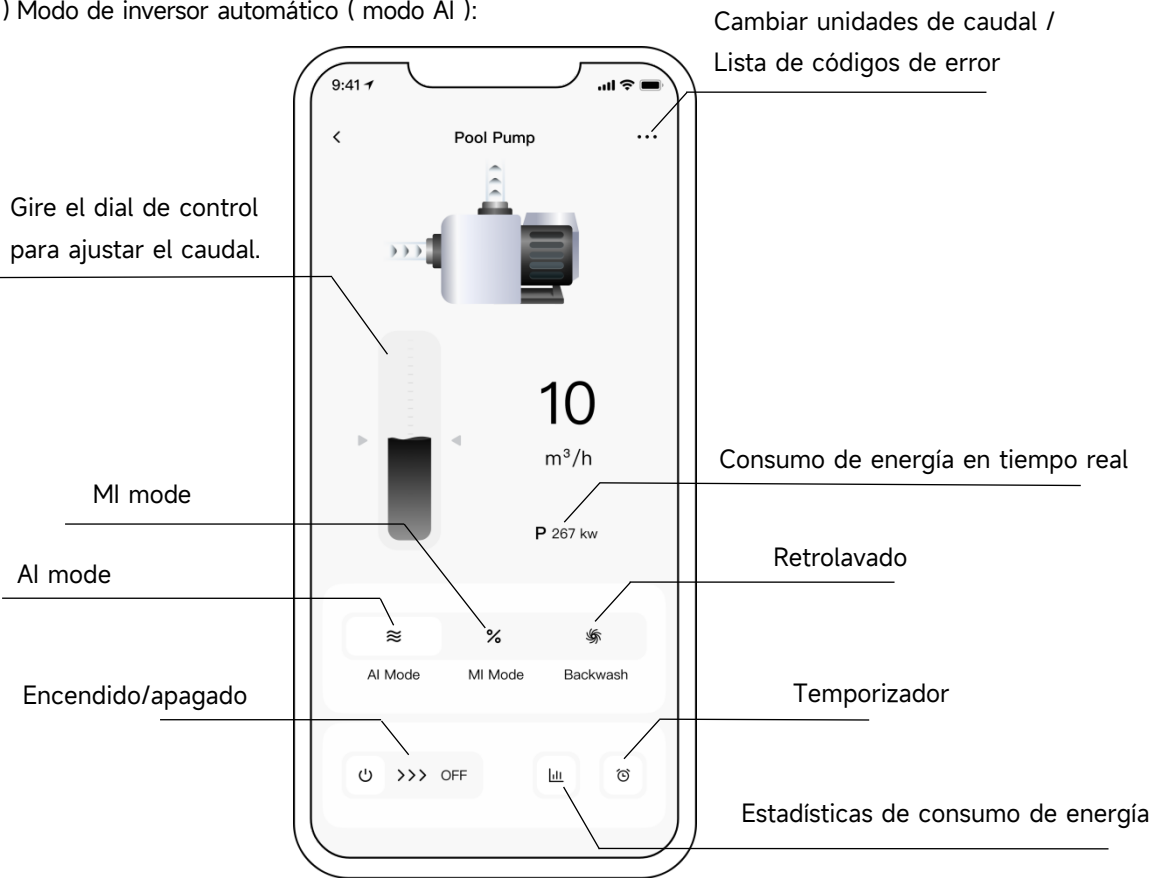

2) Modo inversor manual (modo MI):

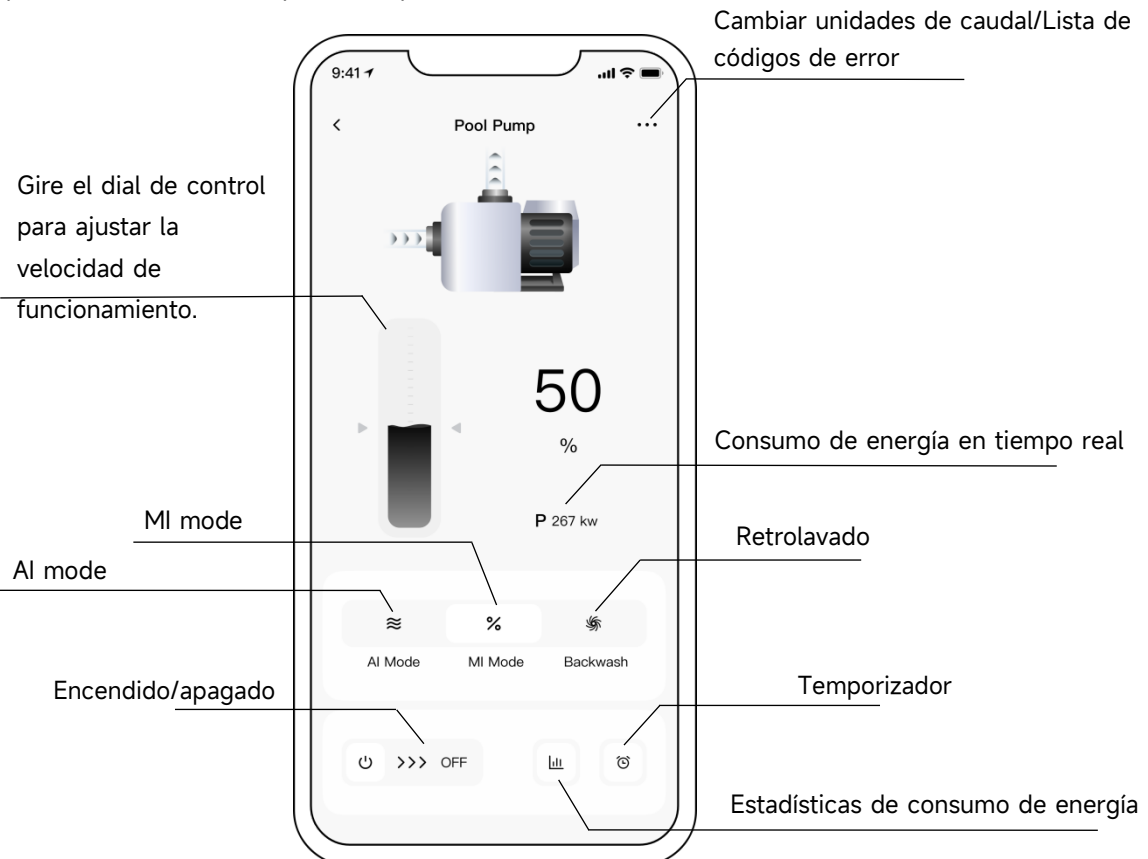

3) Modo de retrolavado:

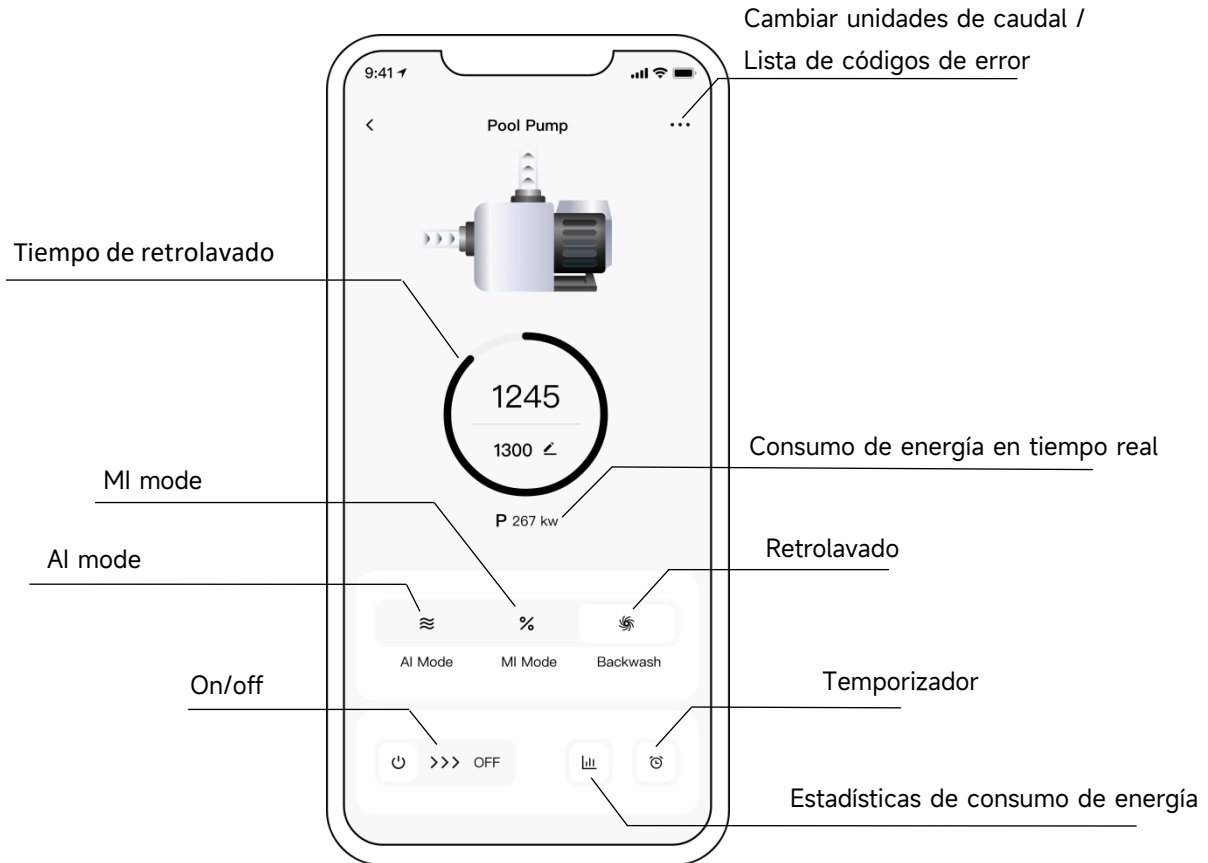

Aviso sobre la configuración del temporizador a través de la aplicación:

- 1) La variación temporal es de ± 30 s;
- 2) Para evitar que los puntos de sincronización se superpongan y entren en conflicto y se invaliden debido a la demora de la red, se recomienda que la hora de finalización y la hora de inicio del siguiente período de sincronización no se superpongan, y que se reserve un intervalo de tiempo suficiente, por ejemplo, al menos 2 minutos;

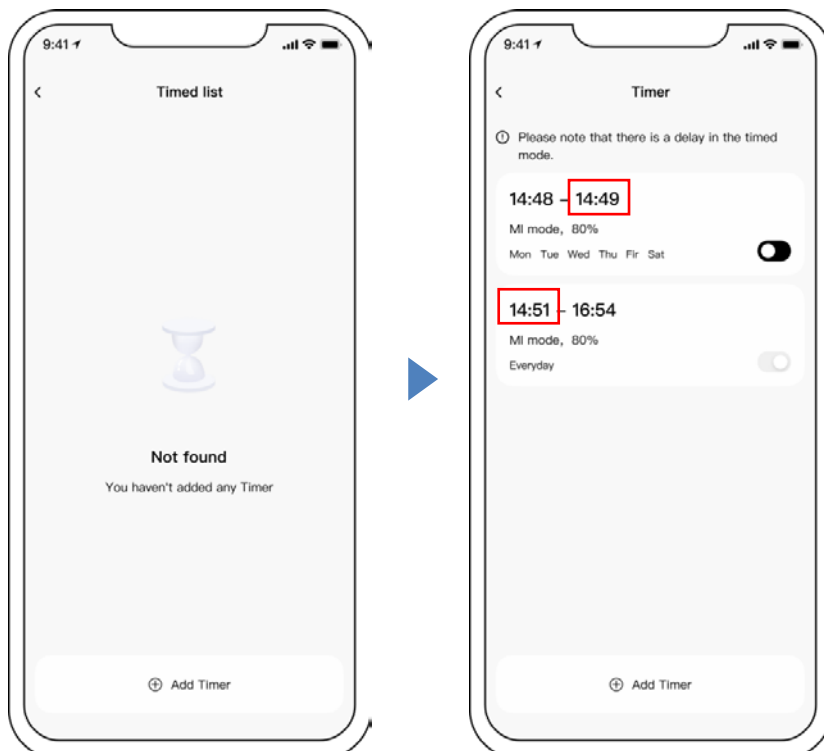

5 Compartir dispositivos con los miembros de tu familia

Los usuarios pueden compartir los dispositivos para que los controlen sus familiares. Por favor, pídeles a sus familiares que registren primero "iGarden" y, a continuación, el administrador podrá operar como se indica a continuación:

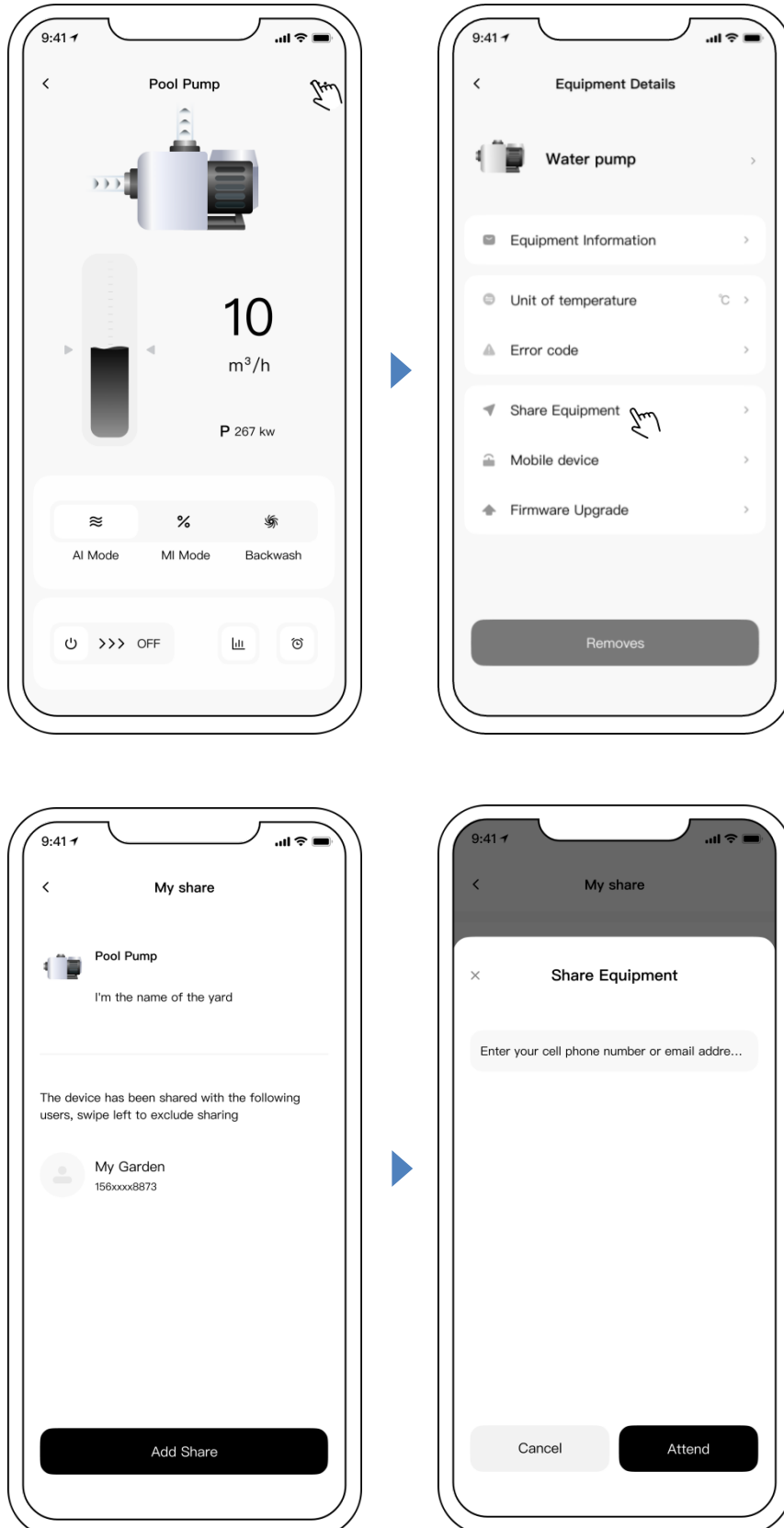

6 Gestión de jardines

En la lista de dispositivos se muestra el patio actual. Tras hacer clic, los usuarios pueden ver o cambiar entre todos los patios actuales, acceder a Gestión de jardines y también a la página de la lista de patios. Como se muestra a continuación:

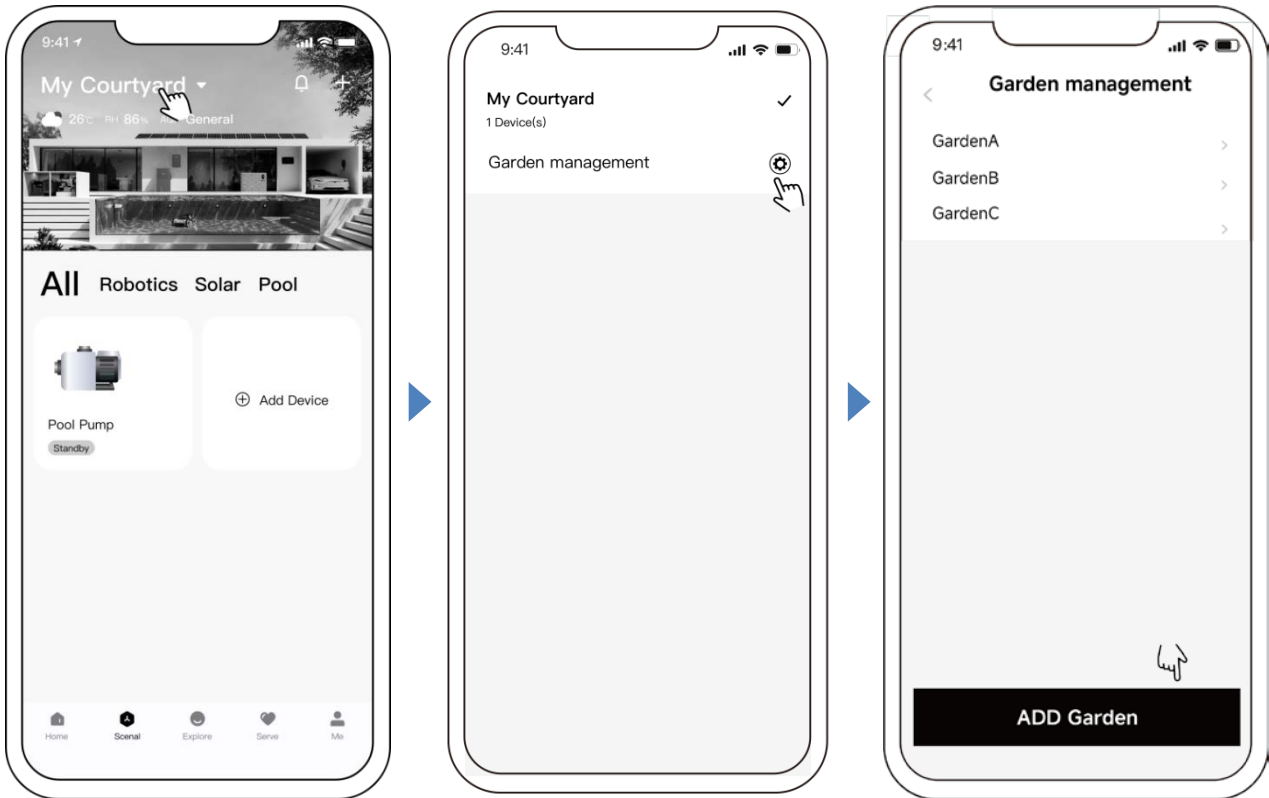

7 Centro de mensajes

A: Ver mensaje: En la página de la lista de dispositivos, haga clic en el icono de mensaje para acceder al centro de mensajes y ver el mensaje correspondiente, como se muestra a continuación: (Incluye: Alarma, Jardín, Notificación)

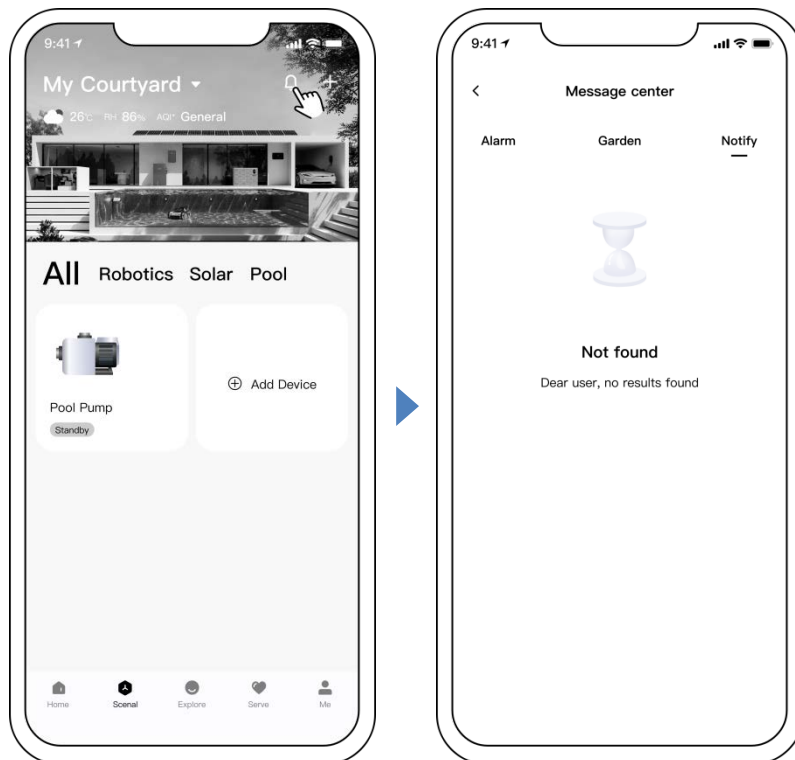

B: Configuración de notificaciones push: En la página de Configuración, haga clic en [Configuración de notificaciones push] para acceder a la página de Configuración de notificaciones push. Los usuarios pueden configurar las notificaciones push según la clasificación del mensaje, como se muestra a continuación:

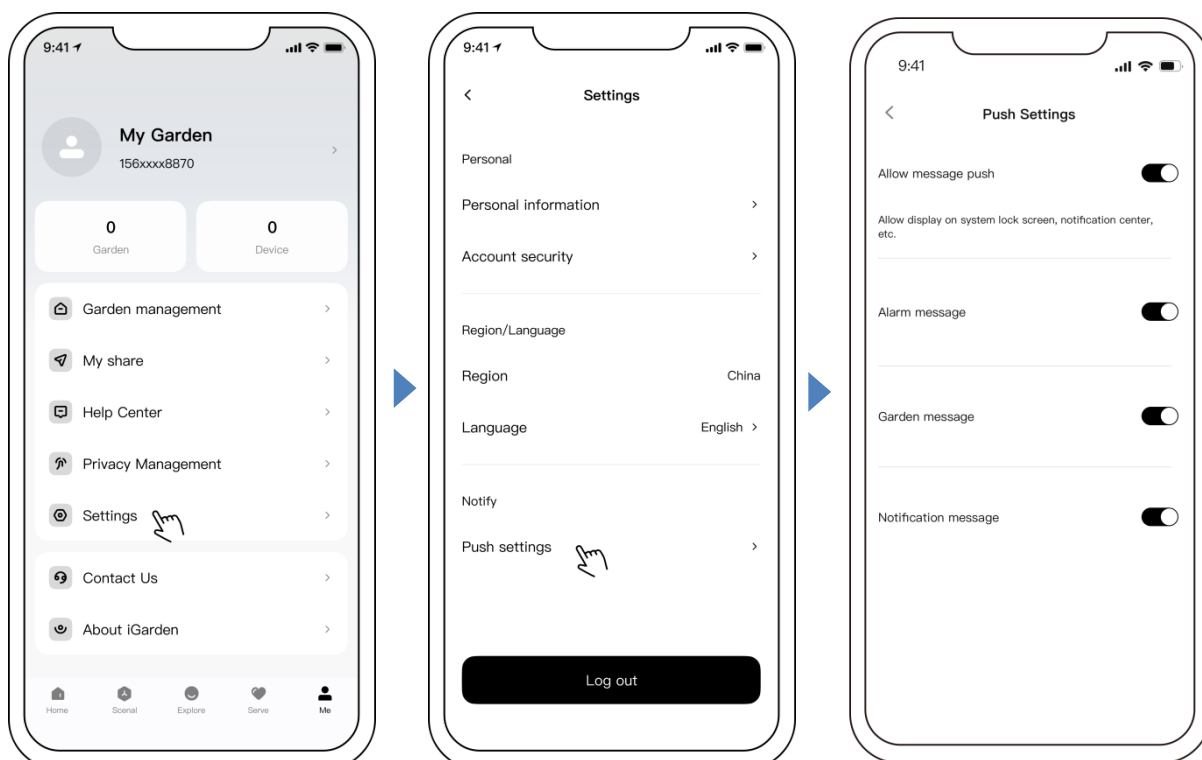

8

Si tiene algún problema al usar el servicio, le invitamos a enviarnos sus comentarios. El proceso es el siguiente:

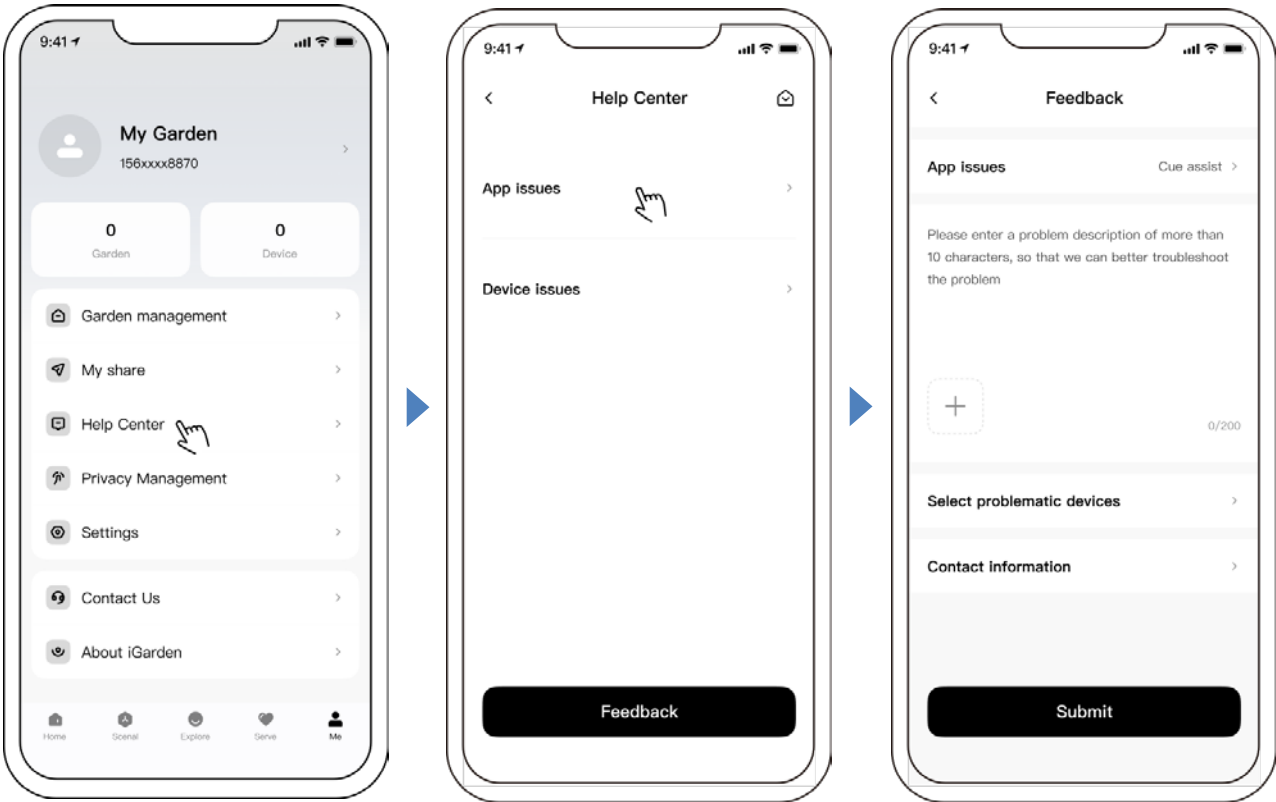

Aviso:

- 1) La previsión meteorológica es solo de referencia;
- 2) Los datos de consumo de energía son solo de referencia, ya que pueden verse afectados por problemas de red e imprecisiones en el cálculo;
- 3) La aplicación está sujeta a actualizaciones sin previo aviso.

7 CONTROL EXTERNO

El control externo se puede habilitar mediante los siguientes contactos. Si se habilita más de un control externo, la prioridad es la siguiente: Entrada digital > RS485 > Control del panel



Figura 5: Ubicación del puerto del conector



Figura 6: Conector de entrada digital y RS485

Entrada de alimentación de CA (apta para 115 V y 230 V)

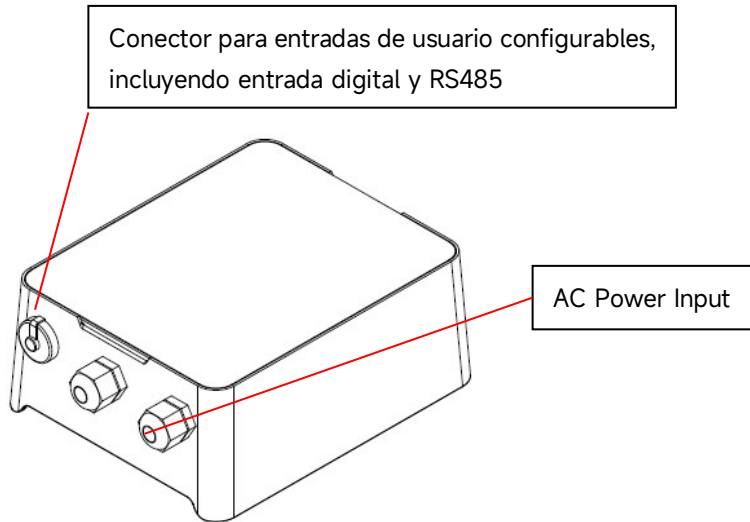

Figura 7 - Conexión del cable de alimentación

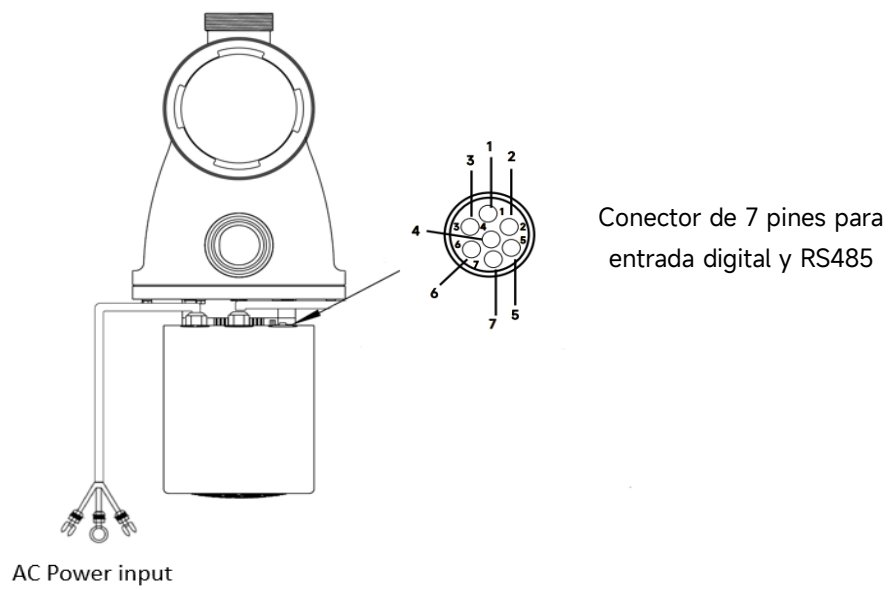
Control externo	Color	Descripción	Nota
Entrada digital	Rojo	Di4 (Entrada digital 4)	Velocidad predeterminada = 40%
	Negro	Di3 (Entrada digital 3)	Velocidad predeterminada = 80%
	Blanco	Di2 (Entrada digital 2)	Velocidad predeterminada = 100%
	Gris	Di1 (Entrada digital 1)	Detener
	Amarillo	Tierra digital (COM)	COM
RS485	Verde	RS485-A	/
	Marrón	RS485-B	/

a. Entrada digital

La capacidad de funcionamiento está determinada por el estado de la entrada digital.

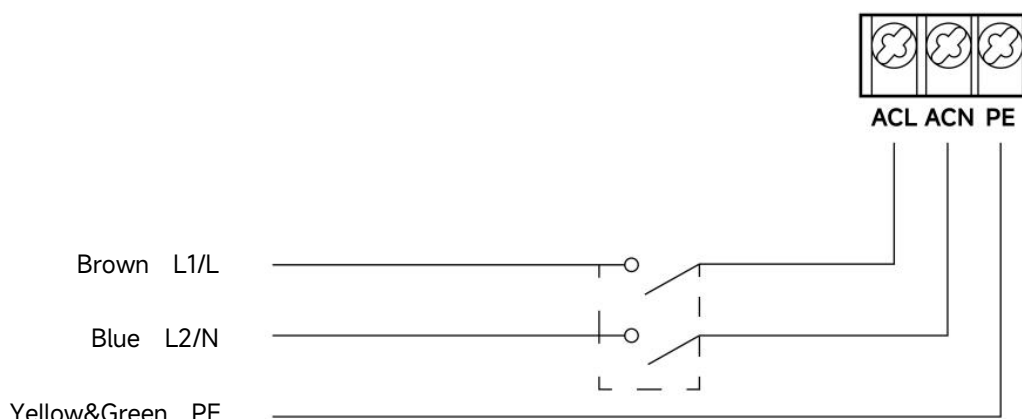
- 1) Cuando Di1 (Gris) se conecta con COM (Amarillo), la bomba deberá detenerse obligatoriamente; si se desconecta, el control digital no será válido;
- 2) Cuando Di2 (Blanco) se conecta con COM (Amarillo), la bomba funcionará obligatoriamente al 100%; si se desconecta, la prioridad de control volverá al control del panel;
- 3) Cuando Di3 (negro) se conecta con COM (amarillo), la bomba deberá funcionar obligatoriamente al 80%; si se desconecta, la prioridad de control volverá al control del panel;
- 4) Cuando Di4 (rojo) se conecta con COM (amarillo), la bomba deberá funcionar obligatoriamente al 40%; si se desconecta, la prioridad de control volverá al control del panel;
- 5) La capacidad de las entradas (Di2/Di3/Di4) podría modificarse según la configuración de los parámetros.

b. RS485

Para conectarse con RS485-A (verde) y RS485-B (marrón), la bomba podría controlarse mediante el protocolo de comunicación Modbus 485.

8 PROTECCIÓN Y FRACASO

8.1 de alta temperatura y reducción de velocidad - AL01

En "Auto Inversor/Manual En los modos «Inversor» y «Temporizador» (excepto retrolavado/autocebado), cuando la temperatura del módulo alcanza el umbral de activación de la alarma de alta temperatura (81 °C), se activa el estado de alarma. Cuando la temperatura desciende al umbral de desactivación de la alarma de alta temperatura (78 °C), se desactiva dicho estado. La pantalla muestra alternativamente AL01 y la velocidad o el caudal .

Si se muestra AL01, la capacidad de funcionamiento se reducirá automáticamente como se indica a continuación:

- 1) Si la capacidad operativa actual es superior al 100 %, la capacidad de funcionamiento se reducirá automáticamente al 85 % ;
- 2) Si la capacidad operativa actual se encuentra entre el 85% y el 100%, la capacidad de funcionamiento se reducirá automáticamente en un 15%.
- 3) Si la capacidad operativa actual se encuentra entre el 70% y el 85%, la capacidad de funcionamiento se reducirá automáticamente en un 10%.
- 4) Si la capacidad operativa actual es inferior al 70%, la capacidad de funcionamiento se reducirá automáticamente en un 5%.

8.2 Protección contra subtensión - AL02

entradas de alimentación de CA de 230 V y 115 V.

① Entrada de alimentación de CA: 230 V

Cuando el dispositivo detecta que la tensión de entrada es inferior a 198 V, limita la velocidad de funcionamiento. La pantalla muestra alternativamente AL02 y la velocidad de funcionamiento o el caudal.

- 1) Cuando la tensión de entrada sea inferior o igual a 180 V, la capacidad de funcionamiento se limitará al 70 %;
- 2) Cuando el rango de voltaje de entrada se encuentra dentro de 180V - 190V, la capacidad de funcionamiento se limitará al 75%;
- 3) Cuando el rango de voltaje de entrada se encuentra dentro de 190V - 198V, la capacidad de funcionamiento se limitará al 85% .

② Entrada de alimentación de CA: 115 V

Cuando el dispositivo detecta que la tensión de entrada es inferior a 98 V, limita la velocidad de funcionamiento. La pantalla muestra alternativamente AL02 y la velocidad de funcionamiento o el caudal.

- 1) Cuando el rango de voltaje de entrada se encuentra dentro de 85V - 90V, la capacidad de

funcionamiento se limitará al 75%;

- 2) Cuando el rango de voltaje de entrada se encuentra dentro de 90V - 98V, la capacidad de funcionamiento se limitará al 85% .

Nota: Si el voltaje de entrada es inferior a 85 V, se mostrará el código de error E001 (Voltaje de entrada anormal, consulte 8.4).

8.3 Solución de problemas

Problema	Posibles causas y solución
La bomba no arranca.	<ul style="list-style-type: none">• Fallo en la fuente de alimentación, cableado desconectado o defectuoso.• Fusibles fundidos o sobrecarga térmica abierta.• Compruebe que el eje del motor gira libremente y sin obstrucciones.• Debido a un largo periodo de inactividad. Desconecte la fuente de alimentación y gire manualmente el eje trasero del motor varias veces con un destornillador.
La bomba no se ceba.	<ul style="list-style-type: none">• Vacíe la carcasa de la bomba/filtro. Asegúrese de que la carcasa de la bomba/filtro esté llena de agua y que la junta tórica de la tapa esté limpia.• Conexiones sueltas en el lado de succión.• Cesta coladora o cesta de espumadera cargada de residuos.• El lado de succión está obstruido.• Si la distancia entre la entrada de la bomba y el nivel del líquido es superior a 2 m, se debe reducir la altura de instalación de la bomba.
Bajo caudal de agua	<ul style="list-style-type: none">• La bomba no se ceba.• Aire que entra en la tubería de succión.• Cesta llena de escombros.• Nivel de agua insuficiente en la piscina.
La bomba hace ruido	<ul style="list-style-type: none">• Fuga de aire en la tubería de succión, cavitación causada por una línea de succión restringida o de tamaño insuficiente o fuga en cualquier junta, bajo nivel de agua en la piscina y líneas de retorno de descarga sin restricciones.• Vibraciones causadas por una instalación incorrecta, etc.• Cojinete del motor o impulsor dañado (es necesario contactar con el proveedor para su reparación).

8.4 Código de error

Cuando el dispositivo detecte un fallo, se detendrá automáticamente y mostrará el código de error . Tras 15 segundos de detención , compruebe si el fallo se ha solucionado . Si se soluciona, la bomba volverá a funcionar .

Artículo	Código de error	Detalles	
1	E001	Descripción	Tensión de entrada anormal : La tensión de alimentación está fuera del rango de 165V a 275V .
		Proceso	La bomba se detendrá automáticamente durante 15 segundos y reanudará su funcionamiento si detecta que el voltaje de la fuente de alimentación se encuentra dentro del rango.
2	E002	Descripción	Sobrecorriente de salida: La corriente pico de la bomba es superior a la corriente de protección.
		Proceso	La bomba se detendrá automáticamente durante 15 segundos y luego Si esto ocurre tres veces seguidas , la bomba se apagará y deberá revisarse . Reiniciado manualmente.
3	E102	Descripción	Disipador de calor Error: La temperatura del disipador de calor alcanza los 91 °C durante 10 segundos . O bien, el sensor del disipador de calor detecta un circuito abierto o un cortocircuito .
		Proceso	1. La bomba se detendrá automáticamente durante 30 segundos y reanudará su funcionamiento si detecta que la temperatura del disipador de calor es inferior a 81 °C. 2. La bomba se detendrá automáticamente durante 15 segundos. y reanudará su funcionamiento si detecta que el sensor del disipador de calor no está abierto ni en cortocircuito .
4	E103	Descripción	Error en la placa controladora principal : El placa controladora principal Está defectuoso.
		Proceso	La bomba se detendrá automáticamente durante 15 segundos y luego Si esto ocurre tres veces seguidas , la bomba se apagará y deberá revisarse . Reiniciado manualmente.
5	E104	Descripción	Protección contra deficiencia de fase: Los cables del motor no están conectados a la placa de control principal .
		Proceso	La bomba se detendrá automáticamente durante 15 segundos y luego Si esto ocurre tres veces seguidas , la bomba se apagará y deberá revisarse . Reiniciado manualmente.
6	E203	Descripción	de lectura de hora RTC : Lectura y escritura La información del reloj temporizador es incorrecta .
		Proceso	El La bomba necesita se apagará y reiniciará manualmente.
7	E204	Descripción	Fallo de lectura de la EEPROM de la placa de visualización : Lectura y escritura la información de La EEPROM de la placa de visualización es incorrecta .
		Proceso	El La bomba necesita se apagará y reiniciará manualmente.

8	E205	Descripción	Error de comunicación : El La comunicación entre la placa de visualización y la placa controladora principal falla y dura 15 segundos.
		Proceso	La bomba se detendrá automáticamente durante 15 segundos. y reanuda el funcionamiento si detecta que la comunicación entre la placa de visualización y la placa controladora principal dura 1 segundo.
9	E207	Descripción	Sin protección contra la humedad : La bomba no tiene agua.
		Proceso	Detenga la bomba manualmente, llénela con agua y vuelva a encenderla. Si esto ocurre dos veces seguidas, la bomba se apagará y deberá revisarse manualmente.
10	E209	Descripción	Pérdida de cebado : La bomba no puede autocebarse debido a razones como exceder el rango de succión o que la tubería es demasiado complicada.
		Proceso	Compruebe que no haya fugas en la bomba o la tubería, luego llene la bomba con agua y reiniciela.

9 MANTENIMIENTO

Vacíe el cestillo del colador con frecuencia. Inspeccione el cestillo a través de la tapa transparente y vacíelo cuando observe una cantidad considerable de basura en su interior. Siga las siguientes instrucciones:

- 1) Desconecte la fuente de alimentación.
- 2). Desenrosque la tapa de la cesta del colador en sentido contrario a las agujas del reloj y retírela.
- 3). Levante la cesta del colador.
- 4). Vacíe los desechos atrapados en la cesta y enjuague los residuos si es necesario.

Nota: No golpee la cesta de plástico contra una superficie dura, ya que podría dañarse.

- 5) Inspeccione la canasta para detectar signos de daños y reemplácela.
- 6) Compruebe que la junta tórica de la tapa no esté estirada, rasgada, agrietada ni presente ningún otro daño.
- 7). Vuelva a colocar la tapa, ajustarla a mano es suficiente.

Nota: Inspeccionar y limpiar periódicamente la cesta del colador ayudará a prolongar su vida útil.

10 GARANTÍA Y EXCLUSIONES

Si durante el período de garantía se detecta algún defecto, el fabricante, a su discreción, reparará o reemplazará el artículo o la pieza en cuestión sin costo alguno para el cliente. Para beneficiarse de la garantía, el cliente deberá seguir el procedimiento de reclamación establecido.

La garantía quedará anulada en caso de instalación incorrecta, funcionamiento incorrecto, uso inapropiado, manipulación o uso de repuestos no originales.

11 DESECHO



Al desechar el producto, clasifique los residuos como residuos de productos eléctricos o electrónicos o entréguelos al sistema local de recogida de residuos.

La recogida selectiva y el reciclaje de los equipos desechados al final de su vida útil

contribuirán a garantizar que se reciclen de forma que se proteja la salud humana y el medio ambiente. Póngase en contacto con su ayuntamiento para obtener información sobre dónde puede depositar su bomba de agua para su reciclaje.

CONTEÚDO

1. ⚠ INSTRUÇÕES IMPORTANTES DE SEGURANÇA	94
2. ESPECIFICAÇÕES TÉCNICAS	95
3. DIMENSÕES GERAIS (mm)	95
4. INSTALAÇÃO	96
5. CONFIGURAÇÃO E OPERAÇÃO	98
6. OPERAÇÃO WI-FI (ITEM OPCIONAL)	108
7. CONTROLE EXTERNO	117
8. PROTEÇÃO E FALHA	119
9. MANUTENÇÃO	122
10. GARANTIA E EXCLUSÕES	122
11. DESCARTE	123

OBRIGADO POR ADQUIRIR AS NOSSAS BOMBAS DE PISCINA COM INVERTER.

ESTE MANUAL CONTÉM INFORMAÇÕES IMPORTANTES QUE O AJUDARÃO A OPERAR E MANTER ESTE PRODUTO.

LEIA O MANUAL ATENTAMENTE ANTES DA INSTALAÇÃO E OPERAÇÃO E GUARDE-O PARA REFERÊNCIA FUTURA.

1. INSTRUÇÕES DE SEGURANÇA IMPORTANTES

Ao instalar e utilizar este equipamento elétrico, devem sempre ser seguidas as precauções básicas de segurança, incluindo as seguintes:

- 1) LEIA E SIGA TODAS AS INSTRUÇÕES
- 2) AVISO – Para reduzir o risco de lesões, não permita que crianças usem este produto, a menos que estejam sob supervisão constante e rigorosa.
- 3) AVISO – Risco de choque elétrico. Ligue apenas a um circuito derivado protegido por um dispositivo de corrente residual (RCD) com uma corrente residual nominal que não exceda 30 mA. Contacte um eletricitista qualificado se não conseguir verificar se o circuito está protegido por um dispositivo de corrente residual RCD.
- 4) PARA EVITAR O RISCO DE CHOQUE ELÉTRICO, conecte o fio terra do motor (verde/amarelo) ao sistema de aterramento.
- 5) AVISO – Para reduzir o risco de choque elétrico, substitua o cabo danificado imediatamente.
- 6) Não instale dentro de um compartimento externo ou sob a saia de uma banheira de hidromassagem ou spa.
- 7) Um seccionador deve ser instalado na instalação elétrica fixa, de acordo com as normas de instalação.
- 8) Para uso em piscinas, banheiras de hidromassagem e spas.
- 9) CUIDADO: Para reduzir o risco de choque elétrico, instale a pelo menos 1,8 metros das paredes internas da piscina. Não use extensão.
- 10) CUIDADO: Para garantir a proteção contínua contra riscos de choque elétrico, utilize somente peças de reposição idênticas durante a manutenção .
- 11) Esta bomba destina-se ao uso em piscinas fixas, enterradas ou acima do solo, e também pode ser usada em banheiras de hidromassagem e spas com temperatura da água inferior a 50 °C . Devido ao método de instalação fixa, não é recomendável o uso desta bomba em piscinas acima do solo que possam ser facilmente desmontadas para armazenamento.
- 12) A bomba não é submersível.
- 13) Nunca abra a parte interna da caixa do motor de acionamento
- 14) GUARDE ESTAS INSTRUÇÕES.

AVISO:

- Encha a bomba com água antes de ligá-la. Não deixe a bomba funcionar a seco. Caso funcione a seco, o selo mecânico será danificado e a bomba começará a vazar.
- Antes de realizar qualquer manutenção na bomba, desligue a energia da bomba desconectando o circuito principal e libere toda a pressão da bomba e do sistema de tubulação.
- Nunca aperte ou afrouxe os parafusos enquanto a bomba estiver em funcionamento.
- Certifique-se de que a entrada e a saída da bomba estejam desobstruídas, sem qualquer material estranho.

2. ESPECIFICAÇÕES TÉCNICAS

Modelo	Volume recomendado da piscina (m ³)	P1	Tensão (V/Hz)	Qmáx (m ³ /h)	Hmax (m)	Circulação (m ³ /h)	
		KW				Aos 10 metros	Aos 8m
DCP12-IG	40-70	1.2	220-240/ 50/60	28,0	21.0	23.0	26.0

3. DIMENSÕES GERAIS (mm)



Figura 1 - Dimensões da bomba

4. INSTALAÇÃO

4.1 Localização da bomba

- 1) Instale a bomba o mais próximo possível da piscina. Para reduzir a perda por atrito e melhorar a eficiência, utilize tubulações curtas e diretas de sucção e retorno.
- 2) Para evitar a incidência direta da luz solar, do calor ou da chuva, recomenda-se colocar a bomba em local coberto ou à sombra.
- 3) NÃO instale a bomba em locais úmidos ou sem ventilação. Mantenha a bomba e o motor a pelo menos 150 mm de distância de obstáculos, pois os motores das bombas necessitam de livre circulação de ar para refrigeração.
- 4) A bomba deve ser instalada na horizontal e fixada no orifício do suporte com parafusos para evitar ruídos e vibrações desnecessárias.

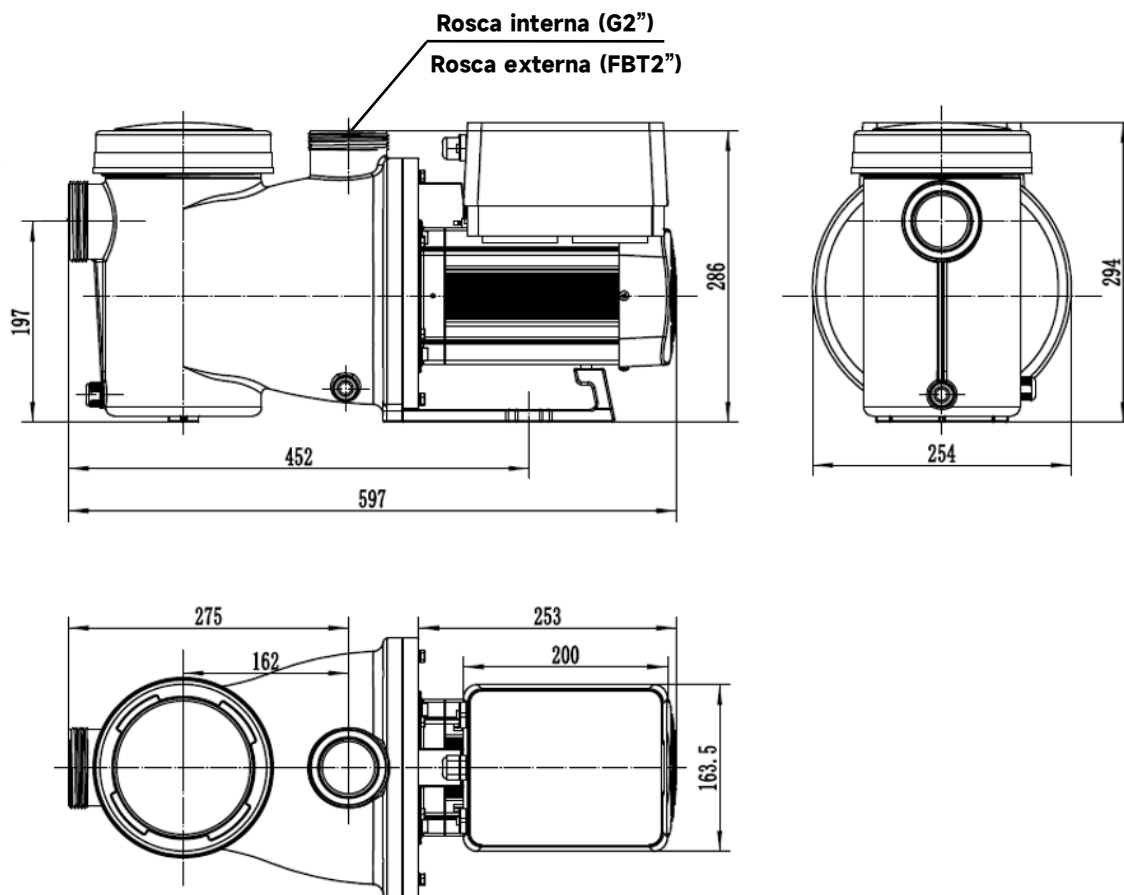
4.2 Encanamento e válvulas

- 1) Tamanho da união de entrada/saída da bomba: opcional com medidas métricas (50 ou 63 mm) ou imperiais (1,5 " ou 2").
- 2) Para otimizar o sistema hidráulico da piscina, deve-se utilizar tubos de maior diâmetro. Recomenda-se o uso de tubos com 2 polegadas de diâmetro.
- 3) Ao instalar as conexões (juntas) de entrada e saída na tubulação, utilize o selante especial para material de PVC.
- 4) A dimensão da linha de sucção deve ser igual ou maior que o diâmetro da linha de entrada, para evitar que a bomba aspire ar, o que afetará a eficiência da bomba.
- 5) Para reduzir a perda por atrito e melhorar a eficiência, a tubulação nos lados de sucção e retorno deve ser curta e direta.
- 6) Sistemas de sucção inundados devem ter válvulas instaladas tanto na linha de sucção quanto na linha de retorno da bomba, o que facilita a manutenção de rotina. Uma válvula, cotovelo ou conexão em T instalada na linha de sucção não deve estar a uma distância da frente da bomba inferior a sete vezes o diâmetro da linha de sucção.
- 7) Utilize uma válvula de retenção na linha de retorno onde houver uma altura significativa entre a linha de retorno e a saída da bomba, para evitar o impacto da recirculação do fluido e o golpe de aríete que pode causar a parada da bomba .

4.3 Acessórios

- 1) Os cotovelos devem estar a uma distância mínima de 350 mm da entrada. Não instale cotovelos de 90° diretamente na entrada/saída da bomba. As juntas devem estar bem apertadas.
- 2) As articulações devem estar firmes.



Figura 2 - Instalações de canalização e acessórios

* Tamanho da união de entrada/saída da bomba: opcional com medidas métricas (50 ou 63 mm) ou imperiais (1,5 " ou 2")

- 3) Utilize o KIT DE UNIÃO fornecido pelo fabricante da bomba (consulte a Figura 3). Não utilize outras conexões para ligar a entrada/saída da bomba, pois as conexões podem não ser compatíveis e danificar corpo da bomba.

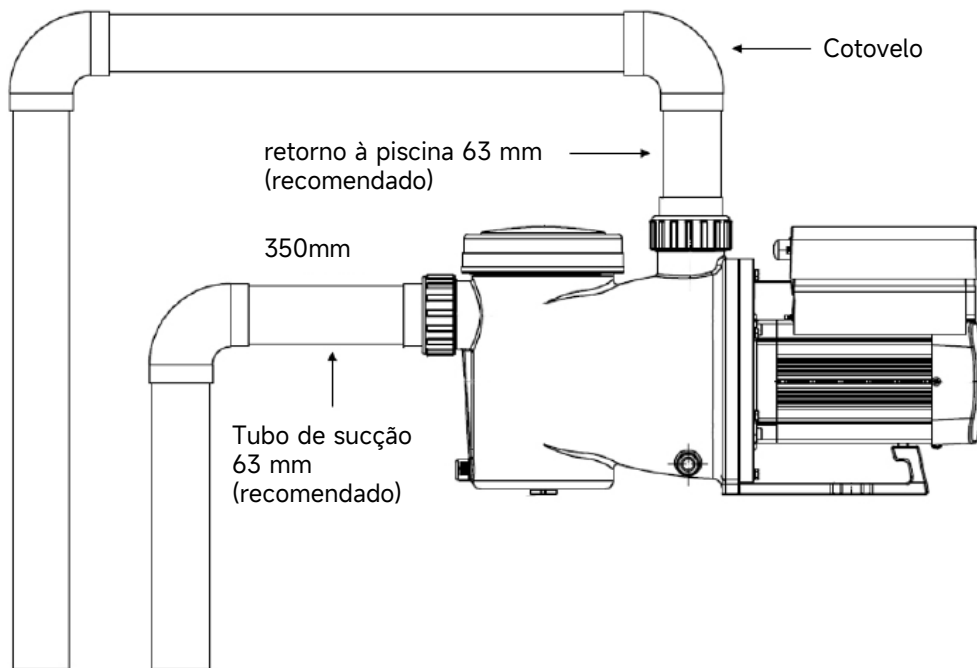

Figura 3 - Kit de união

4.4 Verifique antes da inicialização.

- 1) Verifique se o eixo da bomba gira livremente;
- 2) Verifique se a tensão e a frequência da fonte de alimentação estão de acordo com as especificações da placa de identificação;
- 3) Olhando de frente para a hélice do ventilador, o sentido de rotação do motor deve ser no sentido horário;
- 4) É proibido ligar a bomba sem água.

4.5 Condições de aplicação

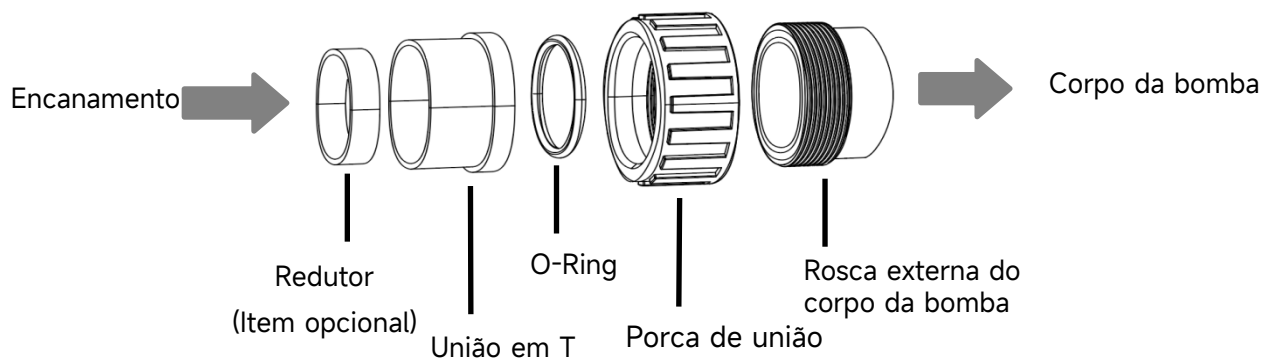
Temperatura ambiente	Instalação interna, faixa de temperatura: -10-42°C
Temperatura máxima da água	50°C
Água salgada disponível	Concentração de sal até 3,5%, ou seja, 35 g/l
Umidade	≤90% UR, (20°C±2°C)
Instalação	A bomba pode ser instalada a uma altura máxima de 2 metros acima do nível da água.
Proteção	Classe F, IP55

5 CONFIGURAÇÃO E OPERAÇÃO



5.1 Exibição no painel de controle

	① Consumo de energia
	② Capacidade operacional / Vazão
	③ Indicador de Wi-Fi (item opcional)
	④ Unidade de fluxo
	⑤ Período do temporizador
	⑥ Temporizador 1/2/3/4
	Retrolavagem/destravamento
	Para cima/para baixo: para alterar o valor da configuração.
	Alternar entre Manual Modo inversor e Auto Modo inversor Manual Modo inversor : A capacidade de funcionamento ser á definida manualmente entre 30% e 120 %. Auto Modo Inversor : A capacidade de funcionamento será ajustada automaticamente entre 30% e 120 %, de acordo com a vazão predefinida. O modo padrão é Manual Inversor modo.
	Configuração do temporizador
Ligado/Desligado	

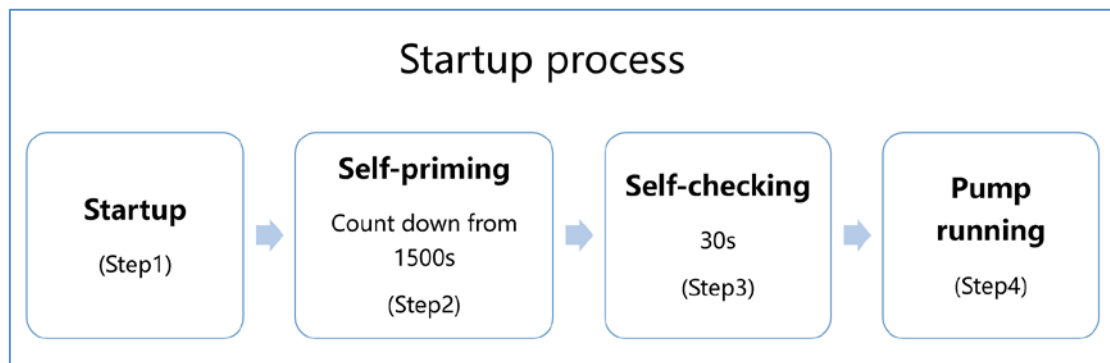
5.2 Comece processo visão geral



① Etapa 1 : Inicialização

- Pressione e segure  por mais de 3 segundos para desbloquear a tela .
- Imprensa  para comece o bombear.

② Etapa 2 : Auto - ativação

- O bombear vai começar Contagem regressiva a partir de 1500 segundos ; quando o sistema detectar que a bomba está cheia de água, a contagem regressiva será interrompida e a escorva será encerrada automaticamente.
- Os usuários podem inserir a configuração do parâmetro para desativar a função de autoinicialização padrão (consulte 5.11) .



③ Etapa 3 : Autoverificação

- O bombear Vou verificar novamente por 30 segundos para garantir que a auto-escorva (Etapa 2) esteja concluída .

④ Etapa 4 : Bombear correndo

- A bomba funcionará com 80% da sua capacidade operacional na partida inicial após a autoescorva.

5.3 Comece

Quando a energia for ligada, a tela irá. Após 3 segundos com a tela totalmente acesa, o código do dispositivo será exibido e, em seguida, ele entrará em funcionamento normal. Quando a tela estiver bloqueada, apenas a botão  a tela acenderá; pressione e segure  por mais de 3 segundos para desbloqueá-la. A tela bloqueará automaticamente após 1 minuto de inatividade e o brilho será reduzido para 1/3 do normal. Pressione rapidamente  para ativar a tela e observar os parâmetros de operação.

5.4 Auto-ajustável

Cada vez que a bomba for ligada, ela iniciará o processo de autoescurvamento.

Quando a bomba funciona Autoajustável, fará a contagem regressiva para começar. A partir de 1500 segundos, a contagem regressiva para automaticamente quando o sistema detecta que a bomba está cheia de água. Em seguida, o sistema verifica novamente por 30 segundos para garantir que a autoescorva esteja completa.



O usuário pode cancelar a inicialização automática manualmente pressionando  por mais de 3 segundos. A bomba entrará no modo Inversor Manual padrão na inicialização.

Observação:

a função de autoescurvamento ativada. Cada vez que a bomba for reiniciada, ela realizará o autoescurvamento automaticamente. Os usuários podem acessar as configurações de parâmetros para desativar a função de autoescurvamento padrão (consulte 5.11).

5.5 Retrolavagem











O usuário pode iniciar a retrolavagem ou a recirculação rápida em qualquer estado de funcionamento pressionando .

	Padrão	Intervalo de configuração
Tempo	anos 180	Pressione  ou  para ajustar de 0 a 1500 segundos, com 30 segundos para cada etapa.
Capacidade de funcionamento	100%	60-100%, insira a configuração do parâmetro (consulte 5.11)

Saída de refluxo:

Quando o modo de retrolavagem estiver ativado, o usuário pode pressionar e segurar  por 3 segundos para cancelá-lo; a bomba retornará ao estado anterior à retrolavagem. Se um limite de velocidade for definido pelo usuário, a capacidade de operação da retrolavagem não excederá o limite de velocidade definido. (ver 5.10)

5.6 Manual Modo inversor

1		Mantenha pressionado  por mais de 3 segundos para desbloquear a tela .
2		Pressione  para iniciar. A bomba funcionará com 80% da capacidade operacional na inicialização após a autoescorva.
3	 	Pressione  ou  para definir a capacidade de funcionamento entre 30% e 120%, em incrementos de 5% .
4		Pressione  novamente para alternar para o modo Inversor Automático.











Observação :

- 1) Quando a pressão na tubulação estiver alta, para manter uma vazão adequada, o usuário pode ajustar a capacidade de operação para 105% a 120%. A bomba funcionará em uma velocidade maior para vencer a alta pressão na tubulação.
- 2) Na faixa de 105% a 120% da capacidade de funcionamento, a bomba ajustará automaticamente a velocidade ao atingir a potência máxima.
- 3) Por exemplo, quando o usuário ajusta a velocidade para 110 %, se a bomba A potência atingiu o valor máximo nesta velocidade. Neste momento, mesmo que o usuário continue aumentando a velocidade da bomba para 120%, a bomba manterá a velocidade na potência máxima, ou seja, 110 % . E a velocidade exibida cairá de 120% para 110%.

5.7 Auto Modo inversor

No modo Inversor Automático, a bomba pode detectar automaticamente a pressão do sistema e ajustar a velocidade do motor para atingir a vazão definida.

1		Desbloqueie a tela e pressione  para alternar do modo Inversor Manual para o modo Inversor Automático.
---	---	---

2	 	A vazão pode ser ajustada pressionando o botão  ou  com incrementos de 1 m ³ /h para cada nível.
3	 	A unidade de vazão pode ser alterada para L /min , IMP gpm ou US gpm , pressionando ambas as teclas.   por 3 segundos .
4		Pressione  para alternar para o modo Inversor Manual .

A faixa de vazão ajustável padrão para o Inverk é a seguinte :

Modelo	de vazão ajustável *
DCP12-IG	8-25 m ³ /h

*** Observação :**









No modo Inversor Automático, a vazão máxima ajustável é baseada em uma altura manométrica de aproximadamente 8 metros.



Se o usuário definir a vazão na taxa de vazão máxima ajustável e a pressão na tubulação for superior a 8 m, nessa situação a bomba aumentará automaticamente a velocidade de operação e a potência de entrada para contrabalançar a alta pressão e manter a vazão máxima definida pelo usuário.

Quando a velocidade do motor e a potência de entrada aumentam até o nível máximo, mas não são suficientes para vencer a enorme pressão na tubulação, a vazão exibida no controlador da bomba cairá da vazão definida para a vazão real alcançável .

5.8 Modo temporizador

A capacidade de ligar/desligar e de funcionamento da bomba pode ser controlada por um temporizador, que pode ser programado diariamente conforme necessário.

1	Insira a configuração do temporizador pressionando 
2	Pressione  ou  para definir a hora local.
3	Pressione  para confirmar e ir para a configuração de tempo 1.
4	Imprensa  ou  para escolher os períodos de funcionamento desejados , a capacidade de funcionamento ou a taxa de fluxo. (Quando o ícone % estiver piscando, os usuários podem alterar a taxa de fluxo pressionando 
5	 Repita os passos acima para configurar o outros 3 temporizadores

6	 Mantenha pressionado por 3 segundos para salvar a configuração e ativar o modo temporizador.
7	 Ou  verifique os 4 temporizadores para garantir que não haja nenhuma configuração inválida.

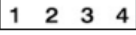

Observação:

1) Se o período de tempo definido incluir a hora atual, a bomba começará a funcionar de acordo com a capacidade de funcionamento ou vazão definida , conforme indicado pelo temporizador atual.

 (1 ou 2 ou 3 ou 4) acenderá , e a área **00:00 - 00:00** exibirá o período de tempo correspondente .

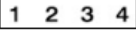
2) Se o período de tempo definido não contiver a hora atual, o número do temporizador será usado.

 (1, 2, 3 ou 4) que está prestes a começar a funcionar será exibido e piscará , e a área **00:00 - 00:00** exibirá o período de tempo correspondente .

3) Durante a configuração do temporizador, se desejar retornar à configuração anterior, mantenha pressionados ambos os botões.   por 3 segundos. Se você não precisar configurar todos os 4 temporizadores, pode manter pressionado  por 3 segundos; o sistema salvará automaticamente o valor definido e ativará o modo temporizador.



4) As configurações de temporizador da bomba foram limitadas; os usuários não poderão configurar temporizadores sobrepostos.



5) Após o temporizador ser configurado e o usuário desligar a bomba, ao ligá-la novamente, ela retornará ao modo de temporizador.

6) Os usuários podem cancelar o modo temporizador pressionando .

5.9 Skimmer Modo

O modo skimmer permite que a bomba remova os detritos da superfície da água, evitando o acúmulo de sujeira e proporcionando uma piscina mais limpa.

Mantenha pressionado  para  acessar a interface predefinida do modo skimmer. Ao alternar para este modo pela primeira vez, a predefinição 1 será ativada.

Os usuários podem pressionar  ou  para visualizar as 4 predefinições. Os detalhes de cada predefinição estão abaixo. A predefinição selecionada será ativada após 5 segundos sem nenhuma operação.

Reinicialização P	Skimmer	Duração do skimmer	Velocidade do skimmer	Período de tempo	Observação
1	1 hora	3 minutos	100%	7:00 – 21:00	Editável em configuração de parâmetros
2	1 hora	10 minutos	100%	7:00 – 21:00	Não editável
3	3 horas	3 minutos	80 %	7:00 – 21:00	Não editável
4	Desative o modo skimmer				Não editável

Tabela 1 - Predefinições do modo skimmer

Durante a duração do skimmer, o controlador exibirá o parâmetro da predefinição, que o usuário poderá manter pressionado.  A cada 3 segundos, a duração do skimmer será cancelada . Ao término da duração do skimmer, a bomba retornará ao estado normal para que o usuário possa operá-la.

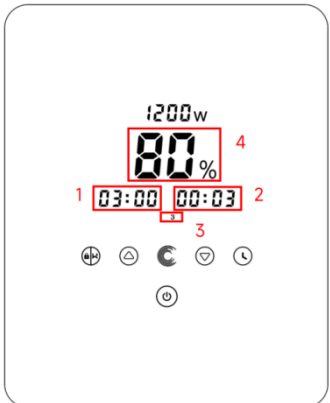
	<ol style="list-style-type: none"> 1. skimmer (hora) 2. skimmer (minutos) 3. Número predefinido do modo Skimmer 4. Velocidade /vazão do skimmer
---	---



Figura 4 - Ciclo do skimmer

5.10 Limite de velocidade /fluxo

Os usuários podem definir o limite de velocidade /vazão da bomba para atender à necessidade de vazão de outros equipamentos, como filtros de areia.



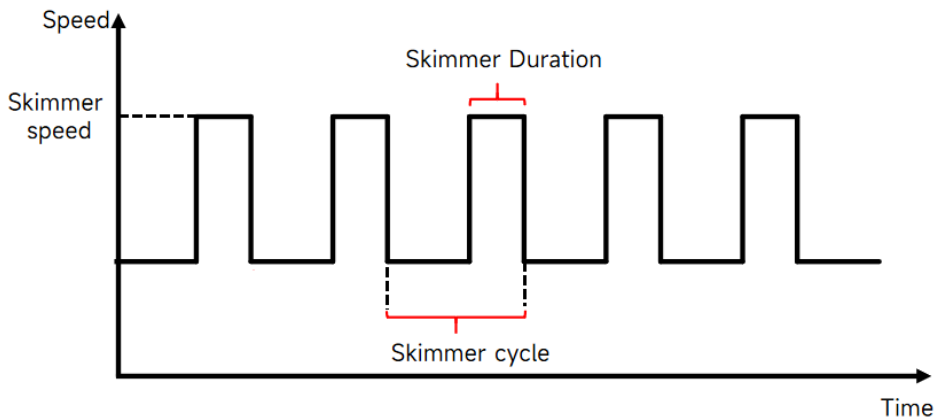





A velocidade / limite de fluxo da bomba pode ser definido nas configurações de parâmetros. (ver 5.11)



100% significa que não há limite de velocidade e a capacidade de funcionamento pode ser definida entre 30% e 120% em condições normais de operação.



Modelo	Limite de velocidade/fluxo	
	Velocidade máxima de corrida	Vazão máxima
DCP12-IG	60%-100%	15-25 m ³ /h

Para garantir o desempenho, o processo de auto -escorvamento em cada inicialização não será limitado pela função de limite de velocidade /fluxo.



5.11 Configuração de parâmetros

Restaurar configurações de fábrica	Desligue a bomba e, em seguida, segure ambos   por 3 segundos
Verifique a versão do software.	Desligue a bomba e, em seguida, segure ambos   por 3 segundos
Insira a configuração do parâmetro conforme abaixo.	Desligue a bomba e, em seguida, segure ambos   por 3 segundos; Imprensa  Para selecionar o endereço do parâmetro, pressione  ou  para ajustar a configuração do parâmetro.



Parâmetro Endereço	Descrição	Configuração padrão	Intervalo de configuração
1	Di2 (Entrada digital 2)	Velocidade: 100%	Velocidade: 30-120%, em incrementos de 5% ;
2	Di3 (Entrada digital 3)	Velocidade: 80 %	Vazão: 1 m ³ /h incrementos; DCP12-IG: 8-25 m ³ /h
3	Di4 (Entrada digital 4)	Velocidade: 40 %	Nota : Pressione  para mudar para fluxo avaliar contexto .
4	Retrolavagem	Velocidade: 100%	Velocidade: 60-100% , em incrementos de 5%; Vazão: 1 m ³ /h incrementos; DCP12-IG: 8-25 m ³ /h Nota : Pressione  para mudar para fluxo avaliar contexto.
5	Modo de controle da entrada analógica	0	0: Controle de corrente 1: Controle de tensão
6	Ative ou desative a inicialização automática a cada partida.	25	25: permite 0: desativa
7	Reservado	0	Não editável
8	Tempo do sistema	00:00	00:00 - 23:59

9	Preinicia 1 do modo skimmer	Ciclo do skimmer : 0 1:00 Duração do skimmer : 00:03 Velocidade do skimmer : 100 %	* Ciclo do skimmer: 1 - 24h, 1h para cada etapa ; * Duração do processo de escaldar: 1 - 30 min, 1 min para cada etapa ; * Velocidade do espremedor: 30%-100%, em incrementos de 5%; * Fluxo do skimmer: 1 m ³ /h incrementos; DCP12-IG: 8-25 m ³ /h Nota : Pressione  para mudar para fluxo avaliar contexto.
10	Período de tempo da predefinição 1 do modo skimmer	7:00 - 21:00	Horário de início: 00:00 - 24:00 Horário de término: 00:00-24:00
11	Limite de velocidade	Velocidade: 100%	Velocidade : 60 % a 100%, em incrementos de 5%; (100% significa sem limite de velocidade) Vazão baixa: 1 m ³ /h incrementos; DCP12-IG : 15-25 m ³ /h Nota : Pressione  para mudar para fluxo avaliar contexto .
12	RS485	170(0xAA)	160-190 (0xA0-0xBF), cada passo por 1.
13	Reservado	0	Não editável

Por exemplo: Como habilitar / Desativar a função de autoinicialização?

1) **Insira a configuração do parâmetro:** Desligue a bomba e, em seguida, segure ambos   por 3 segundos;

2) **Selecione o endereço do parâmetro:** Pressione  para selecionar o endereço 6 ;

Ativar ou desativar a função de autoinicialização : Ajuste pressionando  ou , 2 5= Ativa, 0=Desativa .

6 OPERAÇÃO WI-FI (ITEM OPCIONAL)

1 Descarregue a aplicação iGarden



Android



iOS



2 Registo de conta

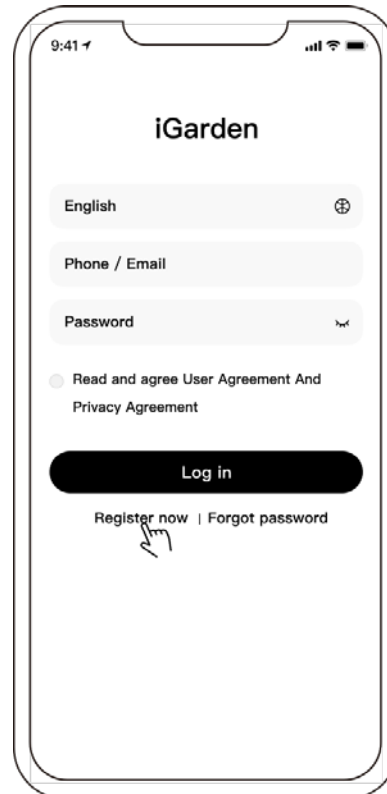

Cadastro por telefone/e-mail

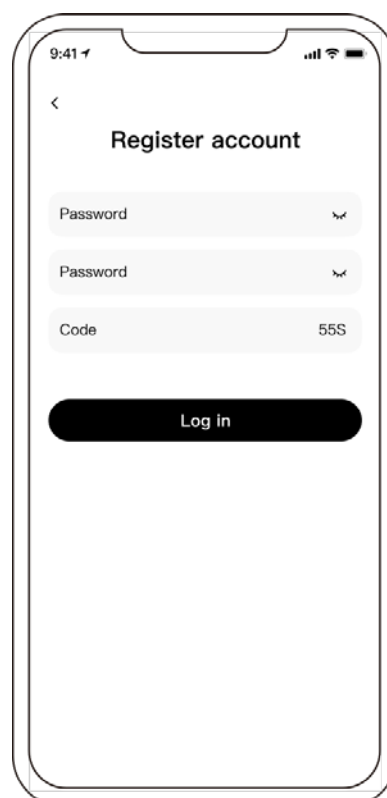
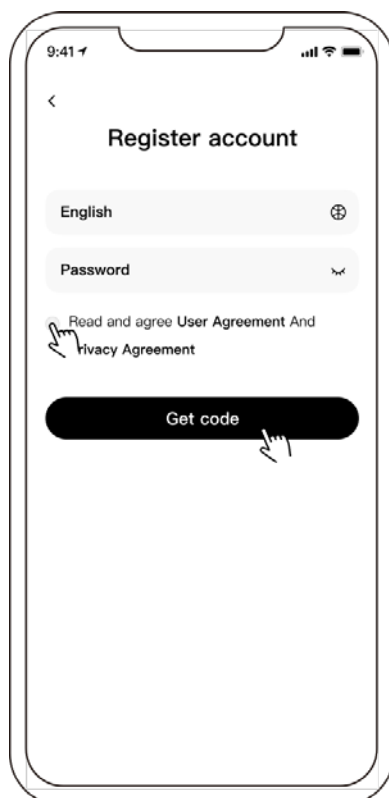



3 Emparelhamento de aplicativos

Certifique-se de que a bomba esteja ligada antes de começar.

(Condição da rede: 2,4 GHz; as redes de 2,4 GHz e 5 GHz combinam-se num único SSID; mas não existe uma rede de 5 GHz separada)

1) Por favor, confirme se o seu telefone está conectado ao Wi-Fi e se o Bluetooth está ativado.

2) Pressione  por 3 segundos para desbloquear a tela. Após ligar a bomba, pressione  por 5 segundos até ouvir um "Bip" e então solte.  O visor piscará.

3) Clique em "Adicionar dispositivo" e siga as instruções para emparelhar o dispositivo.

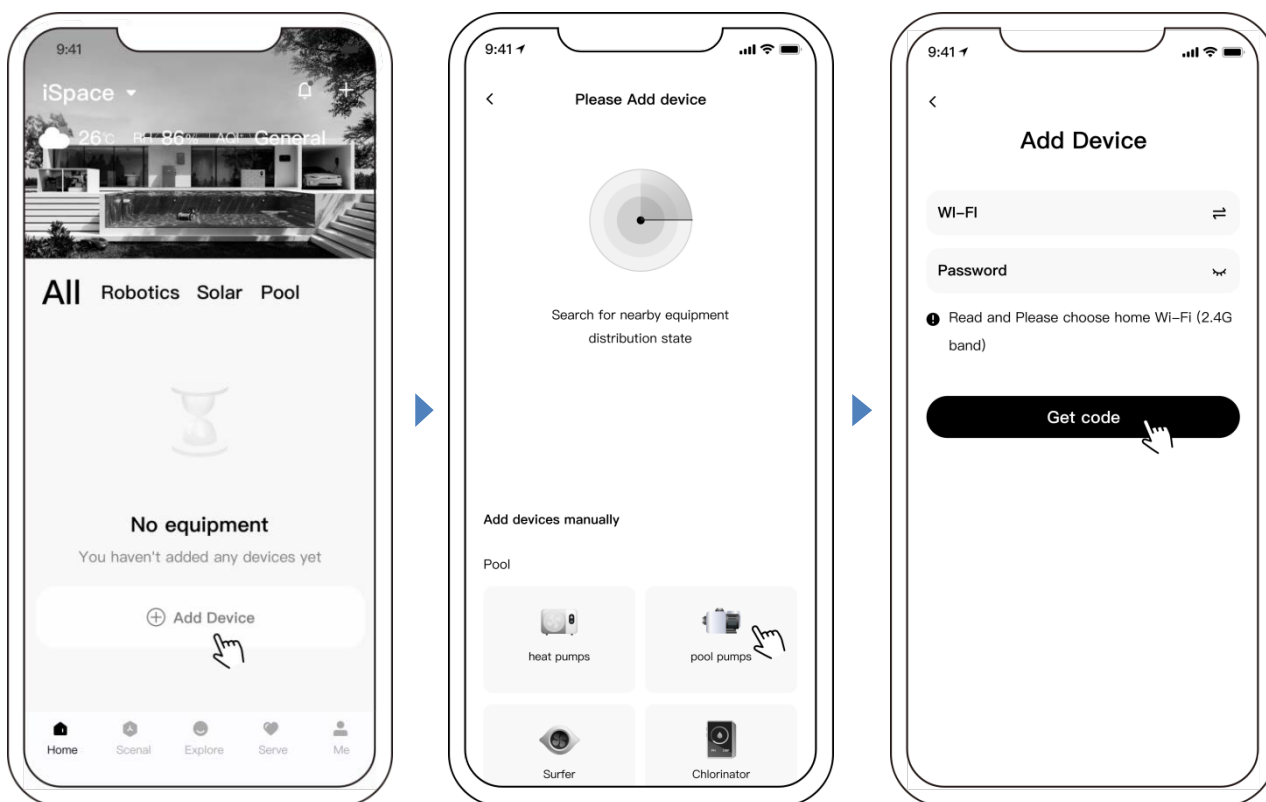

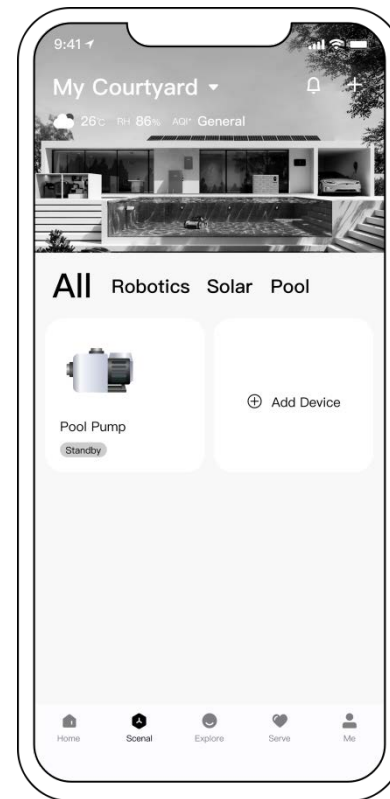
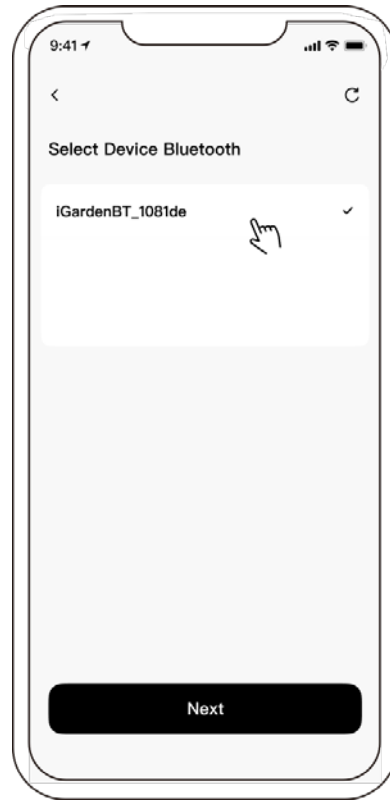
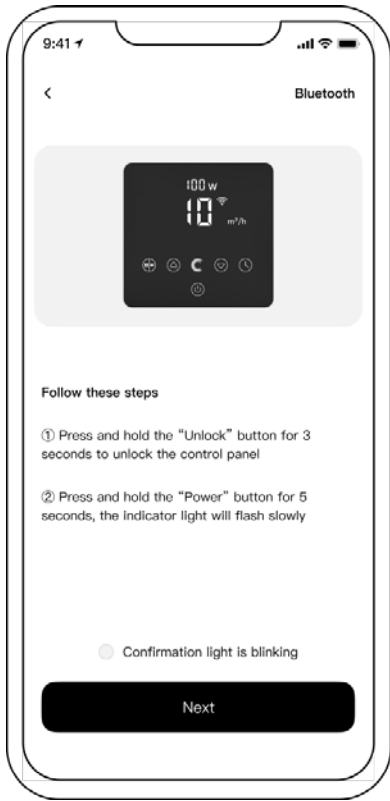

4 Operação

1) Modo Inversor Automático (modo AI):



2) Modo inversor manual (modo MI):

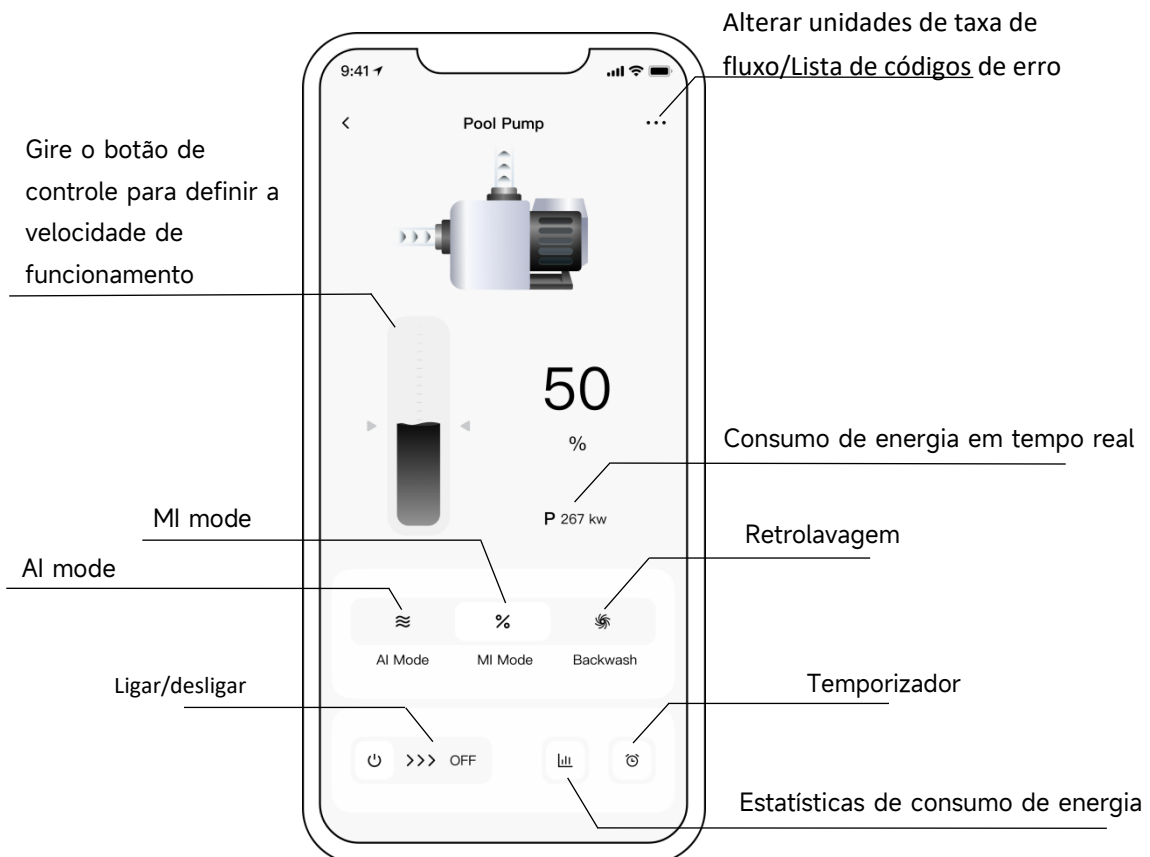

3) Modo de retrolavagem:

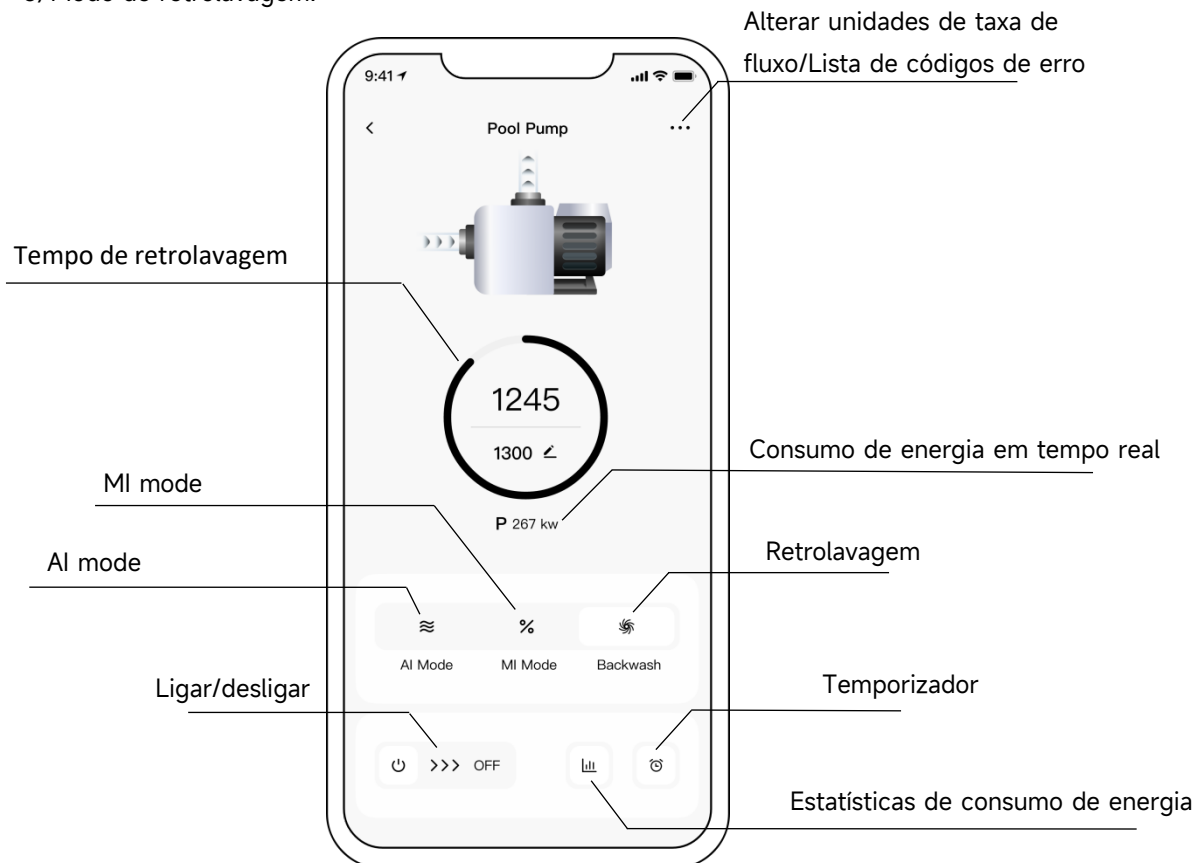

Aviso sobre a configuração do temporizador através do aplicativo:

- 1) A variação temporal é de $\pm 30s$;
- 2) Para evitar conflitos e invalidação de pontos de temporização sobrepostos devido ao atraso da rede, recomenda-se que o horário de término e o horário de início do próximo período de temporização não se sobreponham, e que seja reservado um intervalo de tempo suficiente, por exemplo, de pelo menos 2 minutos;

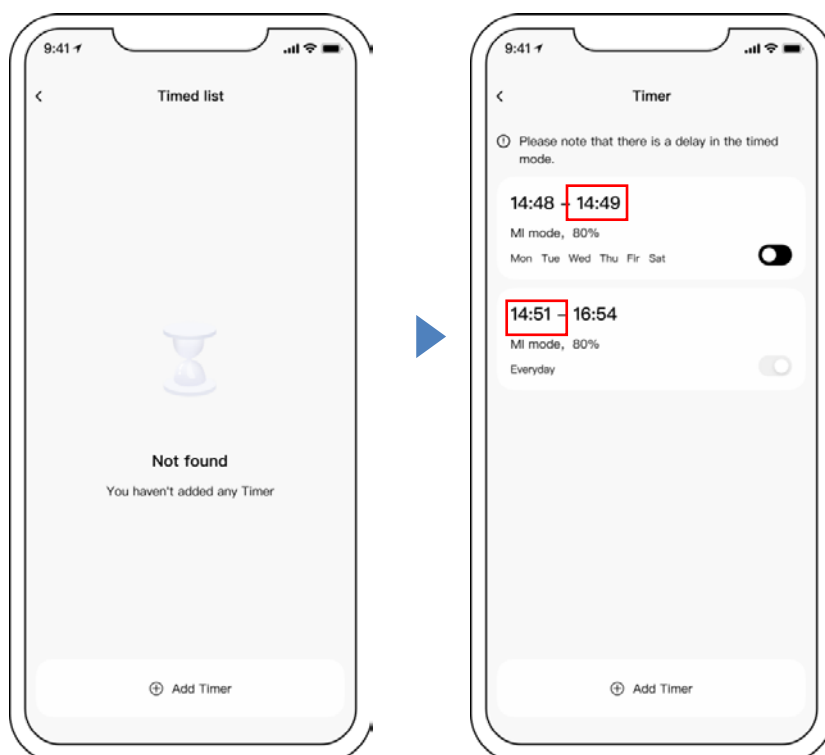

5 Compartilhando dispositivos com seus familiares

Os usuários podem compartilhar os dispositivos para serem controlados por seus familiares. Primeiro, peça aos seus familiares que registrem o “iGarden”. Depois disso, o administrador poderá operar conforme as instruções abaixo:

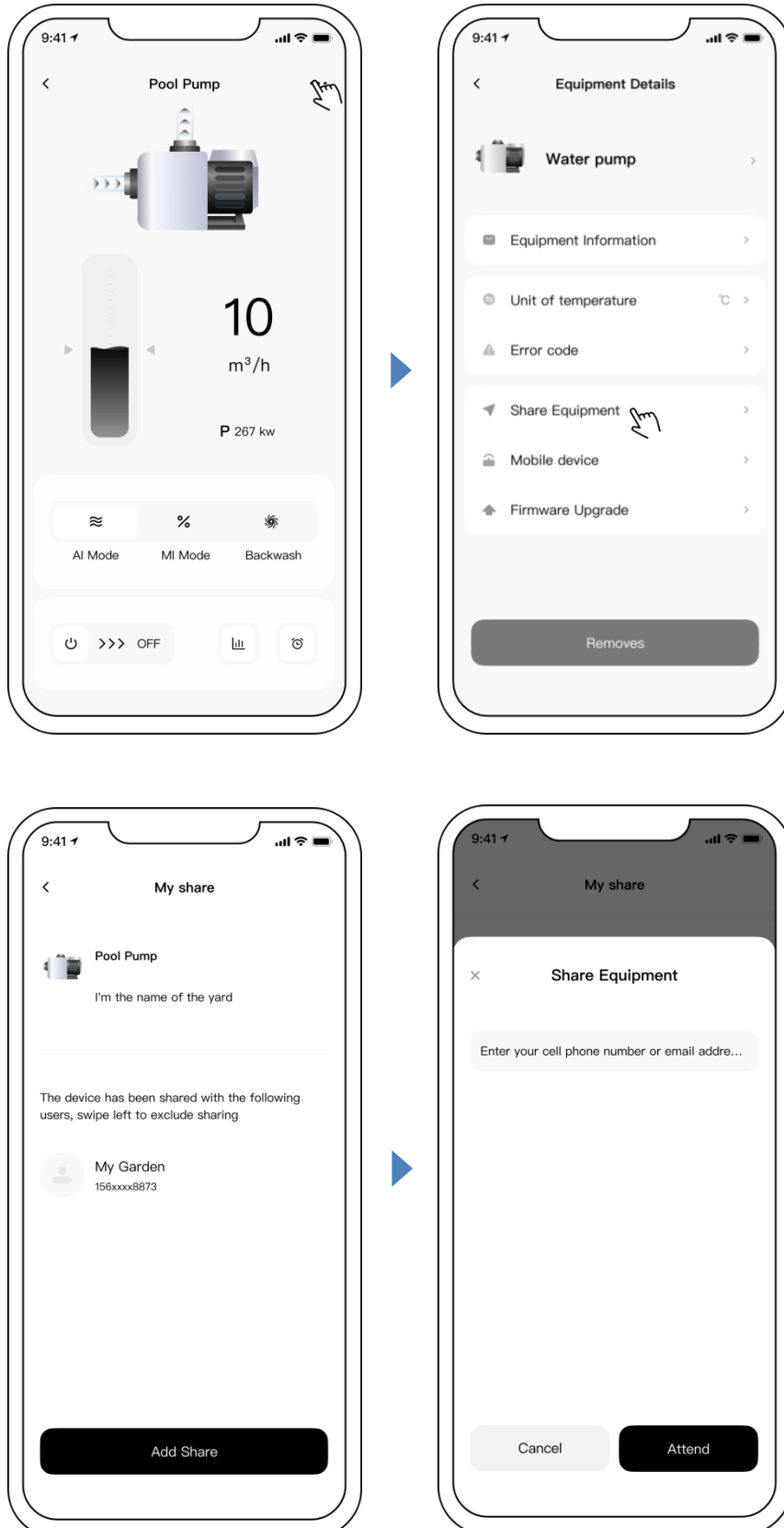

6 Gestão de Jardins

Na lista de dispositivos, o pátio atual é exibido. Após clicar, os usuários podem visualizar/alternar entre todos os pátios atuais, clicar em "Gerenciamento de Jardim" e também acessar a página da lista de pátios. Conforme mostrado abaixo:

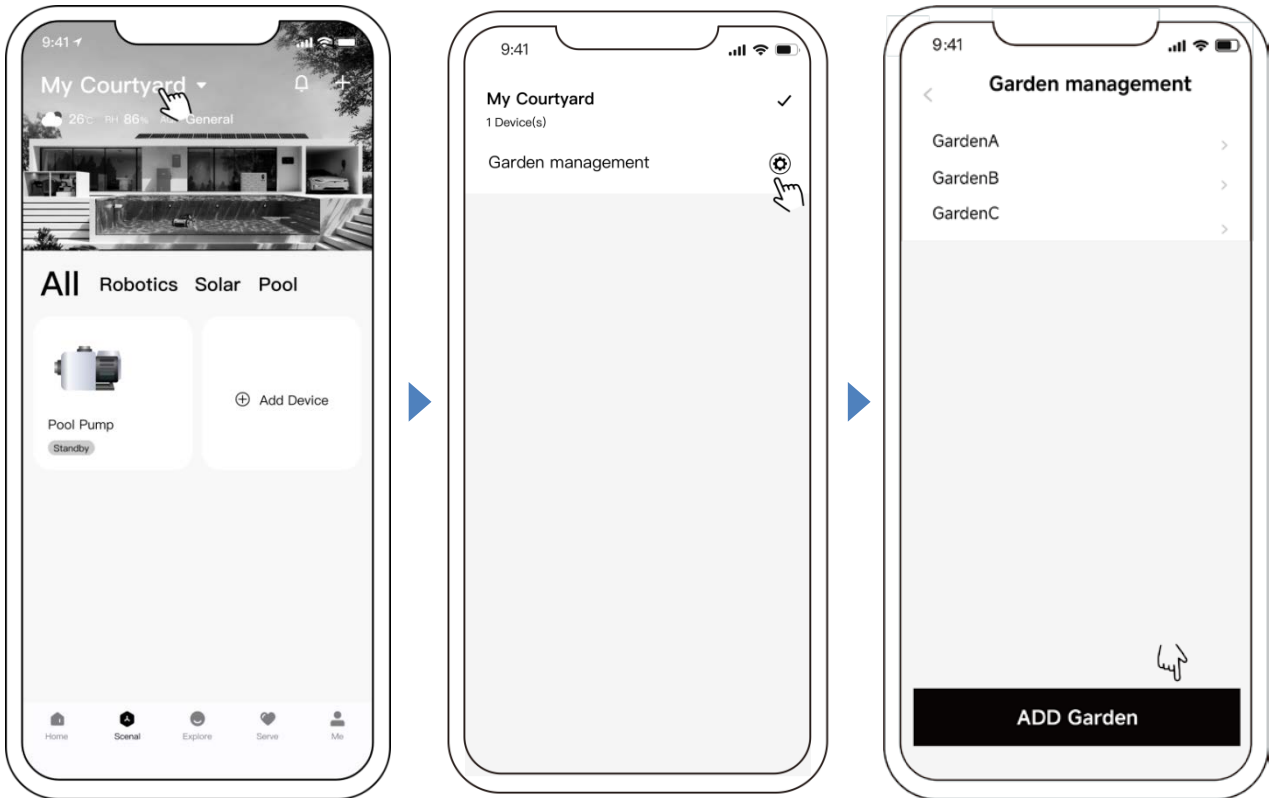

7 Central de mensagens

A: Visualizar mensagem: Na página da lista de dispositivos, clique no ícone de mensagem para acessar a central de mensagens e visualizar a mensagem correspondente, conforme mostrado abaixo: (Incluindo: Alarme, Jardim, Notificação)

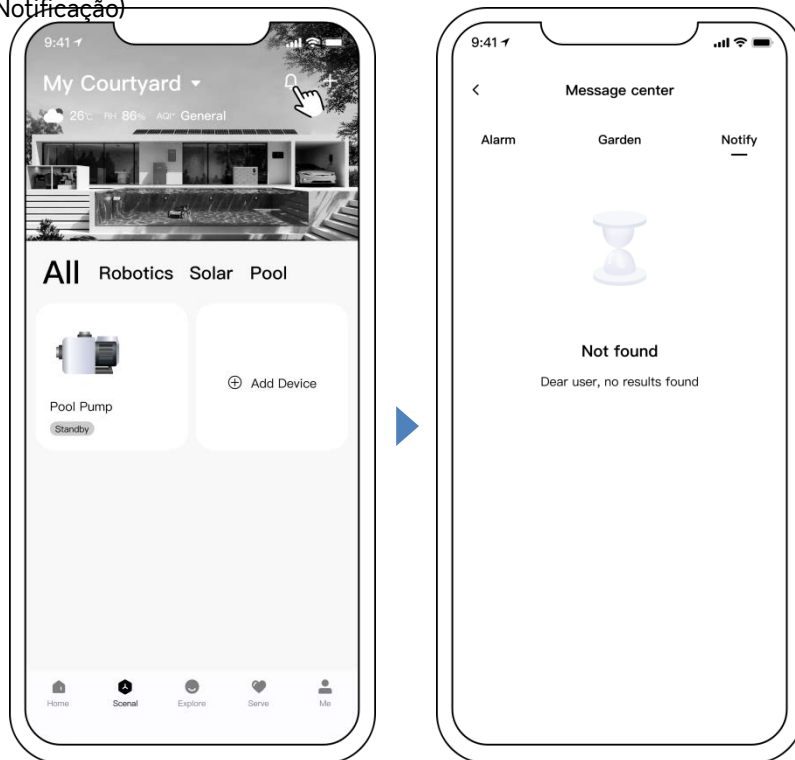

B: Configurações de Push: Na página Configurações, clique em [Configurações de Push] para acessar a página Configurações de Push. Os usuários podem definir as configurações de push de acordo com a classificação da mensagem, conforme mostrado abaixo:

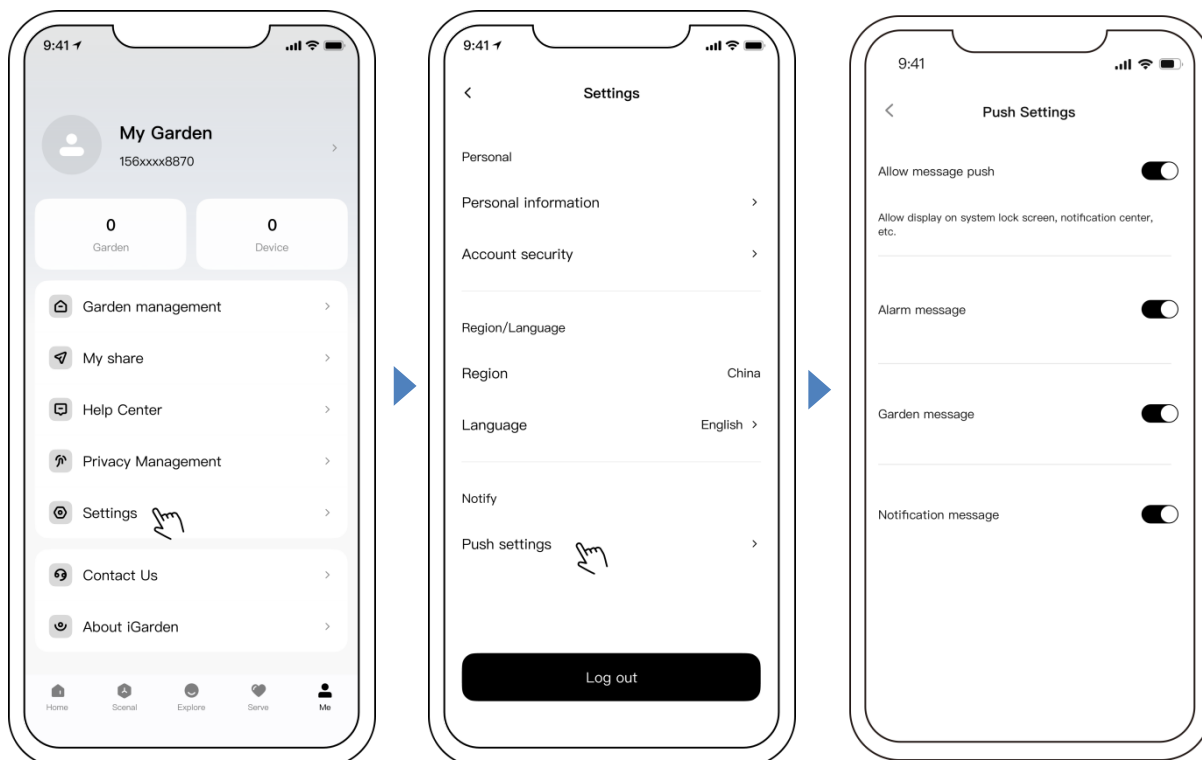

Caso encontre algum problema durante o uso, envie-nos seu feedback. O processo é o seguinte:

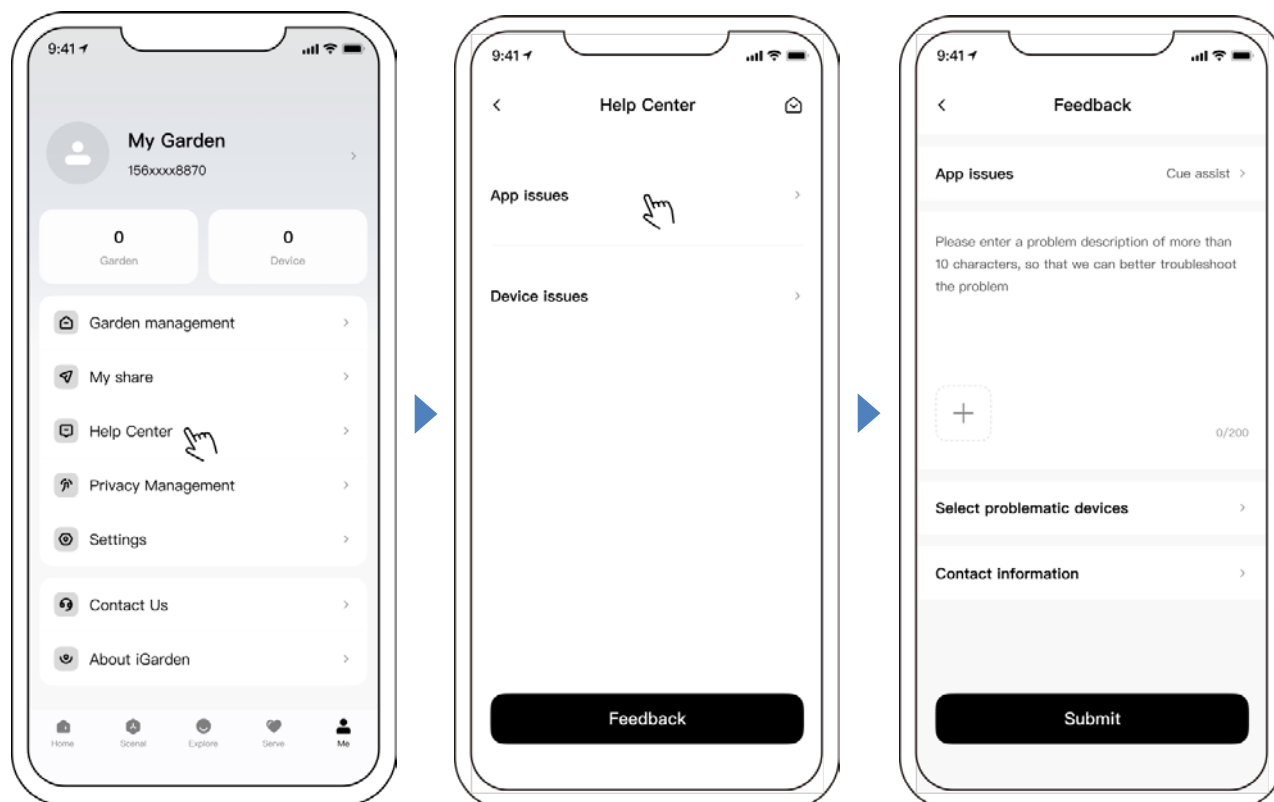

Perceber:

- 1) A previsão do tempo é apenas para referência;
- 2) Os dados de consumo de energia são apenas para referência, pois podem ser afetados por problemas de rede e imprecisão no cálculo;
- 3) aplicativo está sujeito a atualizações sem aviso prévio.

7 CONTROLE EXTERNO

O controle externo pode ser habilitado através dos seguintes contatos. Se mais de um controle externo estiver habilitado, a prioridade será a seguinte: Entrada Digital > RS485 > Controle do Painel.



Figura 5 - Localização da porta do conector



Figura 6 - Conector de entrada digital e RS485

Entrada de alimentação CA (adequada para 115 V e 230 V)

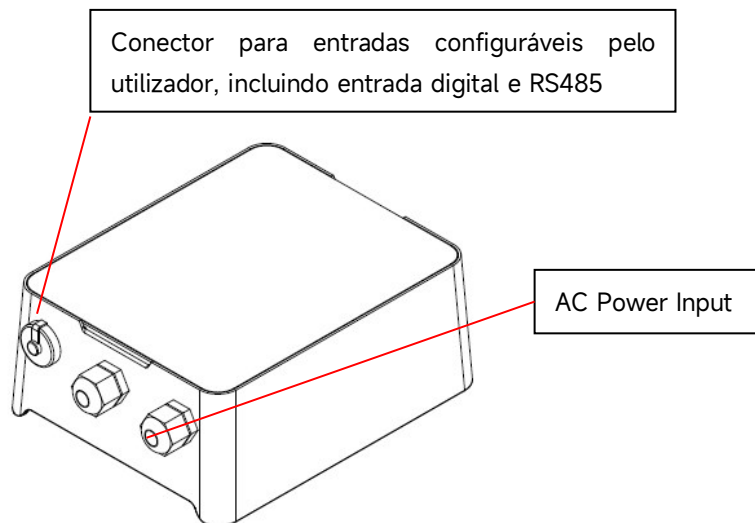

Figura 7 - Ligação do cabo de alimentação

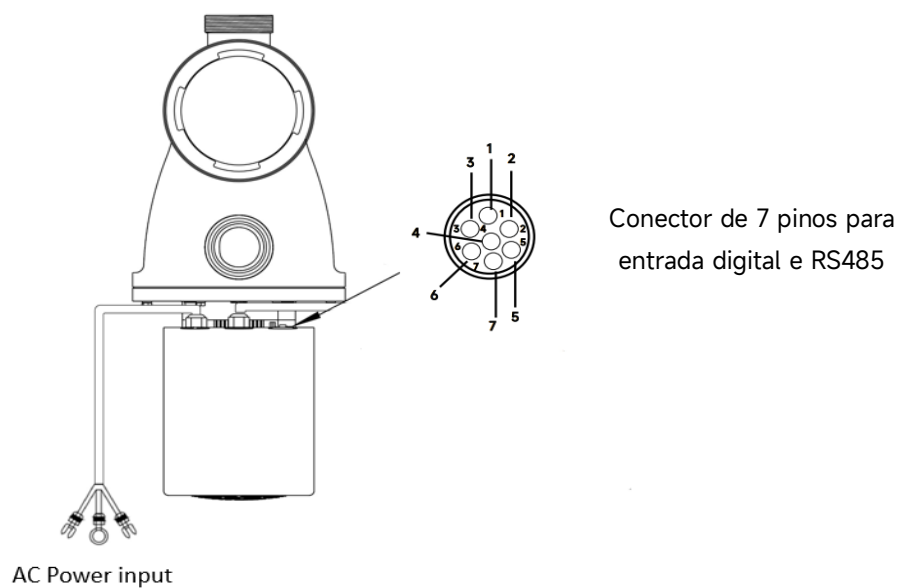
Controle externo	Cor	Descrição	Observação
Entrada digital	Vermelho	Di4 (Entrada Digital 4)	Velocidade padrão = 40%
	Preto	Di3 (Entrada Digital 3)	Velocidade padrão = 80%
	Branco	Di2 (Entrada Digital 2)	Velocidade padrão = 100%
	Cinza	Di1 (Entrada Digital 1)	Parar
	Amarelo	Terra Digital (COM)	COM
RS485	Verde	RS485-A	/
	Marrom	RS485-B	/

a. Entrada digital

A capacidade de execução é determinada pelo estado da entrada digital.

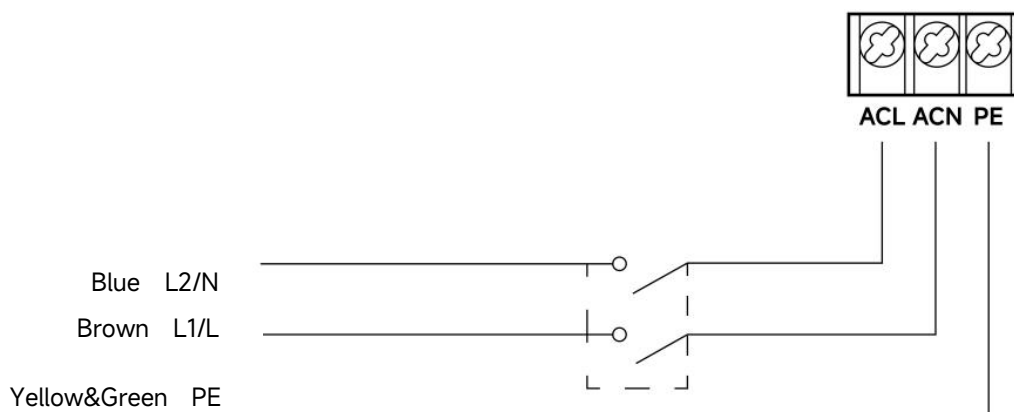
- 1) Quando Di1 (cinza) se conectar com COM (amarelo), a bomba deverá parar obrigatoriamente; se desconectada, o controle digital ficará inválido;
- 2) Quando o fio Di2 (branco) estiver conectado ao fio COM (amarelo), a bomba deverá funcionar obrigatoriamente a 100%; se desconectado, a prioridade de controle retornará ao painel de controle;
- 3) Quando o fio Di3 (preto) estiver conectado ao fio COM (amarelo), a bomba deverá funcionar obrigatoriamente a 80%; se desconectado, a prioridade de controle retornará ao painel de controle;
- 4) Quando o fio Di4 (vermelho) estiver conectado ao fio COM (amarelo), a bomba deverá funcionar obrigatoriamente a 40%; se desconectado, a prioridade de controle retornará ao painel de controle;
- 5) A capacidade das entradas (Di2/Di3/Di4) pode ser modificada de acordo com a configuração dos parâmetros.

b. RS485

Para conectar-se aos cabos RS485-A (verde) e RS485-B (marrom), a bomba pode ser controlada através do protocolo de comunicação Modbus 485.

8 PROTEÇÃO E FALHA

8.1 de Alta Temperatura e Redução de Velocidade - AL01

Em "Auto Inversor/Manual Nos modos "Inverter" e "Temporizador" (exceto retrolavagem/autoescorvamento), quando a temperatura do módulo atinge o limite de alerta de alta temperatura (81 °C), o sistema entra em estado de alerta de alta temperatura ; quando a temperatura cai para o limite de liberação do alerta de alta temperatura (78 °C), o alerta de alta temperatura é liberado. A área de exibição mostra alternadamente AL01 e a velocidade ou vazão de operação .

Se AL01 for exibido, a capacidade de execução será reduzida automaticamente conforme abaixo:

- 1) Se a capacidade operacional atual for superior a 100 %, a capacidade de funcionamento será automaticamente reduzida para 85% ;
- 2) Se a capacidade operacional atual estiver entre 85% e 100%, a capacidade de funcionamento será automaticamente reduzida em 15%;
- 3) Se a capacidade operacional atual estiver entre 70% e 85%, a capacidade de funcionamento será automaticamente reduzida em 10%;
- 4) Se a capacidade operacional atual for inferior a 70%, a capacidade de funcionamento será automaticamente reduzida em 5%.

8.2 Proteção contra subtensão - AL02

entradas de energia CA de 230V e 115V .

① Entrada de alimentação CA: 230 V

Quando o dispositivo detectar que a tensão de entrada é inferior a 198 V, ele limitará a velocidade de operação da corrente. A área de exibição mostrará alternadamente AL02 e a velocidade de operação ou a vazão.

- 1) Quando a tensão de entrada for menor ou igual a 180V, a capacidade de funcionamento será limitada a 70%;
- 2) Quando a tensão de entrada estiver entre 180V e 190V, a capacidade de funcionamento será limitada a 75%;
- 3) Quando a tensão de entrada estiver entre 190V e 198V, a capacidade de operação será limitada a 85% .

② Entrada de alimentação CA: 115 V

Quando o dispositivo detectar que a tensão de entrada é inferior a 98 V, ele limitará a velocidade de operação da corrente. A área de exibição mostrará alternadamente AL02 e a velocidade de operação ou a vazão.

- 3) Quando a tensão de entrada estiver entre 85V e 90V, a capacidade de funcionamento será limitada a 75%;
- 4) Quando a tensão de entrada estiver entre 90V e 98V, a capacidade de operação será limitada a 85% .

Nota: Se a tensão de entrada for inferior a 85 V, será apresentado o código de erro E001 (Tensão de entrada anormal, consulte 8.4).

8.3 Solução de problemas

Problema	Possíveis causas e soluções
A bomba não liga.	<ul style="list-style-type: none"> Falha na fonte de alimentação, fiação desconectada ou defeituosa. Fusíveis queimados ou sobrecarga térmica aberta. Verifique se o eixo do motor gira livremente e se não há obstruções. Devido ao longo período de inatividade, desligue a fonte de alimentação e gire manualmente o eixo traseiro do motor algumas vezes com uma chave de fenda.
A bomba não escorva	<ul style="list-style-type: none"> Esvazie o compartimento da bomba/filtro. Certifique-se de que o compartimento da bomba/filtro esteja cheio de água e que o anel de vedação da tampa esteja limpo. Conexões soltas no lado da sucção. Cesto do filtro ou cesto do skimmer cheio de detritos. Entrada de sucção obstruída. Se a distância entre a entrada da bomba e o nível do líquido for superior a 2 metros, a altura de instalação da bomba deve ser reduzida.
Baixo fluxo de água	<ul style="list-style-type: none"> A bomba não escorva. Entrada de ar na tubulação de sucção. Cesto cheio de detritos. Nível de água inadequado na piscina.
Bomba barulhenta	<ul style="list-style-type: none"> Vazamento de ar na tubulação de sucção, cavitação causada por linha de sucção obstruída ou subdimensionada, vazamento em qualquer junta, nível baixo de água na piscina e linhas de retorno de descarga desobstruídas. Vibração causada por instalação inadequada, etc. Rolamento ou impulsor do motor danificado (é necessário contatar o fornecedor para reparo).

8.4 Código de erro

Quando o dispositivo detectar uma falha, ele irá parar automaticamente e exibir o código de erro . Após 15 segundos parado , verifique se a falha foi corrigida . Se desobstruído, a bomba voltará a funcionar .

Item	Código de erro	Detalhes	
		Descrição	
1	E001	Descrição	Tensão de entrada anormal : A tensão da fonte de alimentação está fora da faixa de 165V a 275V .
		Processo	A bomba irá parar automaticamente por 15 segundos e voltará a funcionar se detectar que a tensão da fonte de alimentação está

			dentro da faixa especificada.
2	E002	Descrição	Sobrecorrente de saída: A corrente de pico da bomba é maior que a corrente de proteção.
		Processo	A bomba irá parar automaticamente por 15 segundos e depois Retome o funcionamento . Se isso ocorrer três vezes seguidas, a bomba desligará e precisará ser verificada . Reiniciado manualmente.
3	E102	Descrição	Dissipador de calor Erro: A temperatura do dissipador de calor atingiu 91 °C por 10 segundos . Ou o sensor do dissipador de calor detectou um circuito aberto ou curto-circuito .
		Processo	1. A bomba irá parar automaticamente por 30 segundos e retomar o funcionamento se detectar que a temperatura do dissipador de calor é inferior a 81 °C. 2. A bomba irá parar automaticamente após 15 segundos. e retomar o funcionamento se detectar que o sensor do dissipador de calor não está aberto ou em curto -circuito .
4	E103	Descrição	na placa controladora principal: O Placa de driver mestre está com defeito.
		Processo	A bomba irá parar automaticamente por 15 segundos e depois Retome o funcionamento . Se isso ocorrer três vezes seguidas, a bomba desligará e precisará ser verificada . Reiniciado manualmente.
5	E104	Descrição	Proteção contra falta de fase: Os cabos do motor não estão conectados à placa de acionamento principal .
		Processo	A bomba irá parar automaticamente por 15 segundos e depois Retome o funcionamento . Se isso ocorrer três vezes seguidas, a bomba desligará e precisará ser verificada . Reiniciado manualmente.
6	E203	Descrição	de leitura de tempo RTC : Leitura e gravação As informações do relógio estão incorretas .
		Processo	O a bomba precisa de ser desligado e reiniciado manualmente.
7	E204	Descrição	Falha na leitura da EEPROM da placa de exibição : Leitura e gravação as informações de A EEPROM da placa de exibição está incorreta .
		Processo	O a bomba precisa de ser desligado e reiniciado manualmente.
8	E205	Descrição	Erro de comunicação : O A falha na comunicação entre a placa de exibição e a placa controladora principal dura 15 segundos.
		Processo	A bomba irá parar automaticamente por 15 segundos. e retomar o

			funcionamento se detectar que a comunicação entre a placa de exibição e a placa controladora principal dura 1 segundo.
9	E207	Descrição	Sem proteção contra água : A bomba está sem água.
		Processo	Desligue a bomba manualmente, encha-a com água e reinicie-a. Se isso ocorrer duas vezes seguidas, a bomba irá desligar e precisará ser verificada manualmente.
10	E209	Descrição	Perda de escorva : A bomba não consegue se autoescorvar devido a motivos como alcance de sucção excessivo ou tubulação muito complexa.
		Processo	Verifique se não há vazamentos na bomba ou na tubulação e, em seguida, encha a bomba com água e reinicie-a.

9 MANUTENÇÃO

Esvazie o cesto do filtro com frequência. O cesto deve ser inspecionado através da tampa transparente e esvaziado quando houver um acúmulo visível de resíduos. As seguintes instruções devem ser seguidas:

- 1) Desconecte a fonte de alimentação.
- 2) Desaperte a tampa do cesto do coador girando-a no sentido anti-horário e remova-a.
- 3) Levante o cesto do coador.
- 4) Esvazie o cesto com os resíduos e enxágue-os, se necessário.

Nota: Não bata a cesta de plástico em uma superfície dura, pois isso pode causar danos.

- 5) Inspeccione a cesta em busca de sinais de danos e substitua-a.
- 6) Verifique se o anel de vedação da tampa apresenta estiramento, rasgos, rachaduras ou qualquer outro dano.
- 7) Recoloque a tampa; apertar com a mão é suficiente.

Nota: Inspeccionar e limpar periodicamente o cesto do filtro ajudará a prolongar sua vida útil.

10 GARANTIA E EXCLUSÕES

Caso seja constatado algum defeito durante o período de garantia, o fabricante, a seu critério, reparará ou substituirá o item ou peça em questão, sem custos para o cliente. Para usufruir dos benefícios da garantia, o cliente deverá seguir o procedimento de solicitação de garantia.

A garantia será anulada em casos de instalação incorreta, operação incorreta, uso inadequado, adulteração ou utilização de peças de reposição não originais.

11 DISPOSIÇÃO



Ao descartar o produto, separe os resíduos como lixo eletrônico ou entregue-os ao sistema de coleta de lixo local.

A coleta seletiva e a reciclagem de equipamentos usados no momento do descarte ajudam a garantir que sejam reciclados de forma a proteger a saúde humana e o meio ambiente.

Entre em contato com a prefeitura local para obter informações sobre onde você pode descartar sua bomba d'água para reciclagem.

INHALT

1. ⚠ WICHTIGE SICHERHEITSHINWEISE	125
2. TECHNISCHE DATEN	126
3. GESAMTABMESSUNGEN (mm)	126
4. INSTALLATION	127
5. EINSTELLUNG UND BEDIENUNG	129
6. WLAN-BETRIEB (OPTIONAL)	139
7. Externe Steuerung	148
8. Schutz und Ausfall	150
9. WARTUNG	153
10. GARANTIE & AUSSCHLÜSSE	154
11. ENTSORGUNG	154

VIELEN DANK, DASS SIE SICH FÜR UNSERE INVERTER-POOLPUMPEN ENTSCIEDEN HABEN.

DIESE BEDIENUNGSANLEITUNG ENTHÄLT WICHTIGE INFORMATIONEN, DIE IHNEN BEIM BETRIEB UND DER WARTUNG DIESES PRODUKTS HELFEN WERDEN.

BITTE LESEN SIE DIE BEDIENUNGSANLEITUNG VOR DER INSTALLATION UND INBETRIEBNAHME SORGFÄLTIG DURCH UND BEWAHREN SIE SIE ZUR SPÄTEREN REFERENZ AUF.

1. WICHTIGE SICHERHEITSHINWEISE

Bei der Installation und Verwendung dieser elektrischen Geräte sollten stets grundlegende Sicherheitsvorkehrungen getroffen werden, einschließlich der folgenden:

- 1) LESEN UND BEFOLGEN SIE ALLE ANWEISUNGEN
- 2) WARNUNG – Um das Verletzungsrisiko zu verringern, dürfen Kinder dieses Produkt nur unter ständiger Aufsicht benutzen.
- 3) WARNUNG – Gefahr eines Stromschlags. Schließen Sie das Gerät nur an einen Stromkreis an, der durch einen Fehlerstromschutzschalter (RCD) mit einem Nennfehlerstrom von maximal 30 mA geschützt ist. Wenden Sie sich an einen qualifizierten Elektriker, wenn Sie nicht überprüfen können, ob der Stromkreis durch einen Fehlerstromschutzschalter (RCD) geschützt ist.
- 4) UM DIE GEFAHR EINES STROMSCHLAGS ZU VERHINDERN, schließen Sie bitte das Erdungskabel am Motor (grün/gelb) an das Erdungssystem an.
- 5) WARNUNG – Um das Risiko eines Stromschlags zu verringern, ersetzen Sie das beschädigte Kabel sofort.
- 6) Nicht innerhalb einer Außenverkleidung oder unterhalb der Verkleidung eines Whirlpools oder Spas installieren.
- 7) Ein Trennschalter muss gemäß den Installationsvorschriften an der festen elektrischen Anlage angebracht werden.
- 8) Zur Verwendung mit Schwimmbädern, Whirlpools und Spas.
- 9) VORSICHT: Um das Risiko eines Stromschlags zu verringern, installieren Sie das Gerät mindestens 1,8 Meter von den Innenwänden des Pools entfernt. Verwenden Sie kein Verlängerungskabel.
- 10) VORSICHT: Um den Schutz vor Stromschlaggefahr weiterhin zu gewährleisten, verwenden Sie bei Wartungsarbeiten ausschließlich identische Ersatzteile .
- 11) Diese Pumpe ist für fest installierte eingelassene oder Aufstellbecken geeignet und kann auch in Whirlpools und Spas mit einer Wassertemperatur unter 50 °C verwendet werden . Aufgrund der festen Installationsmethode wird die Verwendung dieser Pumpe in Aufstellbecken, die zur Lagerung leicht demontiert werden können, nicht empfohlen.
- 12) Die Pumpe ist nicht tauchfähig
- 13) Öffnen Sie niemals das Innere des Antriebsmotorgehäuses
- 14) BEWAHREN SIE DIESE ANWEISUNGEN AUF.

WARNUNG:

- Pumpe vor Inbetriebnahme mit Wasser füllen. Pumpe nicht trockenlaufen lassen. Bei Trockenlauf wird die Gleitringdichtung beschädigt und die Pumpe beginnt zu lecken.
- Vor Wartungsarbeiten an der Pumpe muss die Stromzufuhr zur Pumpe unterbrochen werden, indem der Hauptstromkreis der Pumpe getrennt wird, und der gesamte Druck aus der Pumpe und dem Rohrleitungssystem muss abgelassen werden.
- Schrauben dürfen niemals festgezogen oder gelöst werden, während die Pumpe in Betrieb ist.
- Stellen Sie sicher, dass Ein- und Auslass der Pumpe frei von Fremdkörpern sind.

2. HNISCHE DATEN

Modell	Empfohlenes Poolvolumen (m ³)	P1	Spannung (V/Hz)	Qmax (m ³ /h)	Hmax (m)	Zirkulation (m ³ /h)	
		KW				Bei 10 m	Bei 8 m
DCP12-IG	40-70	1.2	220-240/ 50/60	28.0	21.0	23.0	26.0

3. GESAMTABMESSUNGEN (mm)



Abbildung 1 – Pumpenabmessungen

4. INSTALLATION

4.1 Pumpenstandort

- 1) Installieren Sie die Pumpe so nah wie möglich am Pool, um Reibungsverluste zu reduzieren und die Effizienz zu verbessern. Verwenden Sie kurze, direkte Saug- und Rücklaufleitungen.
- 2) Um direkte Sonneneinstrahlung, Hitze oder Regen zu vermeiden, wird empfohlen, die Pumpe im Innenbereich oder im Schatten aufzustellen.
- 3) Installieren Sie die Pumpe NICHT an einem feuchten oder schlecht belüfteten Ort. Halten Sie Pumpe und Motor mindestens 150 mm von Hindernissen entfernt, da Pumpenmotoren zur Kühlung eine freie Luftzirkulation benötigen.
- 4) Die Pumpe sollte waagrecht installiert und mit Schrauben in der Öffnung der Halterung befestigt werden, um unnötige Geräusche und Vibrationen zu vermeiden.

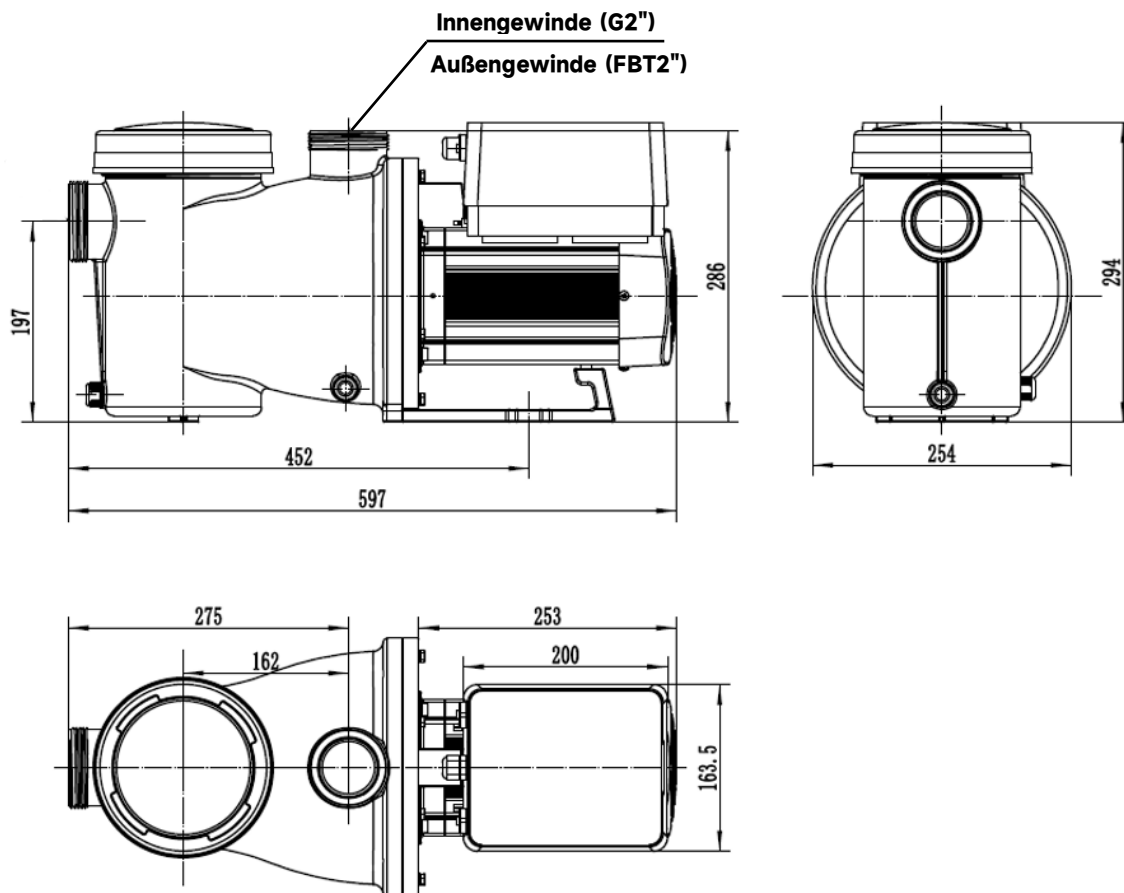
4.2 Sanitärinstallationen und Ventile

- 1) Die Größe der Pumpeneinlass-/auslassverschraubung: wahlweise metrisch (50 oder 63 mm) oder imperial (1,5 " oder 2") .
- 2) Zur Optimierung der Poolverrohrung sollte ein Rohr mit größerem Durchmesser verwendet werden. Es wird empfohlen, ein Rohr mit einem Durchmesser von 63mm.
- 3) Bei der Montage der Einlass- und Auslassarmaturen (Verbindungen) mit der Rohrleitung ist das spezielle Dichtmittel für PVC-Material zu verwenden.
- 4) Die Dimension der Saugleitung sollte gleich oder größer als der Durchmesser der Einlassleitung sein, um zu vermeiden, dass die Pumpe Luft ansaugt, was die Effizienz der Pumpe beeinträchtigen würde.
- 5) Um Reibungsverluste zu reduzieren und die Effizienz zu verbessern, sollten die Rohrleitungen auf der Saug- und Rücklaufseite kurz und direkt sein.
- 6) Bei gefluteten Saugsystemen sollten sowohl in der Saug- als auch in der Rücklaufleitung der Pumpe Ventile installiert sein, was die routinemäßige Wartung erleichtert. Ein in der Saugleitung installiertes Ventil, ein Winkelstück oder ein T-Stück sollte mindestens das Siebenfache des Saugleitungsdurchmessers vom Pumpenausgang entfernt sein.
- 7) , sollte in der Rücklaufleitung ein Rückschlagventil eingesetzt werden , wenn zwischen der Rücklaufleitung und dem Pumpenauslass ein signifikanter Höhenunterschied besteht .

4.3 Armaturen

- 1) Rohrbögen sollten mindestens 350 mm vom Einlass entfernt sein. 90°-Rohrbögen dürfen nicht direkt in den Pumpeneinlass/-auslass eingebaut werden. Die Verbindungen müssen dicht sein.
- 2) Die Verbindungen müssen fest sein.



Abbildung 2 – Installation von Rohrleitungen und Armaturen

* Die Größe der Pumpeneinlass-/auslassverschraubung: optional metrisch (50 oder 63 mm) oder imperial (1,5 " oder 2")

3. Verwenden Sie das vom Pumpenhersteller mitgelieferte Verbindungsset (siehe Abbildung 3). Verwenden Sie keine anderen Verbindungsstücke für den Pumpenein-/auslass, da diese nicht zusammenpassen und das Pumpengehäuse beschädigen könnten.

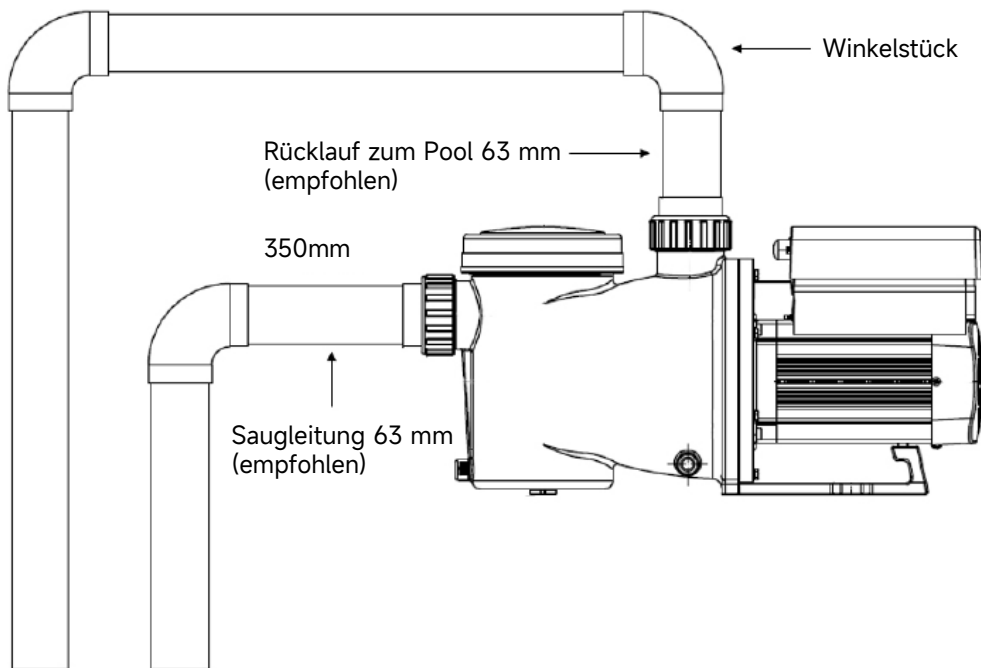

Abbildung 3 – Verbindungs-Kit

4.4 Vor dem ersten Start prüfen





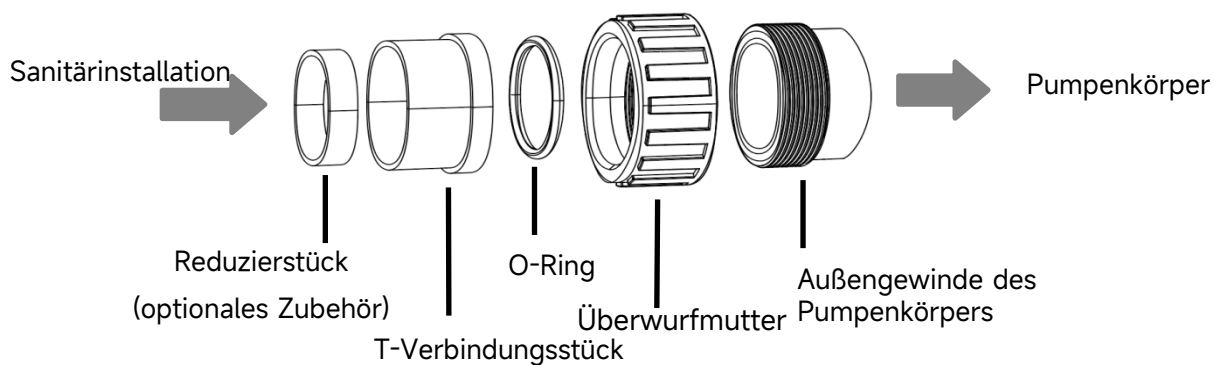

- 1) Prüfen Sie, ob sich die Pumpenwelle frei dreht;
- 2) Prüfen Sie, ob die Spannung und Frequenz der Stromversorgung den Angaben auf dem Typenschild entsprechen;
- 3) Wenn man vor dem Lüfterflügel steht, sollte die Drehrichtung des Motors im Uhrzeigersinn sein;
- 4) Es ist verboten, die Pumpe ohne Wasser zu betreiben.

4.5 Anwendungsbedingungen

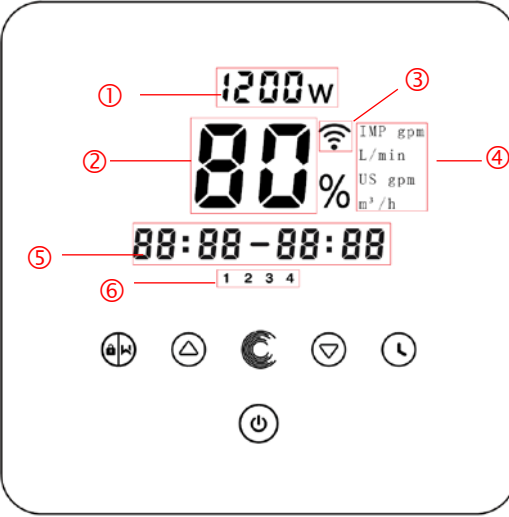
Umgebungstemperatur	Aufstellung im Innenbereich, Temperaturbereich: -10-42°C
Maximale Wassertemperatur	50°C
Salzwasser verfügbar	Salzkonzentration bis zu 3,5 %, d. h. 35 g/l
Luftfeuchtigkeit	≤90% relative Luftfeuchtigkeit, (20°C±2°C)
Installation	Die Pumpe kann maximal 2 m über dem Wasserspiegel installiert werden.
Schutz	Schutzklasse F, IP55

5 EINSTELLUNG UND BETRIEB



5.1 Anzeige auf dem Bedienfeld

	① Stromverbrauch
	② Betriebskapazität / Durchflussrate
	③ WLAN-Anzeige (optional)
	④ Durchflusseinheit
	⑤ Timerperiode
	⑥ Timer 1/2/3/4
	 Rückspülung/Entriegelung
	 Hoch/Runter: zum Ändern des Einstellungswerts
	 Wechseln Sie zwischen manuellem Modus Wechselrichtermodus und Auto Wechselrichtermodus. Handbuch Wechselrichtermodus : Die Betriebskapazität wird manuell zwischen 30% und 120 % eingestellt. Auto Inverter-Modus : Die Betriebskapazität wird automatisch zwischen 30 % und 120 % entsprechend der voreingestellten Durchflussrate angepasst. Der Standardmodus ist Handbuch Wechselrichter Modus.
	 Timer-Einstellung
 Ein/Aus	

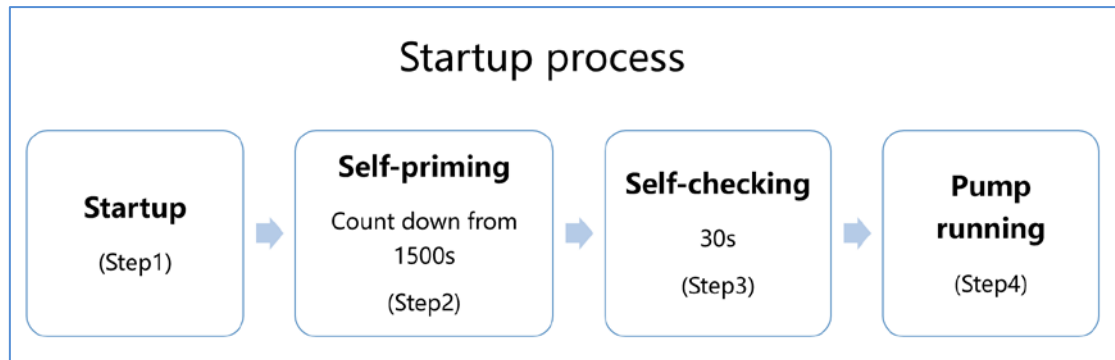
5.2 Start-up Verfahren Übersicht



① Schritt 1 : Startvorgang

- Zum Entsperren des Bildschirms länger als 3 Sekunden gedrückt halten .
- Drücken  Zu Start-up Die Pumpe.

② Schritt 2 : Selbstpriming

- Der Pumpe wird beginnen Der Countdown beginnt bei 1500 Sekunden ; sobald das System erkennt, dass die Pumpe mit Wasser gefüllt ist, stoppt es den Countdown und beendet den Ansaugvorgang automatisch.
- Benutzer können die Parametereinstellung aufrufen , um die standardmäßige Selbstansaugfunktion zu deaktivieren (siehe 5.11) .



③ Schritt 3 : Selbstprüfung

- Der Pumpe wird erneut 30 Sekunden lang prüfen, ob die Selbstansaugung (Schritt 2) abgeschlossen ist .

④ Schritt 4 : Pumpe läuft

- Die Pumpe läuft beim ersten Anlauf nach dem Selbstansaugen mit 80 % ihrer Nennleistung .

5.3 Start-up

Wenn das Gerät eingeschaltet wird, wird der Bildschirm Wenn die LED 3 Sekunden lang vollständig aufleuchtet , wird der Gerätecode angezeigt und das Gerät wechselt anschließend in den normalen Betriebszustand. Im gesperrten Zustand leuchtet nur die LED. Taste  Die Anzeige leuchtet auf.  Zum Entsperren des Bildschirms länger als 3 Sekunden gedrückt halten . Der Bildschirm sperrt sich automatisch nach einer Minute Inaktivität und die Helligkeit wird auf ein Drittel der normalen Anzeige  reduziert . Durch kurzes Drücken wird der Bildschirm aktiviert und die relevanten Betriebsparameter angezeigt.

5.4 Selbstansaugend

Bei jedem Start der Pumpe beginnt die Selbstansaugung .

Wenn die Pumpe funktioniert Selbstansaugend, zählt es herunter. Der Countdown startet automatisch von 1500 Sekunden und stoppt, sobald das System erkennt, dass die Pumpe mit Wasser gefüllt ist. Anschließend überprüft das System erneut 30 Sekunden lang , ob die Selbstansaugung abgeschlossen ist .



Der Benutzer kann den Selbstansaugvorgang manuell durch Drücken einer Taste  abbrechen . bei einer Dauer von mehr als 3 Sekunden schaltet die Pumpe beim ersten Start in den standardmäßigen manuellen Invertermodus .

Bemerkung:

Die Pumpe wird mit aktivierter Selbstansaugfunktion geliefert. Bei jedem Neustart der Pumpe wird die Selbstansaugfunktion automatisch ausgeführt. Benutzer können die Parametereinstellungen aufrufen , um die standardmäßige Selbstansaugfunktion zu deaktivieren (siehe 5.11) .

5.5 Rückströmung











Der Benutzer kann die Rückspülung oder die schnelle Umwälzung in jedem Betriebszustand durch Drücken der Taste starten .

	Standard	Einstellbereich
Zeit	180er	Drücken Sie die Taste  oder ,  um von 0 bis 1500 Sekunden einzustellen, wobei jeder Schritt 30 Sekunden dauert.
Betriebskapazität	100%	60-1 0 0%, Parametereinstellung eingeben (siehe 5.11)

Austrittsrückströmung :

Wenn der Rückspülmodus aktiviert ist, kann er durch 3-sekündiges Gedrückthalten der Taste  werden. Die Pumpe kehrt dann in den Zustand vor dem Rückspülvorgang zurück . Falls vom Benutzer eine Drehzahlbegrenzung festgelegt wurde, darf die Förderleistung im Rückspülmodus diese Begrenzung nicht überschreiten (siehe Abschnitt 5.10) .

5.6 Handbuch Wechselrichtermodus













1		Halten Sie die Taste  länger als 3 Sekunden gedrückt, um den Bildschirm zu entsperren .
2		drücken  . Die Pumpe läuft nach dem Selbstansaugen beim ersten Start mit 80 % ihrer Nennleistung.
3	 	Drücken Sie die Taste  oder ,  um die Laufleistung zwischen 30% und 120% in 5%-Schritten einzustellen .
4		Drücken Sie  erneut, um in den Auto-Inverter-Modus zu wechseln.

Notiz :

- 1) Bei hohem Leitungsdruck kann die Betriebskapazität auf 105–120 % eingestellt werden, um eine ausreichende Fördermenge zu gewährleisten . Die Pumpe läuft dann mit höherer Drehzahl, um dem hohen Leitungsdruck entgegenzuwirken.
- 2) Im Bereich von 105% bis 120% der Nennleistung passt die Pumpe die Drehzahl automatisch an, sobald sie die maximale Leistung erreicht hat.
- 3) Wenn der Benutzer beispielsweise die Geschwindigkeit auf 110 % einstellt, wenn die Pumpe Die Leistung hat bei dieser Drehzahl ihren Maximalwert erreicht . Selbst wenn der Benutzer die Pumpendrehzahl weiter auf 120 % erhöht , hält die Pumpe die Drehzahl bei maximaler Leistung, also 110 % , aufrecht. Die angezeigte Drehzahl sinkt dabei von 120 % auf 110 %.

5.7 Auto Wechselrichtermodus

erkennt die Pumpe automatisch den Systemdruck und passt die Motordrehzahl an, um den eingestellten Durchfluss zu erreichen.

1		Entsperren Sie den Bildschirm und drücken Sie die entsprechende Taste,  um vom manuellen Wechselrichtermodus in den automatischen Wechselrichtermodus zu wechseln.
2	 	Die Durchflussrate konnte durch Drücken von  oder  mit 1 m ³ /h angepasst werden.
3	 	Die Einheit der Durchflussrate kann durch Drücken beider Tasten in l  /min , iMP gpm oder US gpm geändert werden.  für 3 Sekunden .
4		Drücken Sie diese Taste  , um in den manuellen Wechselrichtermodus zu wechseln .

Der standardmäßige einstellbare Durchflussbereich für InverK ist wie folgt :

Modell	Ein einstellbarer Durchflussbereich*
DCP12-IG	8-25 m ³ /h

*** Notiz :**





Im Auto-Inverter-Modus basiert die maximal einstellbare Durchflussrate auf einer Förderhöhe von ca. 8 m.







Wenn der Benutzer den Durchfluss auf die maximal einstellbare Durchflussrate einstellt und der Rohrleitungsdruck höher als 8 m ist, erhöht die Pumpe in dieser Situation automatisch die Drehzahl und die Eingangsleistung, um dem hohen Druck entgegenzuwirken und die vom Benutzer eingestellte maximale Durchflussrate aufrechtzuerhalten.

Wenn die Motordrehzahl und die Eingangsleistung auf den Maximalwert ansteigen, dies aber nicht ausreicht, um dem enormen Rohrleitungsdruck entgegenzuwirken, sinkt der auf dem Pumpenregler angezeigte Durchfluss vom Sollwert auf den tatsächlich erreichbaren Durchfluss .

5.8 Timer-Modus

Die Ein-/Ausschalt- und Betriebskapazität der Pumpe könnte durch eine Timer, der bei Bedarf täglich programmiert werden kann.

1	Timer-Einstellungen durch Drücken aufrufen 
2	Drücken Sie die Taste  oder ,  um die Ortszeit einzustellen.
3	Drücken Sie  zum Bestätigen und wechseln Sie zur Zeit-1-Einstellung.



4	Drücken  oder  um die gewünschten Laufzeiten , die Betriebskapazität oder den Durchfluss auszuwählen (Wenn das %-Symbol blinkt, können Benutzer die Durchflussrate durch Drücken der entsprechenden Taste einstellen )
5	 Wiederholen Sie die obigen Schritte, um die Einstellungen vorzunehmen. andere 3 Timer
6	 Halten Sie die Taste 3 Sekunden lang gedrückt, um die Einstellung zu speichern und den Timer-Modus zu aktivieren.
7	 Oder  überprüfen Sie 4 Timer, um sicherzustellen, dass keine ungültige Einstellung vorliegt.



Notiz:

- 1) Wenn der eingestellte Zeitraum die aktuelle Zeit enthält, startet die Pumpe entsprechend der eingestellten Förderleistung oder Durchflussrate , angezeigt durch die aktuelle Timeranzeige.  (1 oder 2 oder 3 oder 4) leuchtet auf, und der Bereich **88:88-88:88** wird den entsprechenden Zeitraum anzeigen .
- 2) Wenn der eingestellte Zeitraum die aktuelle Zeit nicht enthält, wird die Timernummer verwendet.  (1 oder 2 oder 3 oder 4), das/die gleich losläuft, wird angezeigt und blinkt , und der Bereich **88:88-88:88** wird den entsprechenden Zeitraum anzeigen .
- 3) Während der Timer-Einstellung: Wenn Sie zur vorherigen Einstellung zurückkehren möchten, halten Sie beide Tasten gedrückt.   Halten Sie die Taste 3 Sekunden lang gedrückt. Wenn Sie nicht alle 4 Timer einstellen müssen, können Sie  die Taste 3 Sekunden lang gedrückt halten. Das System speichert dann automatisch den aktuell eingestellten Wert und aktiviert den Timer-Modus.
- 4) Die Timer - Einstellungen der Pumpe sind begrenzt, die Benutzer werden keine sich überschneidenden Timer einstellen.
- 5) Nachdem der Timer eingestellt wurde und die Pumpe anschließend vom Benutzer ausgeschaltet wird, kehrt sie beim erneuten Einschalten wieder in den Timer-Modus zurück.
- 6) Benutzer können den Timer-Modus durch Drücken einer Taste abbrechen .  Die

5.9 Skimmer Modus

Der Skimmermodus ermöglicht es der Pumpe, die Wasseroberfläche abzusaugen, verhindert die Ansammlung von Schmutz und sorgt so für einen saubereren Pool.

Halten Sie die Taste  gedrückt,  um die voreingestellte Benutzeroberfläche des Skimmer-Modus aufzurufen. Beim erstmaligen Wechsel in diesen Modus wird die Voreinstellung 1 aktiviert.

Durch Drücken der Taste  oder  können die 4 Voreinstellungen angezeigt werden. Die Details der einzelnen Voreinstellungen sind wie folgt: Die ausgewählte Voreinstellung wird nach 5 Sekunden ohne Bedienung aktiviert.

Preset	SKimmer-Zyklus	SKimmer Dauer	Skimmer-Geschwindigkeit	Zeitraum	Anmerkung
1	1 Stunde	3 Minuten	100%	7:00 – 21:00 Uhr	Bearbeitbar in Parametereinstellung
2	1 Stunde	10 Minuten	100%	7:00 – 21:00 Uhr	Nicht bearbeitbar
3	3 Stunden	3 Minuten	80%	7:00 – 21:00 Uhr	Nicht bearbeitbar
4	Den Skimmermodus ausschalten				Nicht bearbeitbar

Tabelle 1 – Voreinstellungen des Skimmer-Modus

Während der Skimmer-Dauer zeigt der Controller die Parameter der Voreinstellung an, die der Benutzer halten kann.  Die Abschäumdauer wird jedes Mal für 3 Sekunden abgebrochen. Nach Ablauf der Abschäumdauer kehrt die Pumpe in den Normalbetrieb zurück und kann vom Benutzer bedient werden.

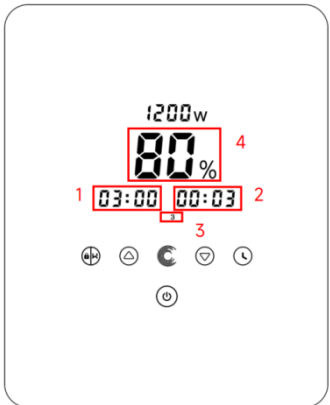
	<ol style="list-style-type: none"> 1. Skimmerzyklus (Stunde) 2. Skimmer-Dauer (Minuten) 3. Skimmer-Modus-Voreinstellungsnummer 4. Skimmergeschwindigkeit / Durchflussrate
---	---



Abbildung 4 – Skimmer-Zyklus

5.10 Geschwindigkeits- / Durchflussbegrenzung

Der Benutzer kann die Drehzahl- /Durchflussbegrenzung der Pumpe so einstellen , dass sie den Durchflussbedarf anderer Geräte wie z. B. Sandfilter erfüllt.



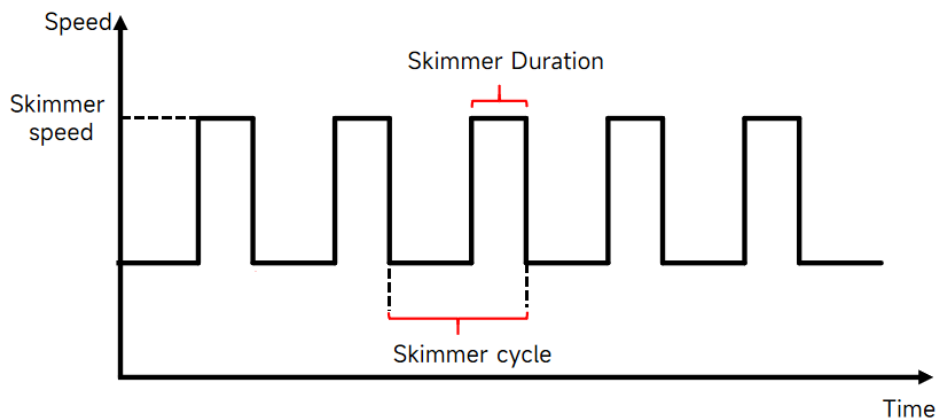

Die Drehzahl- / Durchflussbegrenzung der Pumpe kann in den Parametereinstellungen festgelegt werden. (siehe 5.11)

100 % bedeutet, dass es keine Geschwindigkeitsbegrenzung gibt und die Laufleistung im Normalbetrieb zwischen 30 % und 120 % eingestellt werden kann.

Modell	Geschwindigkeits-/Durchflussbegrenzung	
	Maximale Laufgeschwindigkeit	Maximale Durchflussrate
DCP12-IG	60 % bis 100 %	15-25 m ³ /h



Um die Leistung zu gewährleisten, wird der Selbstansaugprozess bei jedem Startvorgang durchgeführt . wird nicht durch die Geschwindigkeits- /Durchflussbegrenzungsfunktion eingeschränkt .

5.11 Parametereinstellung

Werkseinstellungen wiederherstellen	Schalten Sie die Pumpe aus und halten Sie dann beides gedrückt.  für 3 Sekunden
Überprüfen Sie die Softwareversion	Schalten Sie die Pumpe aus und halten Sie dann beides gedrückt.  für 3 Sekunden
Geben Sie die Parametereinstellungen wie folgt ein:	Schalten Sie die Pumpe aus und halten Sie dann beides gedrückt.  für 3 Sekunden; Presse  Um die Parameteradresse auszuwählen, drücken Sie die

	entsprechende Taste   um die Parametereinstellung anzupassen.
--	---

Parameter Adresse	Beschreibung	Standardeinstellung	Einstellbereich
1	Di2 (Digitaler Eingang 2)	Geschwindigkeit: 100 %	Geschwindigkeit: 30-120%, in 5%-Schritten ; Durchfluss: um 1 m ³ /h Schritte; DCP12-IG: 8-25 m ³ /h Hinweis : Drücken  Zu Zum Ablauf wechseln Rate Einstellung .
2	Di3 (Digitaler Eingang 3)	Geschwindigkeit: 80 %	
3	Di4 (Digitaler Eingang 4)	Geschwindigkeit: 40 %	
4	Rückströmung	Geschwindigkeit: 100 %	Geschwindigkeit: 60-100% , in 5%-Schritten; Durchfluss: um 1 m ³ /h Schritte; DCP12-IG: 8-25 m ³ /h Hinweis : Drücken  Zu Zum Ablauf wechseln Rate Einstellung.
5	Steuermodus des Analogeingangs	0	0 : Stromsteuerung 1: Spannungsregelung
6	Selbstansaugen bei jedem Startvorgang aktivieren oder deaktivieren	25	25: ermöglicht 0: deaktiviert
7	Reserviert	0	Nicht bearbeitbar
8	Systemzeit	00:00	0:00 - 23:59



9	Prsetzt 1 des Skimmermodus zurück	Skimmer-Zyklus : 01:00 Skimmer Dauer : 00:03 Skimmergeschwindigkeit: 100 %	*SKimmerzyklus: 1 - 24 Stunden, 1 Stunde pro Schritt ; *Skimmer Dauer: 1 - 30 Minuten, 1 Minute pro Schritt ; *SKimmergeschwindigkeit: 30%-100%, in 5%-Schritten; *SKimmer-Durchfluss: um 1 m ³ /h Schritte; DCP12-IG: 8-25 m ³ /h Hinweis : Drücken  Zu Zum Ablauf wechseln Rate Einstellung.
10	Zeitdauer der Voreinstellung 1 des Skimmer-Modus	7:00 - 21:00 Uhr	Startzeit: 00:00 - 24:00 Endzeit: 00:00-24:00
11	Geschwindigkeitsbegrenzung	Geschwindigkeit: 100 %	Geschwindigkeit : 60 % - 100 %, in 5%-Schritten; (100 % bedeutet keine Geschwindigkeitsbegrenzung) Durchfluss : um 1 m ³ /h Schritte; DCP12-IG: 15-25 m ³ /h Hinweis : Drücken  Zu Zum Ablauf wechseln Rate Einstellung .
12	RS485	170(0xAA)	160-190 (0xA0-0xBF), jeden Schritt um 1.
13	Reserviert	0	Nicht bearbeitbar

Zum Beispiel: So aktivieren / Selbstansaugfunktion deaktivieren?

- 1) **Parametereinstellungen eingeben:** Schalten Sie die Pumpe aus und halten Sie dann beide Tasten gedrückt

  für 3 Sekunden;

- 2) **Parameteradresse auswählen:** Drücken Sie diese Taste , um Adresse 6 auszuwählen ;

- 3) Selbstansaugfunktion aktivieren oder deaktivieren : Durch Drücken von oder  anpassen , 2 5=
Aktiviert, 0= Deaktiviert .

6 WLAN-BETRIEB (OPTIONAL)

- 1 iGarden-App herunterladen
- 2 Konto registrieren



Android



iOS

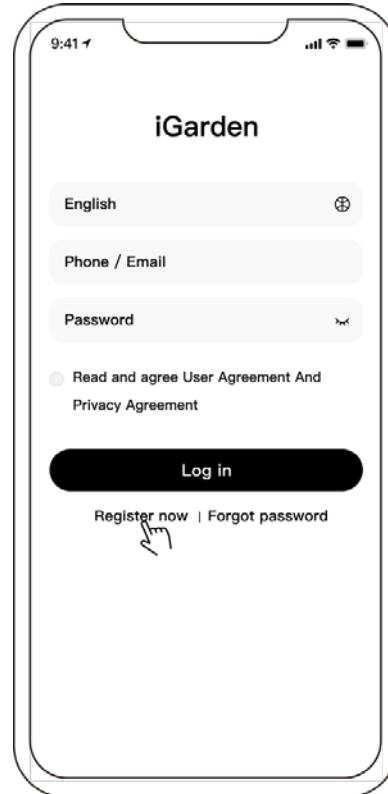

Telefon-/E-Mail-Registrierung

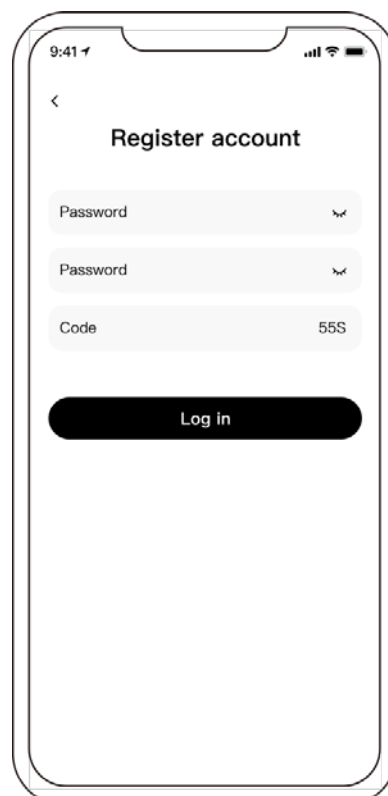
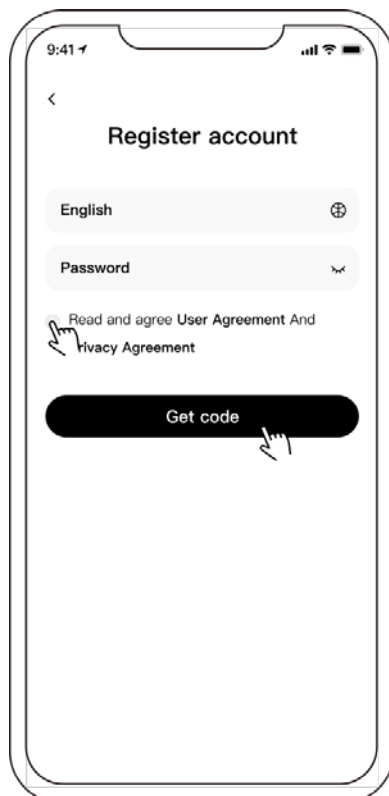

3 App -Kopplung

Bitte vergewissern Sie sich, dass Ihre Pumpe eingeschaltet ist, bevor Sie beginnen.

(Netzwerkbedingungen: 2,4 GHz; 2,4 GHz und 5 GHz werden zu einer SSID zusammengefasst; es gibt jedoch kein separates 5-GHz-Netzwerk)

1) Bitte vergewissern Sie sich, dass Ihr Telefon mit WLAN verbunden und Bluetooth auf Ihrem Telefon eingeschaltet ist.

2) drücken . Nach dem Einschalten der Pumpe  5 Sekunden lang drücken, bis ein Piepton ertönt, und dann loslassen.  Die Anzeige blinkt.

3) Klicken Sie auf „Gerät hinzufügen“ und folgen Sie dann den Anweisungen, um das Gerät zu koppeln.

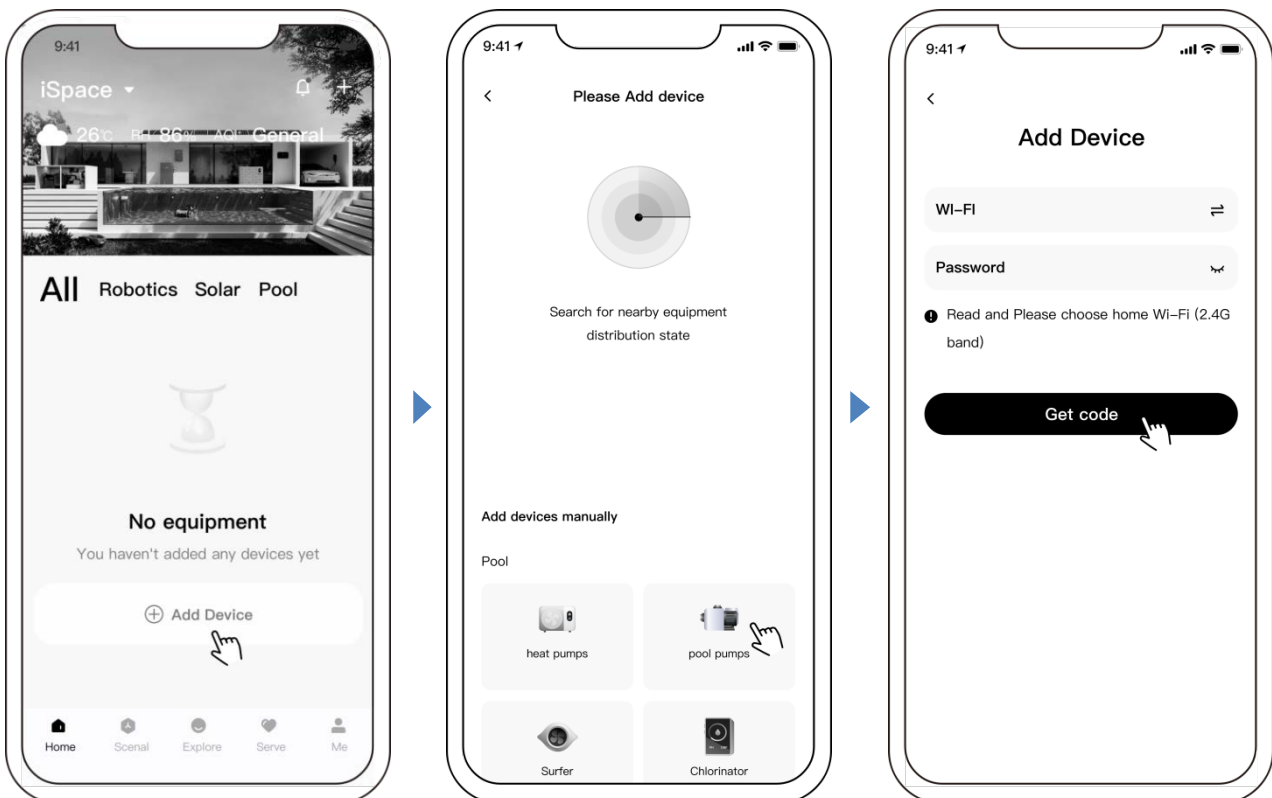

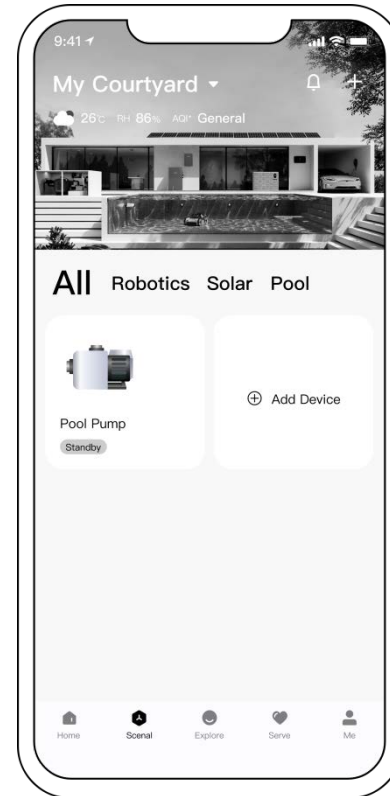
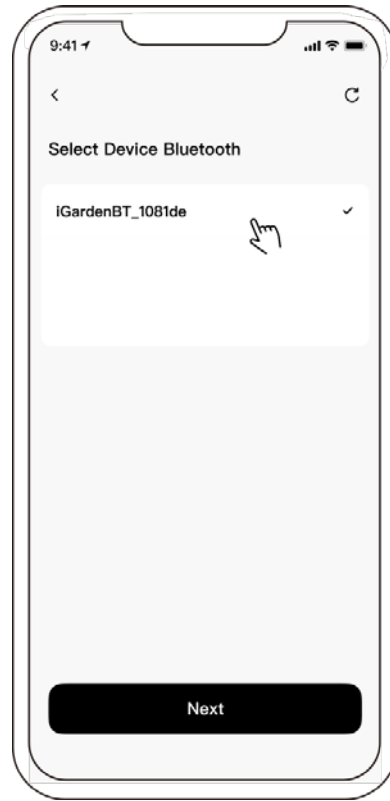
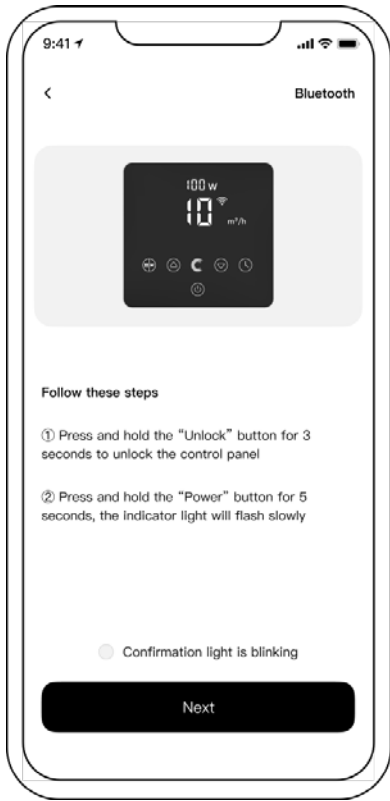

4 Betrieb

1) Auto-Inverter-Modus (AI-Modus):

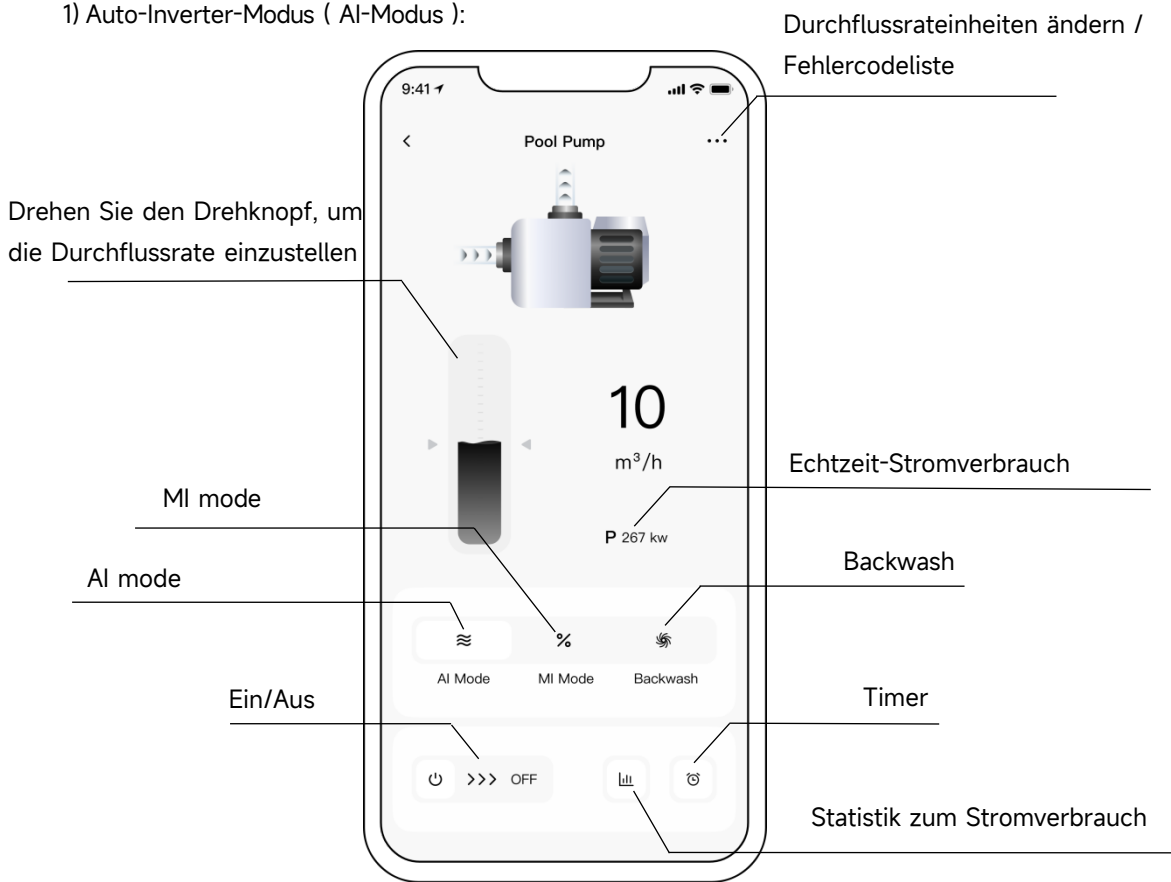

2) Manueller Wechselrichtermodus (MI-Modus):

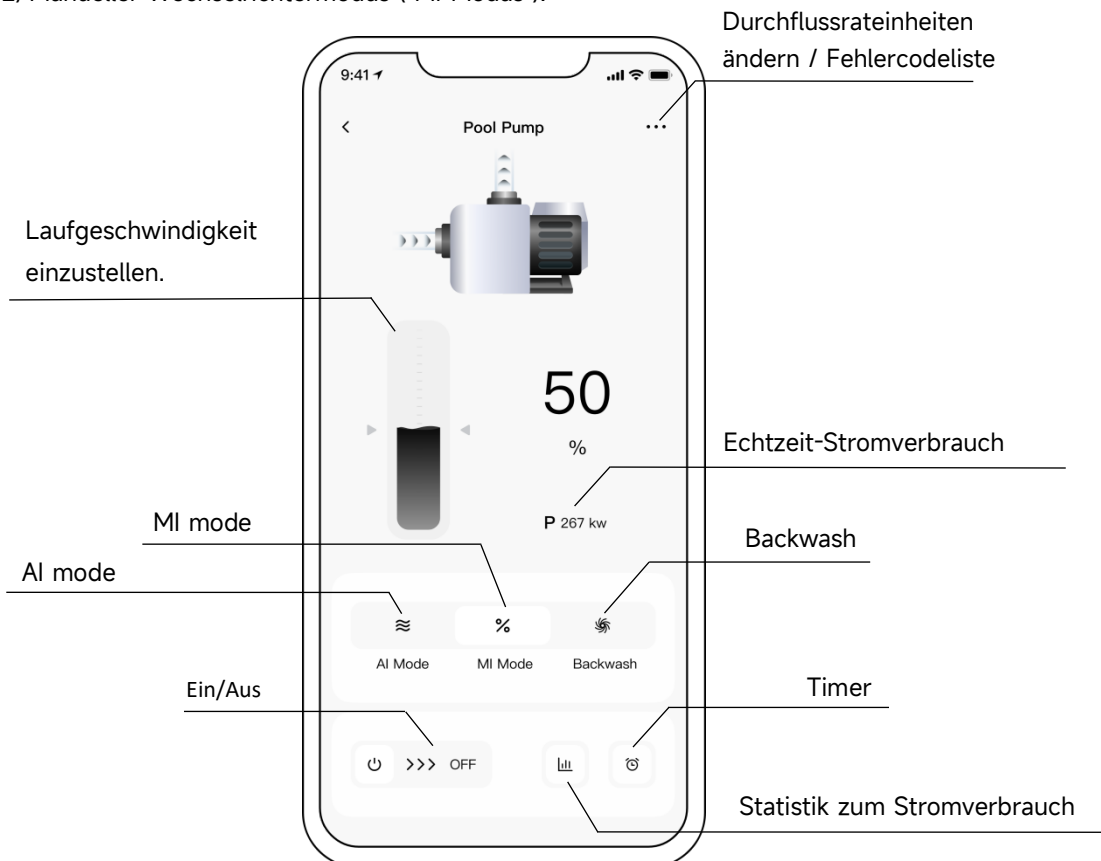

3) Rückspülmodus:

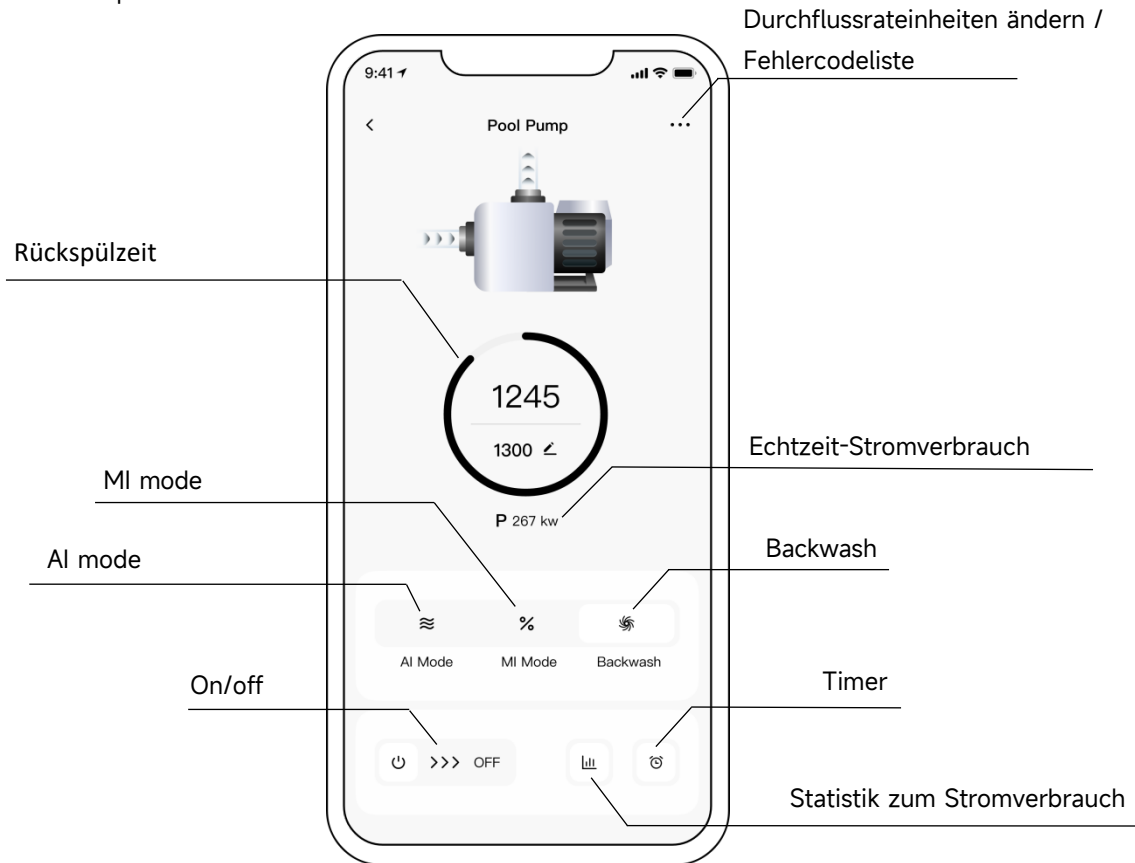

Hinweis zur Timer-Einstellung über die App:

- 1) Die Zeitabweichung beträgt $\pm 30s$;
- 2) Um zu vermeiden, dass sich überlappende Zeitpunkte aufgrund von Netzwerkverzögerungen überschneiden und ungültig werden, wird empfohlen, dass sich die Endzeit und die Startzeit des nächsten Zeitintervalls nicht überschneiden und ein ausreichendes Zeitintervall reserviert wird, zum Beispiel mindestens 2 Minuten;

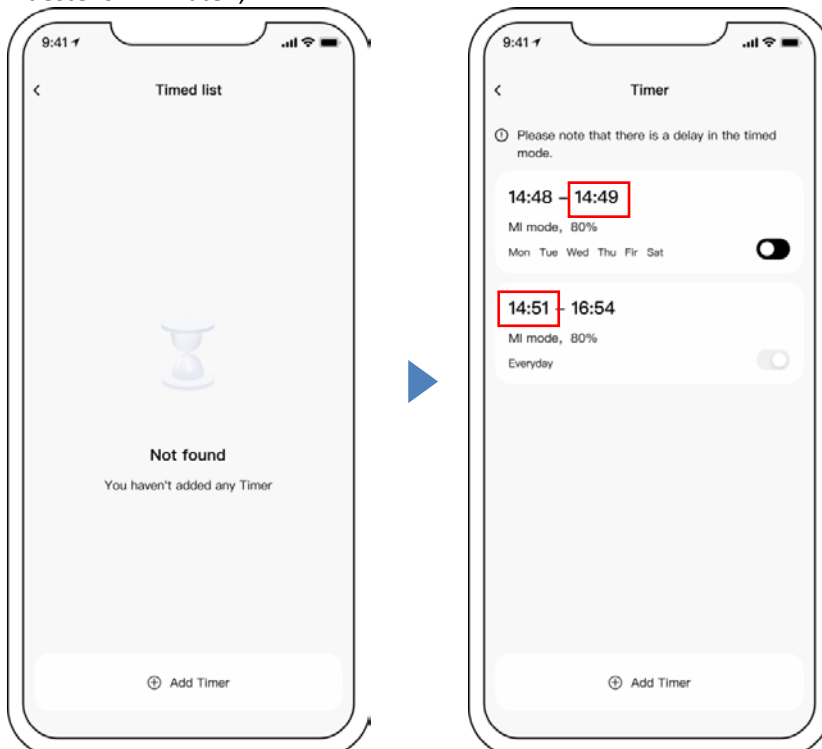

5 Geräte mit Familienmitgliedern teilen

Nutzer können die Geräte mit ihren Familienmitgliedern teilen, damit diese sie steuern können. Bitte lassen Sie Ihre Familienmitglieder sich zuerst bei „iGarden“ registrieren. Anschließend kann der Administrator wie folgt vorgehen:

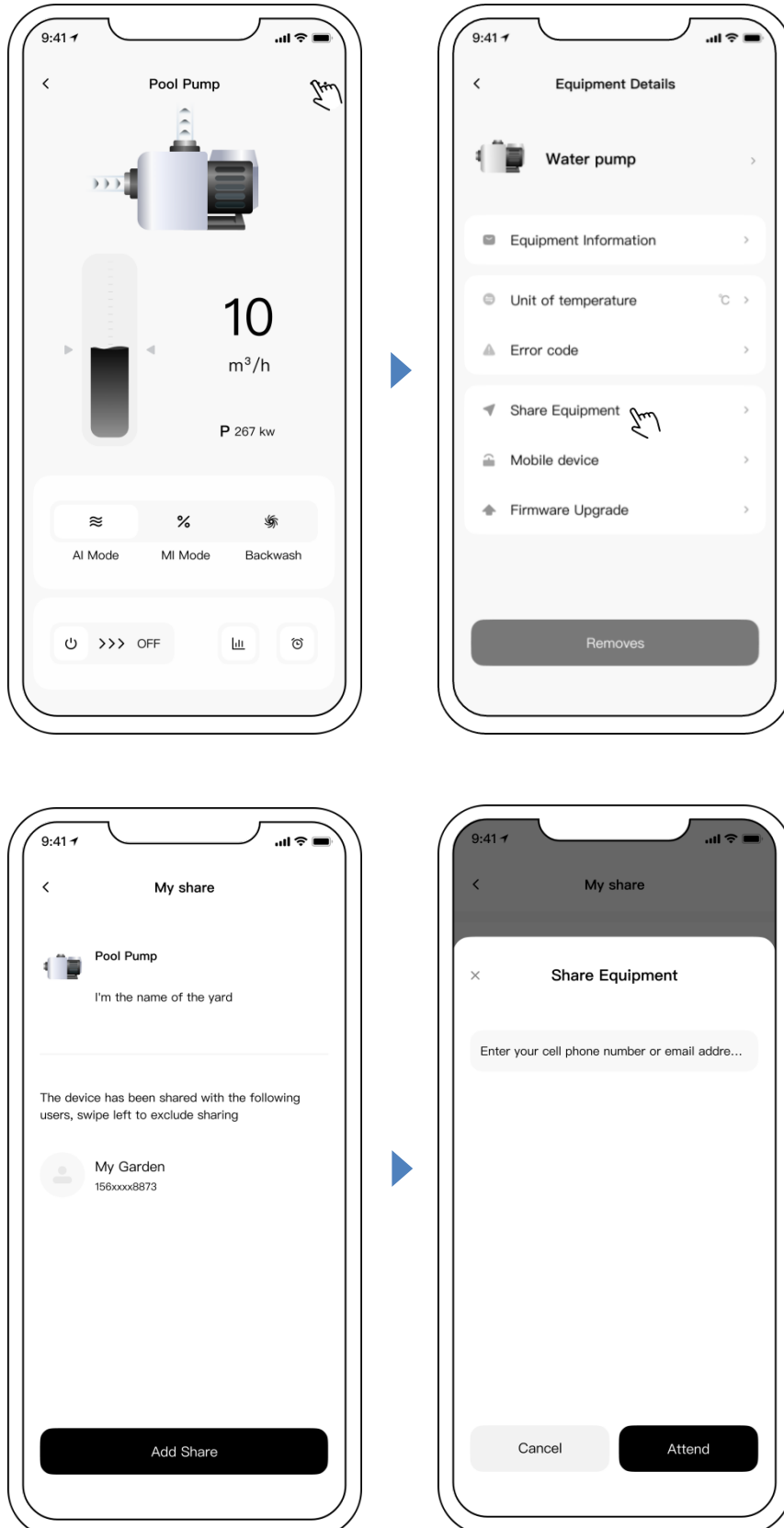

6 Gartenmanagement

In der Geräteliste wird der aktuelle Innenhof angezeigt. Nach dem Anklicken können Benutzer alle aktuellen Innenhöfe anzeigen/zu ihnen wechseln, auf „Gartenverwaltung“ klicken und auch die Seite mit der Innenhofliste aufrufen. Wie unten dargestellt:

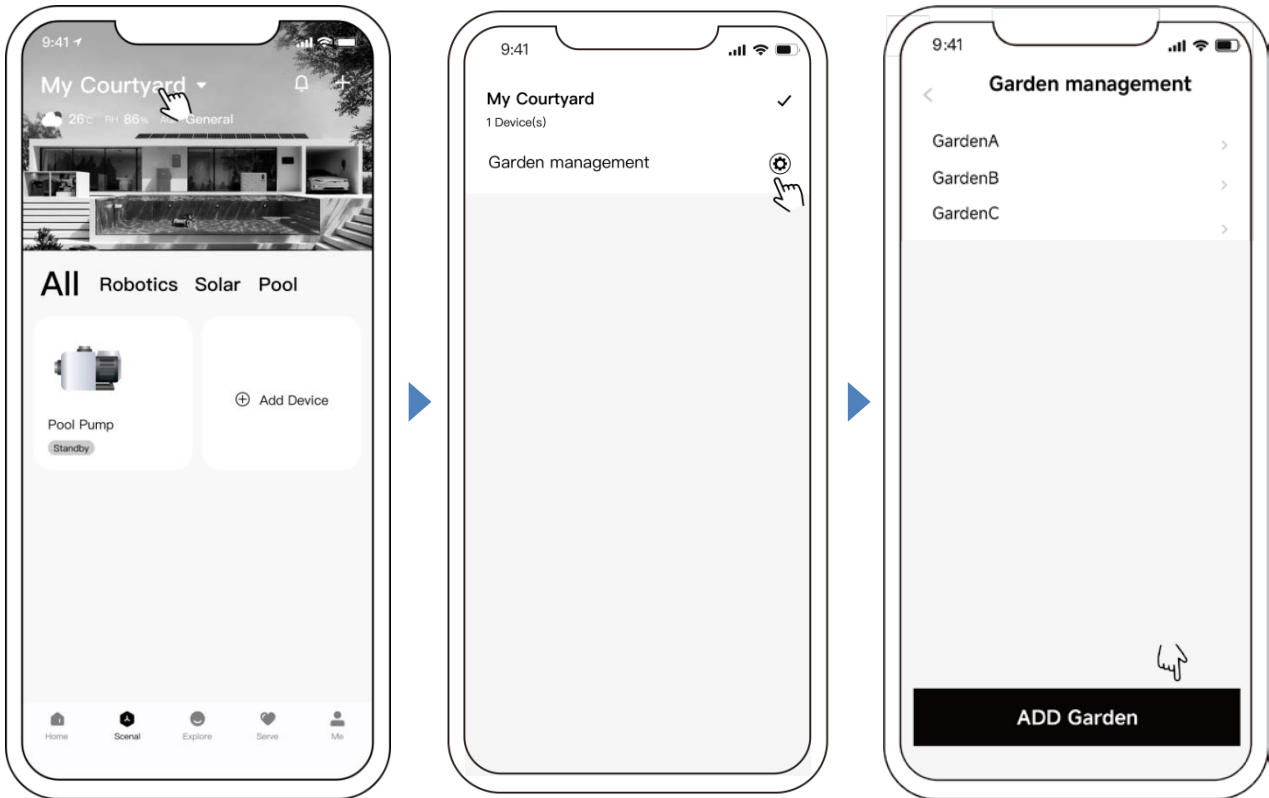

7 Nachrichtenzentrale

A: Nachricht anzeigen: Klicken Sie auf der Gerätelisteiseite auf das Nachrichtensymbol, um das Nachrichtencenter zu öffnen und die entsprechende Nachricht anzuzeigen, wie unten dargestellt: (Einschließlich: Alarm, Garten, Benachrichtigung)

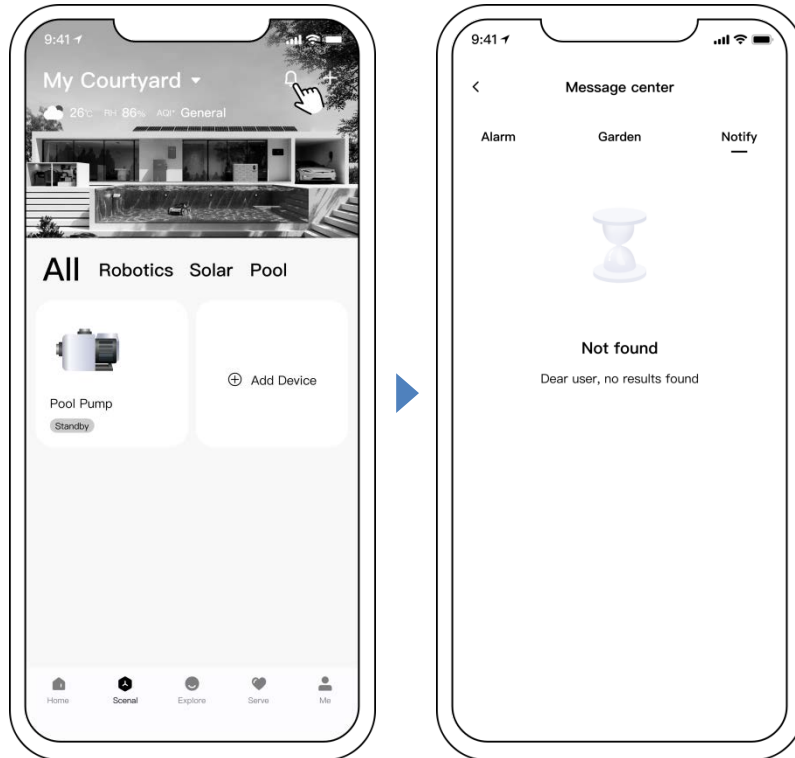

B: Push-Einstellungen: Klicken Sie auf der Einstellungsseite auf [Push-Einstellungen], um die Seite mit den Push-Einstellungen aufzurufen. Benutzer können die Push-Einstellungen entsprechend der Nachrichtenklassifizierung festlegen, wie unten dargestellt:

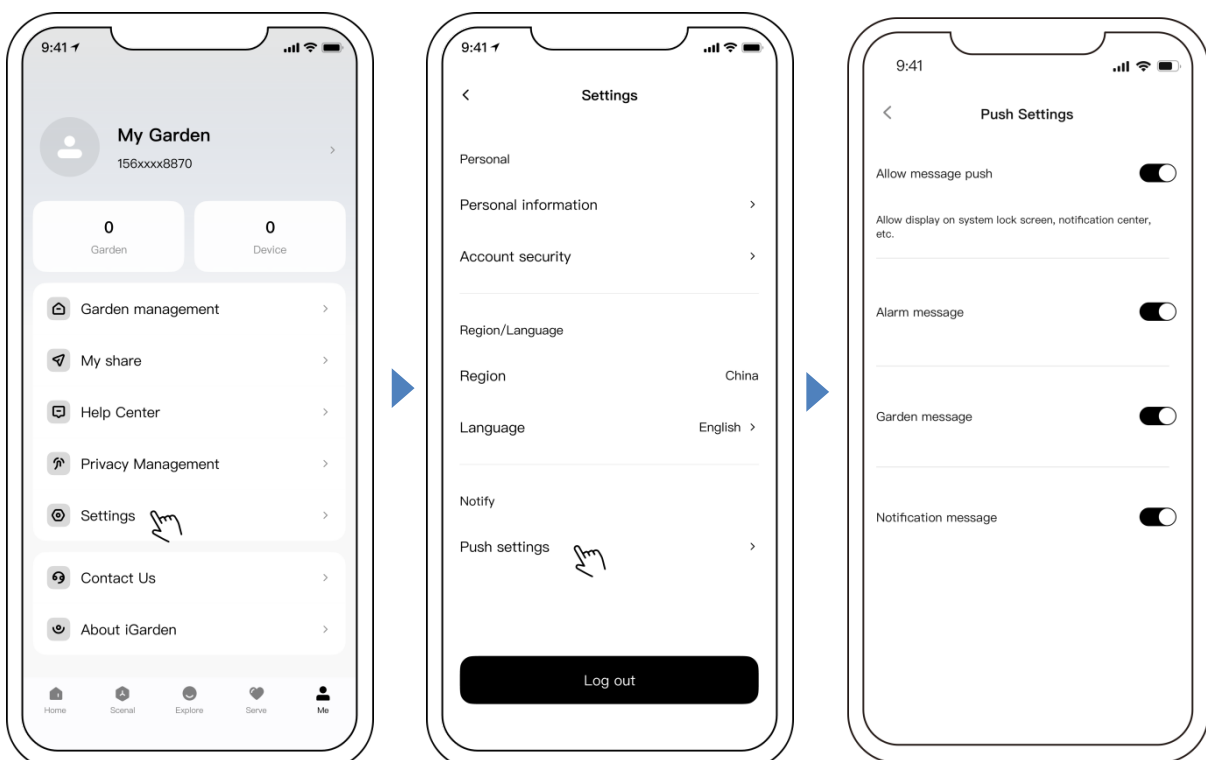

8 Rückmeldung

Sollten Sie bei der Nutzung auf Probleme stoßen, freuen wir uns über Ihr Feedback. Der Ablauf ist wie folgt:

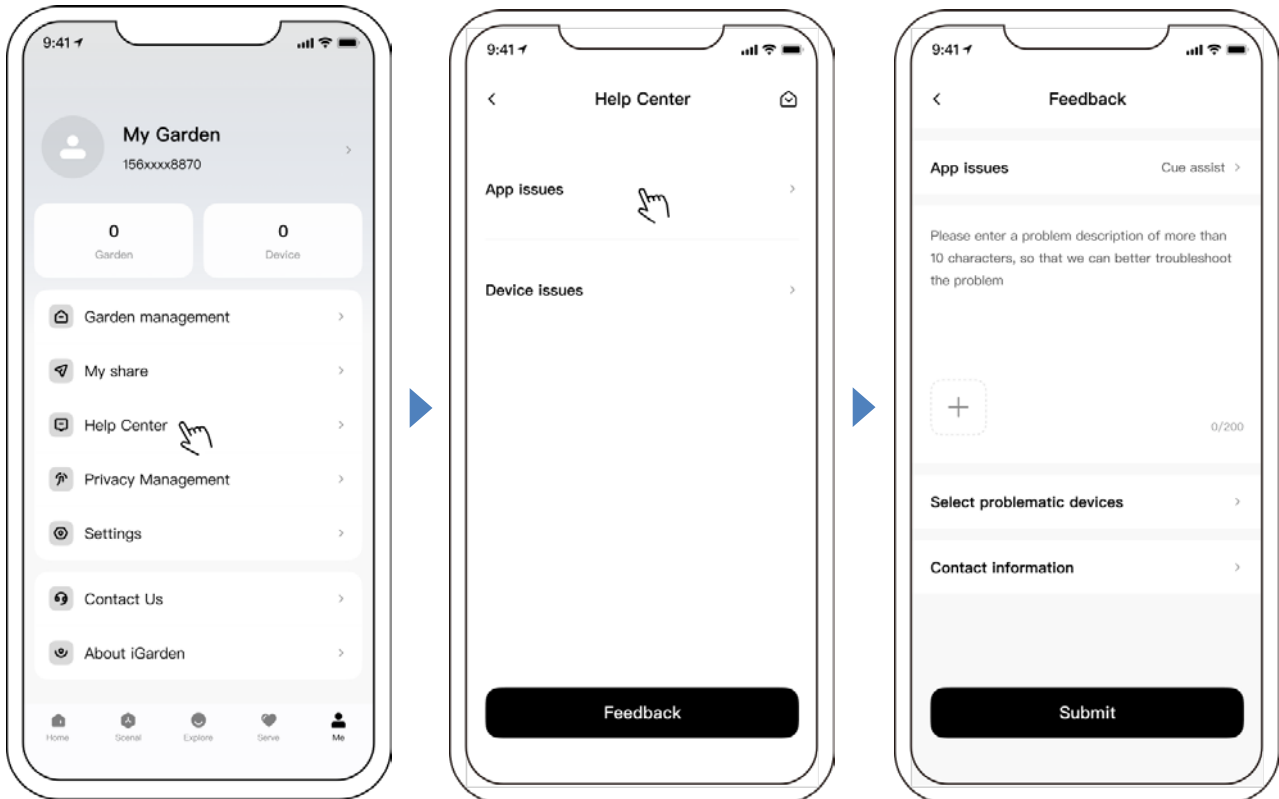

Beachten:

- 1) Die Wettervorhersage dient nur als Orientierungshilfe;
- 2) Die Angaben zum Stromverbrauch dienen nur als Referenz, da sie durch Netzwerkprobleme und Ungenauigkeiten der Berechnung beeinflusst werden können;
- 3) Die App kann ohne vorherige Ankündigung aktualisiert werden.

7 EXTERNE STEUERUNG

Die externe Steuerung kann über die folgenden Kontakte aktiviert werden. Sind mehrere externe Steuerungen aktiviert, gilt folgende Priorität: Digitaler Eingang > RS485 > Bedienfeldsteuerung



Abbildung 5 – Position des Anschlusses



Abbildung 6 – Anschluss für Digital-Eingang und RS485

Wechselstromeingang (geeignet für 115 V und 230 V)

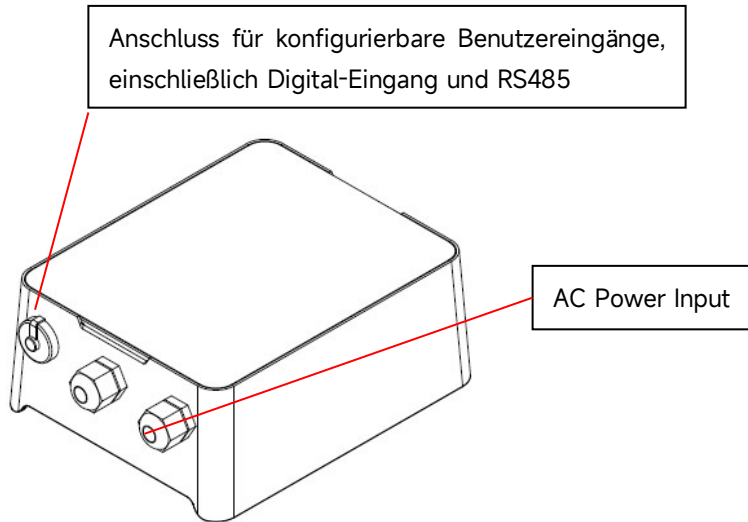

Abbildung 7 – Anschluss des Netzkabels

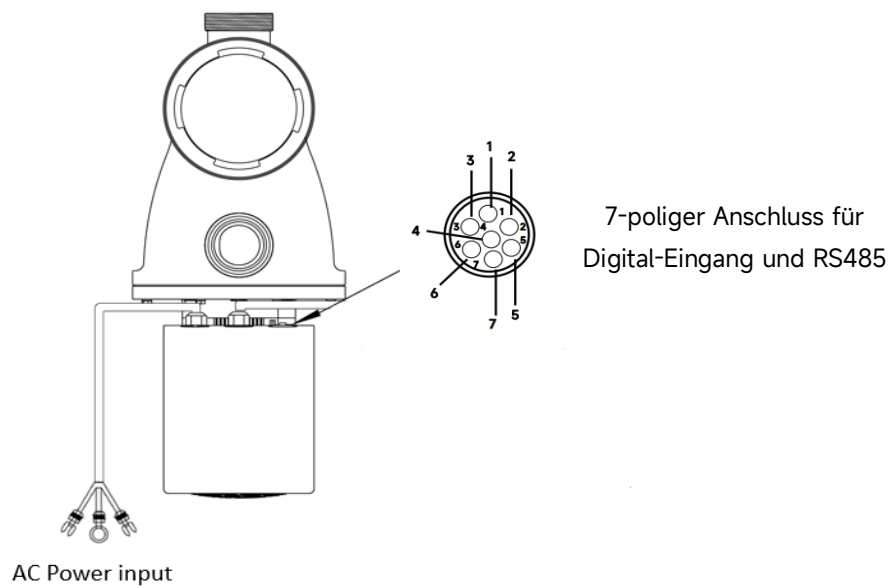
Externe Steuerung	Farbe	Beschreibung	Notiz
Digitaler Eingang	Rot	Di4 (Digitaler Eingang 4)	Standardgeschwindigkeit = 40 %
	Schwarz	Di3 (Digitaler Eingang 3)	Standardgeschwindigkeit = 80 %
	Weiß	Di2 (Digitaler Eingang 2)	Standardgeschwindigkeit = 100 %
	Grau	Di1 (Digitaler Eingang 1)	Stoppen
	Gelb	Digital Ground (COM)	COM
RS485	Grün	RS485-A	/
	Braun	RS485-B	/

a. Digitaler Eingang

Die Laufleistung wird durch den Zustand des digitalen Eingangs bestimmt.

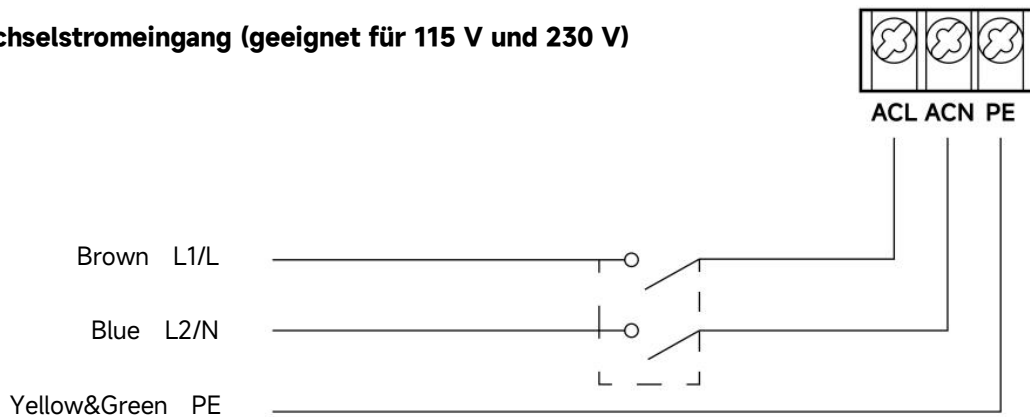
- 1) Wenn Di1 (Grau) mit COM (Gelb) verbunden ist, muss die Pumpe zwangsweise gestoppt werden; bei einer Unterbrechung ist die digitale Steuerung ungültig.
- 2) Wenn Di2 (Weiß) mit COM (Gelb) verbunden ist, läuft die Pumpe zwangsläufig mit 100 % Leistung; bei Trennung der Verbindung wird die Steuerungspriorität wieder auf die Bedienfeldsteuerung zurückgesetzt.
- 3) Wenn Di3 (Schwarz) mit COM (Gelb) verbunden ist, muss die Pumpe zwangsweise mit 80 % laufen; wenn die Verbindung getrennt ist, wird die Steuerungspriorität wieder auf die Bedienfeldsteuerung zurückgesetzt;
- 4) Wenn Di4 (Rot) mit COM (Gelb) verbunden ist, muss die Pumpe zwangsweise mit 40 % laufen; wenn die Verbindung getrennt ist, wird die Steuerungspriorität wieder auf die Bedienfeldsteuerung zurückgesetzt;
- 5) Die Kapazität der Eingänge (Di2/Di3/Di4) kann je nach Parametereinstellung verändert werden.

b. RS485

Um eine Verbindung mit RS485-A (Grün) und RS485-B (Braun) herzustellen, kann die Pumpe über das Modbus 485-Kommunikationsprotokoll gesteuert werden.

8 SCHUTZ UND AUSFALL

8.1 vor hoher Temperatur und Geschwindigkeitsreduzierung - AL01

In "Auto Wechselrichter/Handbuch Im Inverter-Modus und im Timer-Modus (außer R ü cksp ü l-/Selbstansaugmodus) wird bei Erreichen der Hochtemperatur - Warnschwelle (81 ° C) ein Hochtemperatur-Warnmodus aktiviert . Sinkt die Temperatur auf die Aufhebungsschwelle (78 °C), wird der Hochtemperatur-Warnmodus aufgehoben . Im Display werden abwechselnd AL01 und die Betriebsdrehzahl bzw. der Durchfluss angezeigt .

Wird AL01 angezeigt , wird die Betriebskapazität automatisch wie folgt reduziert:

- 1) Wenn die aktuelle Betriebskapazität über 100 % liegt, wird die Betriebskapazität automatisch auf 85 % reduziert .
- 2) Liegt die aktuelle Betriebskapazität zwischen 85 % und 100 %, wird die Betriebskapazität automatisch um 15 % reduziert.
- 3) Liegt die aktuelle Betriebskapazität zwischen 70 % und 85 %, wird die Betriebskapazität automatisch um 10 % reduziert.
- 4) Wenn die aktuelle Betriebskapazität unter 70 % liegt, wird die Betriebskapazität automatisch um 5 % reduziert.

8.2 Unterspannungsschutz - AL02

Das Gerät ist sowohl mit 230V- als auch mit 115V- Wechselstromanschluss kompatibel .

① Wechselstromeingang: 230 V

Wenn das Gerät erkennt, dass die Eingangsspannung unter 198 V liegt, begrenzt es die aktuelle Drehzahl. Im Display werden abwechselnd AL02 und Drehzahl bzw. Durchfluss angezeigt.

- 1) Bei einer Eingangsspannung von 180 V oder weniger ist die Betriebskapazität auf 70 % begrenzt.
- 2) Bei einer Eingangsspannung zwischen 180 V und 190 V ist die Betriebskapazität auf 75 % begrenzt.
- 3) Bei einem Eingangsspannungsbereich zwischen 190 V und 198 V ist die Betriebskapazität auf 85 % begrenzt .

② Wechselstromeingang: 115 V

Wenn das Gerät erkennt, dass die Eingangsspannung unter 98 V liegt, begrenzt es die aktuelle Drehzahl. Im Display werden abwechselnd AL02 und Drehzahl bzw. Durchfluss angezeigt.

- 5) Bei einer Eingangsspannung zwischen 85 V und 90 V ist die Betriebskapazität auf 75 % begrenzt.
- 6) Bei einer Eingangsspannung zwischen 90 V und 98 V ist die Betriebskapazität auf 85 % begrenzt .

Hinweis: Wenn die Eingangsspannung weniger als 85 V beträgt, wird der Fehlercode E001 (Abnormale Eingangsspannung, siehe 8.4) angezeigt.

8.3 Fehlerbehebung

Problem	Mögliche Ursachen und Lösung
Pumpe startet nicht	<ul style="list-style-type: none"> • Stromversorgungsfehler, unterbrochene oder defekte Verkabelung. • Sicherungen durchgebrannt oder thermische Überlastung ausgelöst. • Prüfen Sie, ob sich die Motorwelle frei drehen lässt und ob keine Blockierungen vorliegen. • Aufgrund längerer Stillstandszeit. Trennen Sie das Netzteil und drehen Sie die hintere Motorwelle einige Male von Hand mit einem Schraubendreher.
Die Pumpe saugt nicht an.	<ul style="list-style-type: none"> • Pumpen-/Siebgehäuse leeren. Stellen Sie sicher, dass das Pumpen-/Siebgehäuse mit Wasser gefüllt ist und der O-Ring des Deckels sauber ist. • Lose Verbindungen auf der Saugseite. • Mit Ablagerungen gefüllter Siebkorb oder Skimmerkorb. • Saugseite verstopft. • Ist der Abstand zwischen Pumpeneinlass und Flüssigkeitsspiegel größer als 2 m, sollte die Einbauhöhe der Pumpe verringert werden.
Niedrigwasserstand	<ul style="list-style-type: none"> • Die Pumpe saugt nicht an. • Luft strömt in die Saugleitung. • Korb voller Schutt. • Unzureichender Wasserstand im Pool.
Die Pumpe ist laut	<ul style="list-style-type: none"> • Luftleck in der Saugleitung, Kavitation aufgrund einer verengten oder unterdimensionierten Saugleitung oder eines Lecks an einer Verbindungsstelle, niedriger Wasserstand im Becken und ungehinderte Rücklaufleitungen. • Vibrationen, die durch unsachgemäße Installation usw. verursacht werden. • Beschädigtes Motorlager oder Laufrad (Reparatur muss beim Lieferanten vorgenommen werden).

8.4 Fehlercode

Wenn das Gerät einen Fehler erkennt, stoppt es automatisch und zeigt den Fehlercode an . Überprüfen Sie nach 15 Sekunden, ob der Fehler behoben ist . Wenn die Verstopfung behoben ist, nimmt die Pumpe ihren Betrieb wieder auf .

Artikel	Fehlercode	Details	
1	E01	Beschreibung	Anomale Eingangsspannung : Die Versorgungsspannung liegt außerhalb des Bereichs von 165 V bis 275 V.

		Verfahren	Die Pumpe stoppt automatisch für 15 Sekunden und nimmt die Arbeit wieder auf, wenn sie erkennt, dass die Versorgungsspannung im zulässigen Bereich liegt.
2	E02	Beschreibung	Ausgangsüberstrom: Der Spitzenstrom der Pumpe ist höher als der Schutzstrom.
		Verfahren	Die Pumpe schaltet sich automatisch für 15 Sekunden ab und dann Wenn dies dreimal hintereinander passiert , schaltet sich die Pumpe ab und muss überprüft werden . Manuell neu gestartet .
3	E102	Beschreibung	Kühlkörper Fehler: Die Kühlkörpertemperatur erreicht 91 °C für 10 Sekunden . Oder der Kühlkörpersensor erkennt einen offenen oder Kurzschluss .
		Verfahren	1. Die Pumpe stoppt automatisch für 30 Sekunden und nimmt die Arbeit wieder auf, wenn sie erkennt, dass die Temperatur des Kühlkörpers unter 81 °C liegt. 2. Die Pumpe schaltet sich automatisch für 15 Sekunden ab. und nimmt den Betrieb wieder auf, wenn erkannt wird, dass der Kühlkörpersensor nicht unterbrochen oder kurzgeschlossen ist .
4	E103	Beschreibung	auf der Master-Treiberplatine: Der Haupttreiberplatine ist fehlerhaft.
		Verfahren	Die Pumpe schaltet sich automatisch für 15 Sekunden ab und dann Wenn dies dreimal hintereinander passiert , schaltet sich die Pumpe ab und muss überprüft werden . Manuell neu gestartet .
5	E104	Beschreibung	Phasenausfallschutz: Die Motorkabel sind nicht an die Hauptantriebsplatine angeschlossen .
		Verfahren	Die Pumpe schaltet sich automatisch für 15 Sekunden ab und dann Wenn dies dreimal hintereinander passiert , schaltet sich die Pumpe ab und muss überprüft werden . Manuell neu gestartet .
6	E203	Beschreibung	beim Lesen der Echtzeituhrzeit : Lese- und Schreibfehler Die Zeitangabe der Uhr ist fehlerhaft .
		Verfahren	Der Die Pumpe muss muss ausgeschaltet und manuell neu gestartet werden.
7	E204	Beschreibung	Lesefehler im EEPROM der Anzeigeplatine : Lesen und Schreiben die Informationen von Das EEPROM der Anzeigeplatine ist falsch .
		Verfahren	Der Die Pumpe muss muss ausgeschaltet und manuell neu gestartet werden.
8	E205	Beschreibung	Kommunikationsfehler : Der Die Kommunikation zwischen Anzeigeplatine und Master -Treiberplatine ist für 15 Sekunden

			unterbrochen.
		Verfahren	Die Pumpe schaltet sich automatisch für 15 Sekunden ab. und setzt die Arbeit fort, wenn erkannt wird, dass die Kommunikation zwischen Anzeigeplatine und Master -Treiberplatine 1 Sekunde lang andauert.
9	E207	Beschreibung	Kein Wasserschutz : Die Pumpe hat keinen Wasseranschluss.
		Verfahren	abstellen , mit Wasser füllen und wieder einschalten. Wenn dies zweimal hintereinander passiert, schaltet sich die Pumpe ab und muss manuell überprüft werden.
10	E209	Beschreibung	Ansaugverlust : Die Pumpe kann aufgrund von Gründen wie Überschreitung des Ansaugbereichs oder zu komplizierter Rohrleitung nicht selbstansaugen.
		Verfahren	Prüfen Sie, ob die Pumpe oder die Rohrleitung undicht ist, füllen Sie dann die Pumpe mit Wasser und starten Sie sie neu.

9 WARTUNG

Leeren Sie den Siebkorb regelmäßig. Kontrollieren Sie den Korb durch den transparenten Deckel und leeren Sie ihn, sobald sich darin deutlich Abfall angesammelt hat. Beachten Sie dabei folgende Hinweise:

- 1) Die Stromversorgung wurde unterbrochen.
- 2) Den Deckel des Siebkorbs gegen den Uhrzeigersinn abschrauben und abnehmen.
- 3). Heben Sie den Siebkorb an.
- 4) Leeren Sie den Korb mit dem darin verfangenen Abfall und spülen Sie die Rückstände gegebenenfalls aus.

Hinweis: Den Kunststoffkorb nicht auf eine harte Oberfläche stoßen, da dies zu Beschädigungen führen kann.

- 5) Überprüfen Sie den Korb auf Beschädigungen und ersetzen Sie ihn gegebenenfalls.
- 6) Prüfen Sie den O-Ring des Deckels auf Dehnung, Risse, Sprünge oder sonstige Beschädigungen.
- 7) Den Deckel wieder aufsetzen, handfestes Festziehen genügt.

Hinweis: Durch regelmäßiges Überprüfen und Reinigen des Siebkorbs kann dessen Lebensdauer verlängert werden.

10 GARANTIE & AUSSCHLÜSSE

Sollte während der Garantiezeit ein Mangel auftreten, wird der Hersteller nach eigenem Ermessen den betreffenden Artikel oder das betreffende Teil auf eigene Kosten reparieren oder ersetzen. Kunden müssen das im Garantieantragsverfahren beschriebene Vorgehen befolgen, um die Garantieleistungen in Anspruch nehmen zu können .

Die Garantie erlischt bei unsachgemäßer Installation, unsachgemäßer Bedienung, zweckentfremdetem Gebrauch, Manipulation oder Verwendung von nicht originalen Ersatzteilen.

11 ENTSORGUNG



bei der Entsorgung des Produkts als Elektro- oder Elektronikschrott oder geben Sie sie bei der örtlichen Abfallentsorgung ab.

Die getrennte Sammlung und das Recycling von Altgeräten bei der Entsorgung tragen dazu



bei, dass diese umwelt- und gesundheitsschonend recycelt werden. Informationen zu den

Sammelstellen für Ihre Wasserpumpe zum Recycling erhalten Sie bei Ihrer Gemeinde.

INHOUD

1. ⚠ BELANGRIJKE VEILIGHEIDSINSTRUCTIES	156
2. TECHNISCHE SPECIFICATIES	157
3. TOTALE AFMETINGEN (mm)	157
4. INSTALLATIE	158
5. INSTELLING EN BEDIENING	160
6. WIFI-WERKING (OPTIONEEL ITEM)	170
7. EXTERNE CONTROLE	179
8. BESCHERMING EN FALEN	181
9. ONDERHOUD	184
10. GARANTIE & UITSLUITINGEN	184
11. VERWIJDERING	185

BEDANKT VOOR DE AANKOOP VAN ONZE INVERTER-ZWEMBADPOMPEN.

DEZE HANDLEIDING BEVAT BELANGRIJKE INFORMATIE DIE U KAN HELPEN BIJ HET GEBRUIK EN ONDERHOUD VAN DIT PRODUCT.

LEES DE HANDLEIDING ZORGVULDIG DOOR VOOR DE INSTALLATIE EN HET GEBRUIK EN BEWAAR DEZE VOOR TOEKOMSTIG GEBRUIK.

1. BELANGRIJKE VEILIGHEIDSINSTRUCTIES

Bij de installatie en het gebruik van deze elektrische apparatuur dienen altijd de volgende veiligheidsmaatregelen in acht te worden genomen:

- 1) LEES EN VOLG ALLE INSTRUCTIES
- 2) WAARSCHUWING – Om het risico op letsel te verminderen, mag u kinderen dit product niet laten gebruiken, tenzij ze te allen tijde onder nauwlettend toezicht staan.
- 3) WAARSCHUWING – Risico op elektrische schok. Sluit het apparaat alleen aan op een aftakcircuit dat wordt beveiligd door een aardlekschakelaar (RCD) met een nominale aardlekstroom van maximaal 30 mA. Neem contact op met een gekwalificeerde elektricien als u niet kunt controleren of het circuit wordt beveiligd door een aardlekschakelaar (RCD).
- 4) OM HET RISICO OP ELEKTRISCHE SCHOKKEN TE VOORKOMEN, moet u de aardingsdraad op de motor (groen/geel) aansluiten op het aardingssysteem.
- 5) WAARSCHUWING – Om het risico op een elektrische schok te verminderen, dient u het beschadigde snoer onmiddellijk te vervangen.
- 6) Niet installeren in een buitenste omhulsel of onder de rand van een hottub of spa.
- 7) Er moet een scheidingsschakelaar worden geïnstalleerd op de vaste elektrische installatie in overeenstemming met de installatievoorschriften.
- 8) Voor gebruik bij zwembaden, hot tubs en spa's.
- 9) LET OP: Om het risico op een elektrische schok te verminderen, dient u de unit minimaal 1,8 meter van de binnenwanden van het zwembad te installeren. Gebruik geen verlengsnoer.
- 10) LET OP: Om een blijvende bescherming tegen elektrische schokken te garanderen, mag u bij het uitvoeren van onderhoud uitsluitend identieke vervangingsonderdelen gebruiken .
- 11) Deze pomp is geschikt voor gebruik met permanent geïnstalleerde zwembaden (zowel in de grond als bovengronds) en kan ook worden gebruikt bij hottubs en spa's met een watertemperatuur lager dan 50° C . Vanwege de vaste installatiemethode wordt deze pomp niet aanbevolen voor gebruik bij bovengrondse zwembaden, die gemakkelijk gedemonteerd kunnen worden voor opslag.
- 12) De pomp is niet onderdompelbaar.
- 13) Open nooit de binnenkant van de behuizing van de aandrijfmotor.
- 14) BEWAAR DEZE INSTRUCTIES

WAARSCHUWING:

- Vul de pomp met water voordat u hem start. Laat de pomp niet drooglopen. Bij drooglopen raakt de mechanische afdichting beschadigd en begint de pomp te lekken.
- Voordat u onderhoud aan de pomp uitvoert, schakelt u de stroom naar de pomp UIT door het hoofdcircuit naar de pomp los te koppelen en alle druk uit de pomp en het leidingsysteem te verwijderen.
- Draai de schroeven nooit vast of los terwijl de pomp draait.
- Zorg ervoor dat de inlaat en uitlaat van de pomp vrij zijn van vreemde voorwerpen.

2. HNISCHE SPECIFICATIES

Model	Geadviseerd zwembadvolume (m ³)	P1 KW	Spanning (V/Hz)	Qmax (m ³ /u)	Hmax (m)	Circulatie (m ³ /u)	
						Op 10m	Op 8m
DCP12-IG	40-70	1.2	220-240/ 50/60	28.0	21.0	23.0	26.0

3. ALE AFMETINGEN (mm)

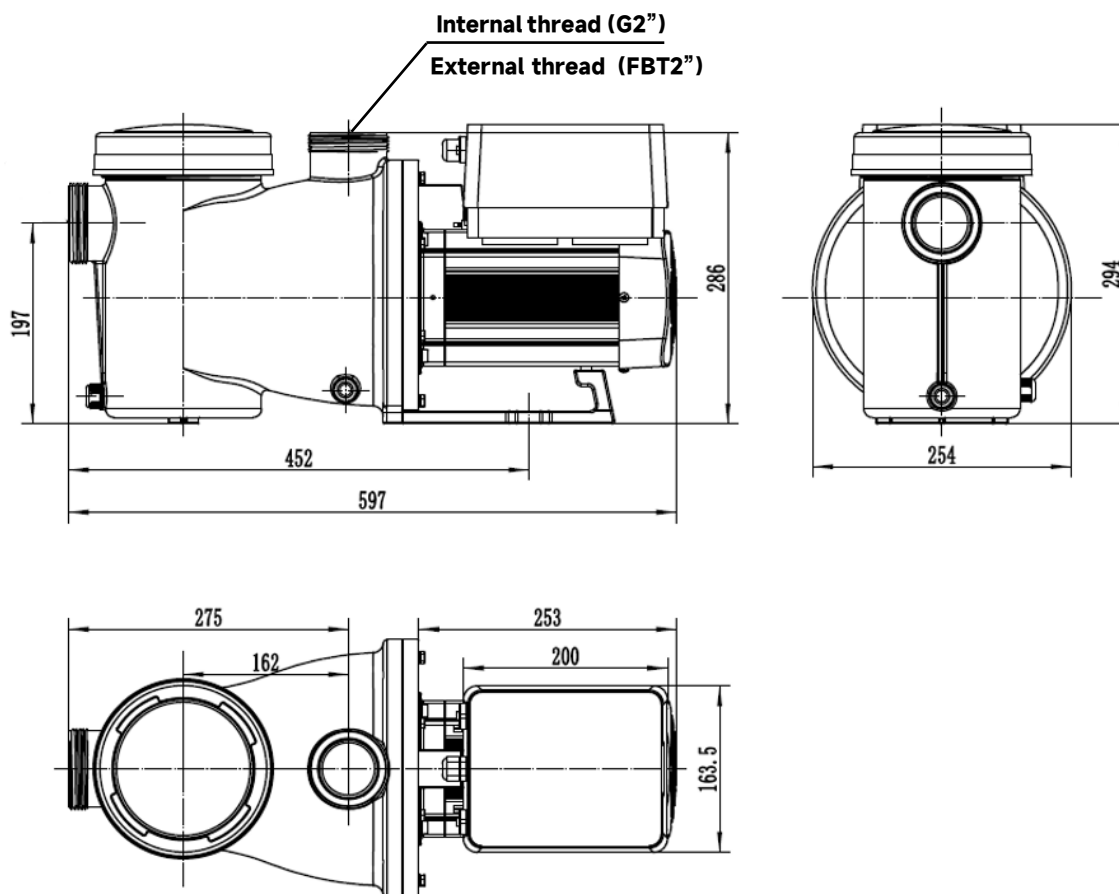

Afbeelding 1 - Afmetingen van de pomp

4. INSTALLATIE

4.1 Locatie van de pomp

- 1) Installeer de pomp zo dicht mogelijk bij het zwembad. Om wrijvingsverlies te beperken en de efficiëntie te verbeteren, gebruikt u korte, directe aanzuig- en retourleidingen.
- 2) Om direct zonlicht, hitte of regen te vermijden, raden wij u aan de pomp binnenshuis of in de schaduw te plaatsen.
- 3) Installeer de pomp NIET in een vochtige of ongeventileerde ruimte. Houd pomp en motor minimaal 150 mm uit de buurt van obstakels; pompmotoren hebben vrije luchtcirculatie nodig voor koeling.
- 4) De pomp moet horizontaal worden geïnstalleerd en met schroeven in het gat op de steun worden vastgezet om onnodig lawaai en trillingen te voorkomen.

4.2 Loodgieterswerk en kleppen

- 1) De inlaat-/uitlaataansluiting van de pomp: optioneel met metrisch (50 of 63 mm) of imperiaal (1,5 " of 2").
- 2) Voor optimale waterafvoer in het zwembad is het raadzaam een grotere leidingmaat te gebruiken. Het wordt aanbevolen om een leidingmaat 63mm te gebruiken..
- 3) Bij het monteren van de in- en uitlaatfittingen (verbindingen) met de leidingen dient u een speciale kit voor PVC-materiaal te gebruiken.
- 4) De diameter van de aanzuigleiding moet gelijk zijn aan of groter zijn dan de diameter van de inlaatleiding. Zo voorkomt u dat de pomp lucht aanzuigt, wat de efficiëntie van de pomp beïnvloedt.
- 5) Om wrijvingsverlies te beperken en de efficiëntie te verbeteren, moeten de leidingen aan de aanzuig- en retourzijde kort en direct zijn.
- 6) Bij overstroomde zuigsystemen moeten kleppen in zowel de aanzuig- als de retourleiding van de pomp worden geïnstalleerd, wat handig is voor routinematig onderhoud. Een klep, elleboog of T-stuk op de aanzuigleiding mag niet dicht bij de voorkant van de pomp worden geplaatst dan zeven keer de diameter van de aanzuigleiding.
- 7) Gebruik een terugslagklep in de retourleiding als er een aanzienlijke hoogte is tussen de retourleiding en de uitlaat van de pomp, om te voorkomen dat de pomp wordt blootgesteld aan de gevolgen van de recirculatie van het medium en dat de pomp door waterslag wordt gestopt .

4.3 Uitrusting

- 1) Bochten mogen niet dichterbij dan 350 mm bij de inlaat zitten. Installeer geen 90°-bochten direct in de inlaat/uitlaat van de pomp. Verbindingen moeten goed vastzitten.
- 2) Verbindingen moeten strak zitten.

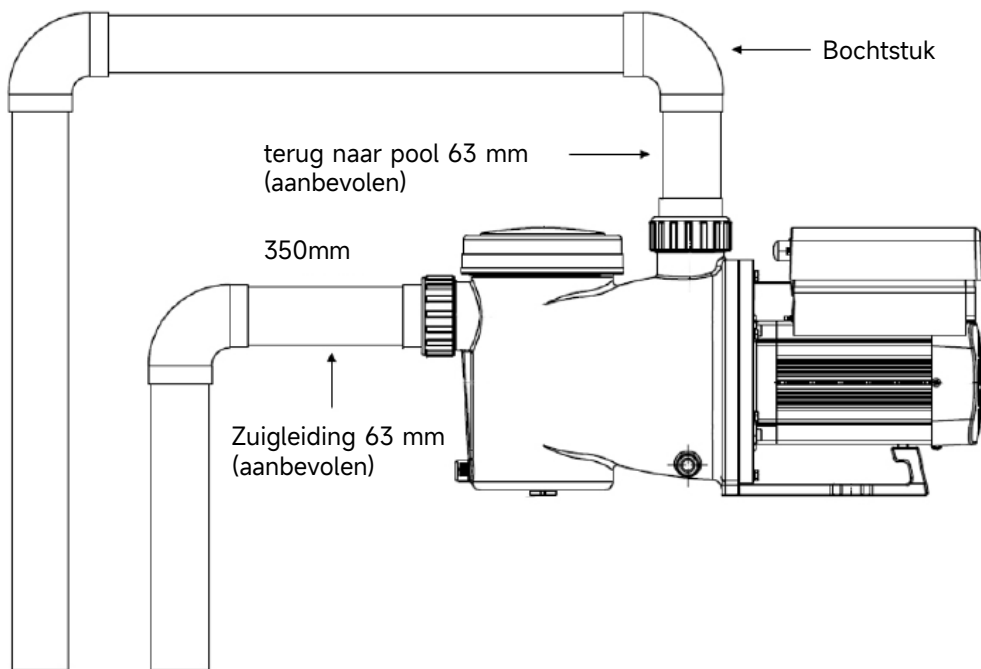

Figuur 2 - Installaties van leidingen en fittingen

* De inlaat-/uitlaatmaat van de pomp: optioneel met metrisch (50 of 63 mm) of imperiaal (1,5 " of 2")

- 3). Gebruik de UNION KIT die door de pompfabrikant wordt meegeleverd (zie afbeelding 3). Gebruik geen andere fittingen om de in- en uitlaat van de pomp aan te sluiten, omdat de fittingen anders niet op elkaar passen en de pompbehuizing beschadigd kan raken.

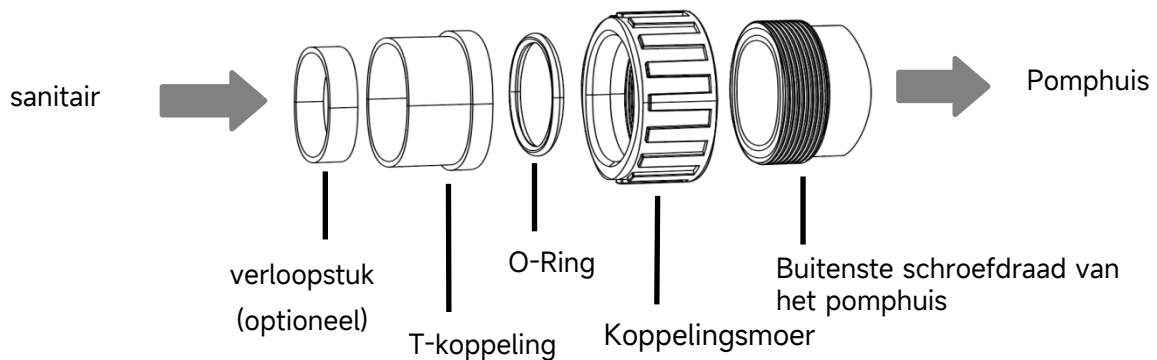

Figuur 3 - Koppelingsset

4.4 Controleer voor de eerste keer opstarten







- 1) Controleer of de pompas vrij kan draaien;
- 2) Controleer of de voedingsspanning en -frequentie overeenkomen met het typeplaatje;
- 3) Als u naar het ventilatorblad kijkt, moet de draairichting van de motor met de klok mee zijn;
- 4) Het is verboden de pomp te laten draaien zonder water.

4.5 Toepassingsvoorwaarden

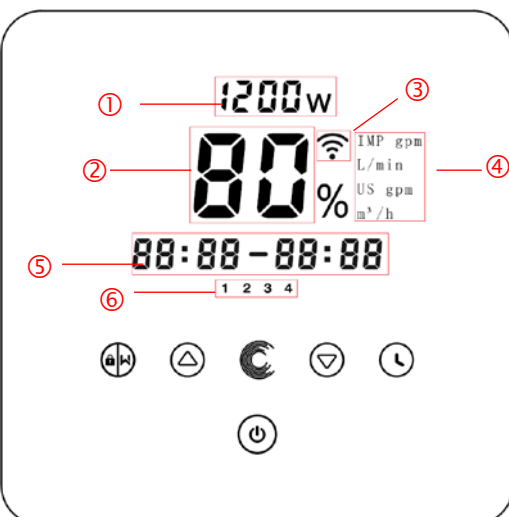
Omgevingstemperatuur	Binneninstallatie, temperatuurbereik: -10-42°C
Maximale watertemperatuur	50°C
Zout water beschikbaar	Zoutconcentratie tot 3,5%, d.w.z. 35 g/l
Vochtigheid	≤90% RV, (20°C±2°C)
Installatie	De pomp kan maximaal 2 m boven het waterniveau worden geïnstalleerd
Bescherming	Klasse F, IP55

5 INSTELLING EN BEDIENING



5.1 Weergave op bedieningspaneel

	① Stroomverbruik
	② Lopende capaciteit / Stroomsnelheid
	③ WIFI-indicator (optioneel item)
	④ Eenheid van stroming
	⑤ Timerperiode
	⑥ Timer 1/2/3/4
	 Terugspoelen/ontgrendelen
	 Omhoog/omlaag: om de waarde van de instelling te wijzigen
	 Schakelen tussen Handmatig Omvormermodus en Auto Omvormermodus. Handmatig Omvormermodus : De draaicapaciteit wordt handmatig ingesteld tussen 30% en 120 %. Auto Invertermodus : De bedrijfscapaciteit wordt automatisch aangepast tussen 30% en 120 %, afhankelijk van het vooraf ingestelde debiet. De standaardmodus is Handmatig Omvormer modus.
	 Timerinstelling
 Aan/uit	

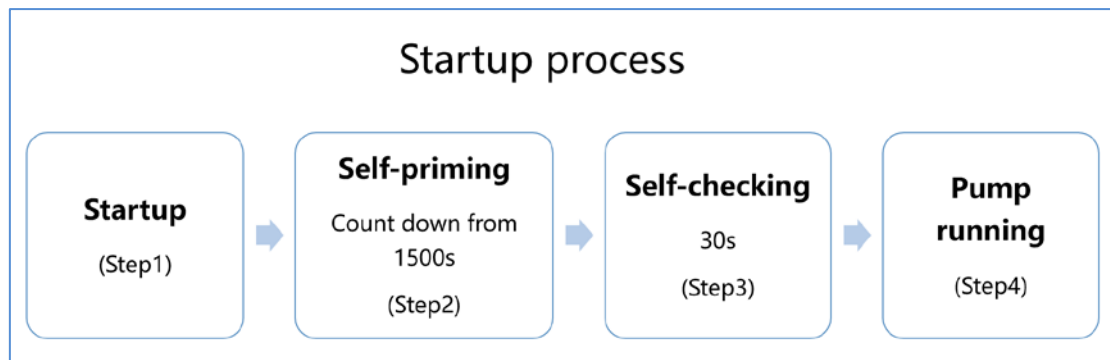
5.2 Opstarten proces o overzicht



① **Stap 1 : Opstarten**

- Houd de knop  langer dan 3 seconden ingedrukt om het scherm te ontgrendelen .
- Pers  naar opstarten de pomp.

② **Stap 2 : Zelfpriming**

- De pomp zal beginnen aftellen vanaf 1500 ; Wanneer het systeem detecteert dat de pomp vol water is, stopt het met aftellen en verlaat het automatisch de priming-modus.
- Gebruikers kunnen de parameterinstelling invoeren om de standaard zelf-aanzuigende functie uit te schakelen (zie 5.11) .



③ **Stap 3 : Zelfcontrole**

- De pomp Controleer nogmaals gedurende 30 seconden of het zelf-aanzuigen (stap 2) is voltooid .

④ **Stap 4 : Pomp rennen**

- Na zelf-aanzuiging draait de pomp bij de eerste opstart op 80% van de capaciteit.

5.3 Opstarten

Wanneer de stroom wordt ingeschakeld, zal het scherm 3 seconden volledig oplichten, de apparaatcode wordt weergegeven en het apparaat gaat vervolgens naar de normale werkstand. Wanneer het scherm vergrendeld is, werkt alleen de knop  licht op; Houd de toets  langer dan 3 seconden ingedrukt om het scherm te ontgrendelen. Het scherm wordt automatisch vergrendeld wanneer er langer dan 1 minuut geen bediening plaatsvindt en de helderheid van het scherm wordt verlaagd tot 1/3 van de normale weergave. Druk kort  om het scherm te activeren en de relevante bedrijfsparameters te bekijken.

5.4 Zelf-aanzuigend

Elke keer dat de pomp wordt gestart, begint deze zichzelf aan te zuigen.

Wanneer de pomp werkt zelf-aanzuigend, het zal aftellen vanaf 1500 seconden en stopt het aftellen automatisch wanneer het systeem detecteert dat de pomp vol water zit. Vervolgens controleert het systeem opnieuw gedurende 30 seconden om er zeker van te zijn dat het zelf-aanzuigen is voltooid.



Gebruikers kunnen het zelf-aanzuigen handmatig  annuleren door op te drukken langer dan 3 seconden. De pomp schakelt bij de eerste keer opstarten over naar de standaard handmatige invertermodus.

Opmerking:

dat de pomp opnieuw opstart, voert deze automatisch zelfaanzuiging uit. Gebruikers kunnen de parameterinstelling gebruiken om de standaard zelfaanzuigende functie uit te schakelen (zie 5.11).

5.5 Terugspoeling











Gebruikers kunnen het terugspoelen of de snelle recirculatie in elke bedrijfstoestand starten door op te drukken .

	Standaard	Instelbereik
Tijd	jaren 180	Druk op  of  om aan te passen van 0 tot 1500 seconden met 30 seconden voor elke stap
Lopende capaciteit	100%	60-100%, voer de parameterinstelling in (zie 5.11)

Uitgangs -terugspoeling:

Wanneer de backwash-modus is ingeschakeld, kunnen gebruikers deze 3 seconden ingedrukt houden  om te annuleren. De pomp keert dan terug naar de vorige stand van vóór de backwash. Als de gebruiker een snelheidslimiet instelt, zal de capaciteit van de backwash de ingestelde snelheidslimiet niet overschrijden (zie 5.10).

5.6 Handmatig Omvormermodus









1		Houd  langer dan 3 seconden ingedrukt om het scherm te ontgrendelen .
2		Druk  om te starten. De pomp draait bij de eerste keer opstarten op 80% van de capaciteit na zelfaanzuiging.
3	 	Druk op  of  om de werkcapaciteit in te stellen tussen 30% en 120%, elke stap met 5% .
4		Druk  nogmaals om over te schakelen naar de Auto Inverter-modus.

Opmerking :

- 1) Wanneer de leidingdruk hoog is, kan de gebruiker de capaciteit instellen op 105%-120% om een adequate stroomsnelheid te behouden. De pomp draait dan op een hogere snelheid om de hoge leidingdruk te compenseren.
- 2) Bij een capaciteit van 105% tot 120% past de pomp automatisch de snelheid aan wanneer het maximale vermogen is bereikt.
- 3) gebruiker bijvoorbeeld de snelheid aanpast op 110 %, als de pomp Het vermogen heeft bij deze snelheid de maximale waarde bereikt . Op dat moment zal de pomp, zelfs als de gebruiker de pompsnelheid blijft verhogen tot 120% , de snelheid op maximaal vermogen, d.w.z. 110 % , handhaven . De weergegeven snelheid zal dalen van 120% naar 110%.

5.7 Auto Omvormermodus

In de automatische invertermodus kan de pomp automatisch de systeemdruk detecteren en de snelheid van de motor aanpassen om de ingestelde stroomsnelheid te bereiken.

1		Ontgrendel het scherm en druk op deze knop  om over te schakelen van de handmatige invertermodus naar de automatische invertermodus.
2	 	De stroomsnelheid kon worden aangepast door op de knop te drukken  of  met 1 m ³ /h voor elke stap.
3	 	De eenheid van de stroomsnelheid kan worden gewijzigd in L /min , IMP gpm of US gpm door op beide knoppen te drukken.   gedurende 3 seconden .
4		Druk  om over te schakelen naar de handmatige invertermodus .

Het standaard instelbare stroombereik voor InverK is als volgt :

Model	Een instelbaar debietbereik*
DCP12-IG	8-25 m ³ /h

*** Opmerking :**











In de Auto Inverter-modus is de maximaal instelbare stroomsnelheid gebaseerd op een opvoerhoogte van ongeveer 8 meter.

Als gebruikers de stroomsnelheid instellen op de maximale instelbare stroomsnelheid en de leidingdruk hoger is dan 8 m, zal de pomp in deze situatie automatisch de draaisnelheid en het ingangsvermogen verhogen om de hoge druk tegen te gaan en de maximale stroomsnelheid die de gebruiker heeft ingesteld, te handhaven.

Wanneer het motortoerental en het ingangsvermogen tot het maximumniveau stijgen, maar dit niet voldoende is om de enorme druk in de leiding te compenseren, zal de op de pompcontroller weergegeven flow dalen van de ingestelde flow naar de werkelijk haalbare flow .

5.8 Timermodus

De aan/uit- en draaicapaciteit van de pomp kan worden aangestuurd door een timer, die indien nodig dagelijks geprogrammeerd kon worden.



1	Ga naar de timerinstelling door op te drukken 
2	Druk op  of  om de lokale tijd in te stellen
3	Druk  om te bevestigen en naar de tijd-1-instelling te gaan
4	Pers  of  om de gewenste looptijden , looptijdcapaciteit of stroomsnelheid te kiezen (wanneer het %-icoon knippert, kunnen gebruikers de stroomsnelheid wijzigen door op te drukken 
5	 Herhaal de bovenstaande stappen om de andere 3 timers
6	 Houd 3 seconden ingedrukt om de instelling op te slaan en de timermodus te activeren
7	 of  Controleer 4 timers om er zeker van te zijn dat er geen ongeldige instellingen zijn



Opmerking:

1. Als de ingestelde tijdsperiode de huidige tijd bevat, zal de pomp gaan draaien volgens de ingestelde bedrijfscapaciteit of het ingestelde debiet, de huidige timerindicator  (1 of 2 of 3 of 4) zal oplichten en het gebied **88:88 - 88:88** zal de overeenkomstige tijdsperiode weergeven.
2. Als de ingestelde tijdsperiode niet de huidige tijd bevat, wordt het timernummer  (1 of 2 of 3 of 4) dat op het punt staat te gaan rennen, wordt weergegeven en knippert, en het gebied **88:88 - 88:88** zal de overeenkomstige tijdsperiode weergeven.
3. Als u tijdens het instellen van de timer terug wilt naar de vorige instelling, houdt u beide knoppen ingedrukt   3 seconden ingedrukt houden. Als u niet alle 4 de timers hoeft in te stellen, kunt u  3 seconden ingedrukt houden. Het systeem slaat dan automatisch de huidige ingestelde waarde op en activeert de timermodus.
4. De timerinstellingen van de pomp zijn beperkt; gebruikers kunnen geen overlappende timers instellen.
5. Nadat de timer is ingesteld en de gebruiker de pomp heeft uitgeschakeld, zal deze terugkeren naar de timermodus wanneer de gebruiker de pomp weer inschakelt.
6. Gebruikers kunnen de timermodus annuleren door op te drukken .

5.9 Schuimspaan Mode

De skimmermodus zorgt ervoor dat de pomp het wateroppervlak afschuimt, waardoor vuil zich niet kan ophopen en gebruikers een schoner zwembad krijgen.

Houd en  ingedrukt om de preset-interface van de skimmermodus te openen. Wanneer u voor het eerst naar deze modus overschakelt, wordt preset 1 geactiveerd .

Gebruikers kunnen op  of drukken  om de 4 voorinstellingen te bekijken. Hieronder vindt u de details van elke voorinstelling. De geselecteerde voorinstelling wordt na 5 seconden zonder bediening geactiveerd.

Preset	skimmer- cyclus	Skimmer duur	Skimmer snelheid	Tijdsperiode	Opmerking
1	1 uur	3 minuten	100%	7:00 – 21:00 uur	Bewerkbaar in parameterinstelling
2	1 uur	10 min	100%	7:00 – 21:00 uur	Niet bewerkbaar
3	3 uur	3 minuten	80%	7:00 – 21:00 uur	Niet bewerkbaar
4	Schakel de skimmermodus uit				Niet bewerkbaar

Tabel 1 - Voorinstellingen van de skimmermodus

Tijdens de skimmerduur zal de controller de parameter van de voorinstelling weergeven , de gebruiker kan deze vasthouden  3 seconden ingedrukt om de skimmertijd telkens te annuleren . Wanneer de skimmertijd is verstreken, keert de pomp terug naar de normale stand, zodat de gebruiker weer kan werken.

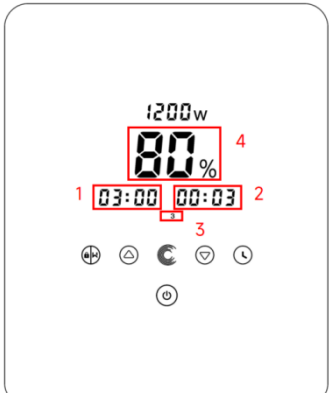
	<ol style="list-style-type: none"> 1. Skimmercyclus (uur) 2. Skimmerduur (minuten) 3. Skimmer-modus vooraf ingesteld nummer 4. Skimmersnelheid/ stroomsnelheid
--	--

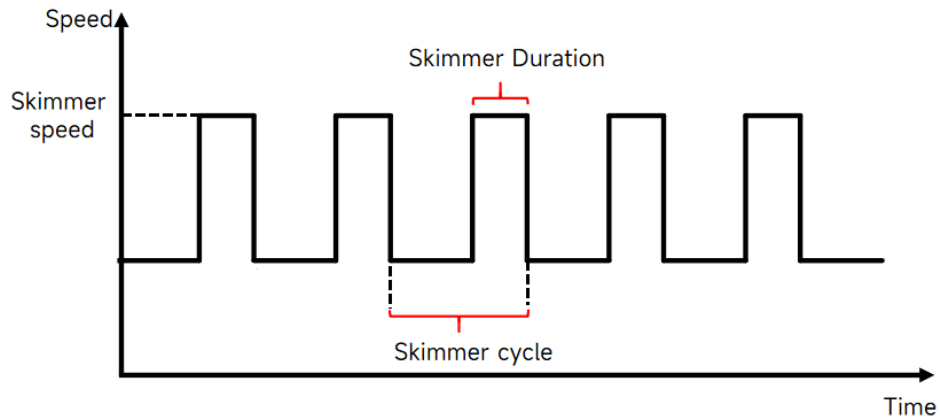

Figuur 4 - Skimmercyclus

5.10 Snelheids- / stroomlimiet

Gebruikers kunnen de snelheids- /stroomlimiet van de pomp instellen om te voldoen aan de stroomvereisten van andere apparatuur, zoals zandfilters.









De snelheids- / stroomlimiet van de pomp kan worden ingesteld in de parameterinstelling. (zie 5.1.1)



100% betekent dat er geen snelheidslimiet is en dat de capaciteit bij normaal gebruik kan worden ingesteld van 30% - 120%.



Model	Snelheids-/stroomlimiet	
	Maximale loopsnelheid	Maximale stroomsnelheid
DCP12-IG	60%-100%	15-25 m ³ /h

Om de prestaties te garanderen, wordt bij elke start het zelf -primingproces uitgevoerd . wordt niet beperkt door de snelheids- / stroomlimietfunctie .





5.11 Parameterinstelling

Fabrieksinstellingen herstellen	Schakel de pomp uit en houd vervolgens beide   gedurende 3 seconden
Controleer de softwareversie	Schakel de pomp uit en houd vervolgens beide   gedurende 3 seconden
Voer de parameterinstelling in zoals hieronder	Schakel de pomp uit en houd vervolgens beide   gedurende 3 seconden; Pers  om het parameteradres te selecteren en druk op  of  om de parameterinstelling aan te passen.

Parameter Adres	Beschrijving	Standaardinstelling	Instelbereik
1	Di2 (Digitale ingang 2)	Snelheid: 100%	Snelheid: 30-120%, in stappen van 5% ; Stroom: 1 m ³ /h verhogingen; DCP12-IG: 8-25 m ³ /h Opmerking : druk op  naar overschakelen naar stroming tarief instelling .
2	Di3 (Digitale ingang 3)	Snelheid: 80%	
3	Di4 (Digitale ingang 4)	Snelheid: 40%	
4	Terugspoeling	Snelheid: 100%	Snelheid: 60-100% , in stappen van 5%; Stroom: met 1 m ³ /h verhogingen; DCP12-IG: 8-25 m ³ /h Opmerking : druk op  naar overschakelen naar stroming tarief instelling.
5	Besturingsmodus van analoge ingang	0	0 : Stroomregeling 1: Spanningsregeling
6	Schakel de zelf-aanzuiging bij elke start in of uit	25	25: maakt het mogelijk 0: schakelt uit
7	Gereserveerd	0	Niet bewerkbaar
8	Systeemtijd	00:00	00:00 - 23:59

9	Preset 1 van de skimmermodus	Skimmercyclus : 01:00 Skimmer duur : 00:03 Skimmersnelheid : 100 %	*Skimmercyclus: 1 - 24 uur, 1 uur voor elke stap ; *Skimmer duur: 1 - 30min, 1min voor elke stap ; *Skimmersnelheid: 30%-100%, in stappen van 5%; *Skimmer flow: met 1 m ³ /h verhogingen; DCP12-IG: 8-25 m ³ /h Opmerking : druk op  naar overschakelen naar stroming tarief instelling.
10	Tijdperiode van de voorinstelling 1 van de skimmermodus	7:00 - 21:00 uur	Starttijd: 00:00 - 24:00 Eindtijd: 00:00-24:00
11	Snelheidslimiet	Snelheid: 100%	Snelheid : 60%-100%, in stappen van 5%; (100% betekent geen snelheidslimiet) Stroom : met 1 m ³ /h verhogingen; DCP12-IG: 15-25 m ³ /h Opmerking : druk op  naar overschakelen naar stroming tarief instelling .
12	RS485-adres	170(0xAA)	160-190 (0xA0-0xBF), elke stap met 1.
13	Gereserveerd	0	Niet bewerkbaar

Bijvoorbeeld : Hoe in te schakelen / Zelf-aanzuigfunctie uitschakelen?

- c. Voer parameterinstelling in: Schakel de pomp uit en houd beide   gedurende 3 seconden;
- d. Selecteer parameteradres: Druk om  adres 6 te selecteren ;
- e. zelf- aanzuigfunctie in- of uitschakelen : Aanpassen door op  of te drukken , 2= Inschakelen, 0=Uitschakelen .

6. WIFI-WERKING (OPTIONEEL ITEM)

① Download iGarden APP



Android



iOS



② Accountregistratie

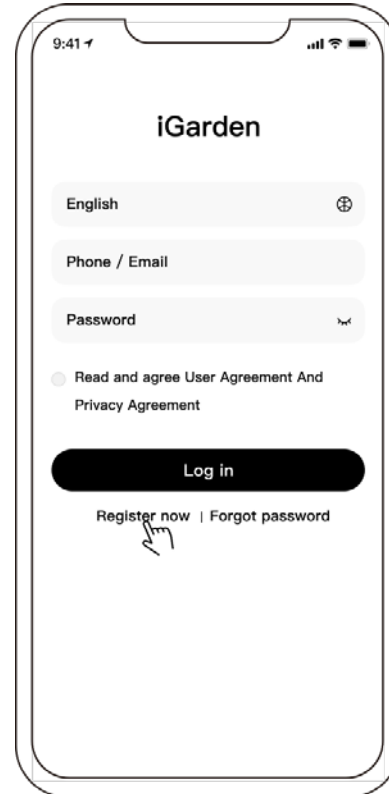

Registratie per telefoon/e-mail

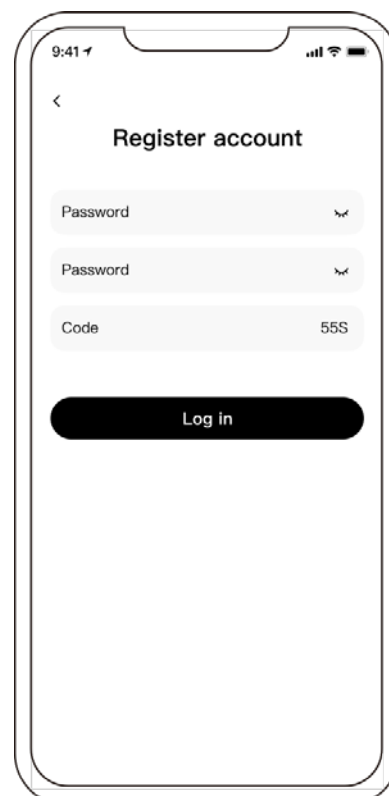
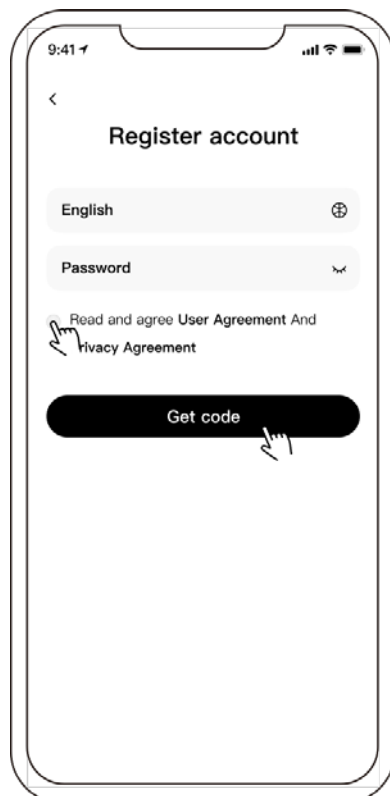



3 App -koppeling

Zorg ervoor dat uw pomp is ingeschakeld voordat u begint.

(Netwerkkoniditie: 2,4 GHz; 2,4 GHz en 5 GHz worden gecombineerd tot één SSID; maar geen afzonderlijk 5 GHz-netwerk)

1) Controleer of uw telefoon verbonden is met wifi en of Bluetooth op uw telefoon is ingeschakeld.

2) Druk  3 seconden in om het scherm te ontgrendelen. Na het inschakelen van de pomp, druk  5 seconden in totdat u een piepton hoort en laat dan los.  knippert.

3) Klik op 'Apparaat toevoegen' en volg de instructies om het apparaat te koppelen.

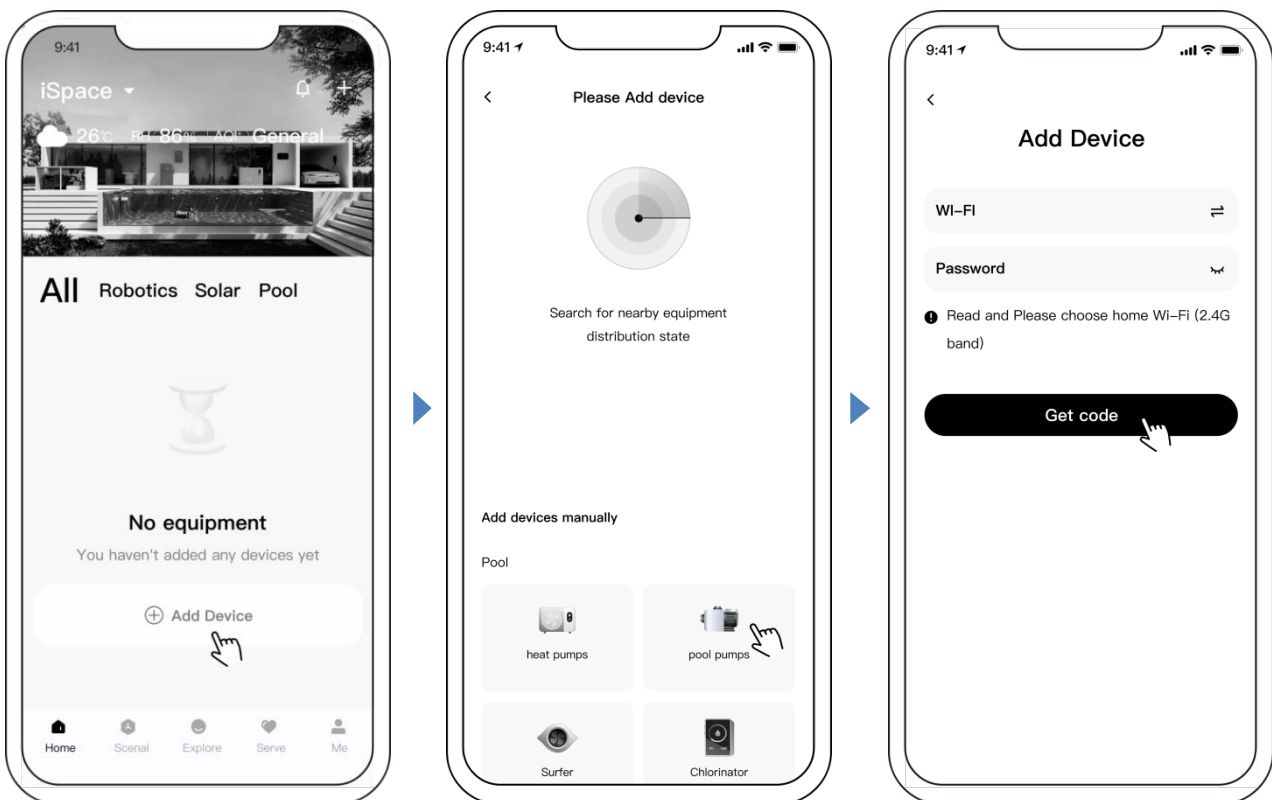

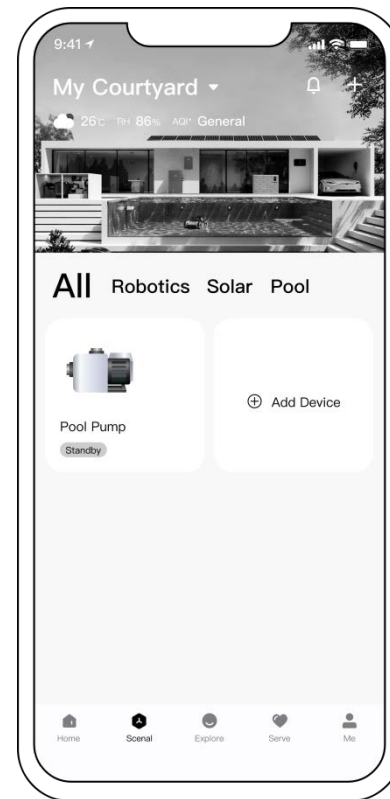
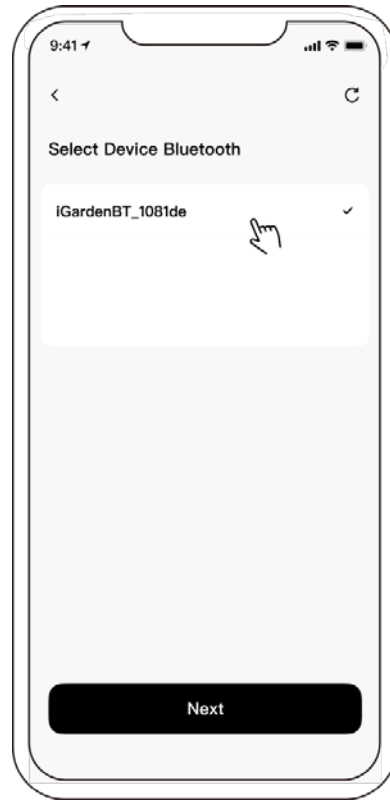
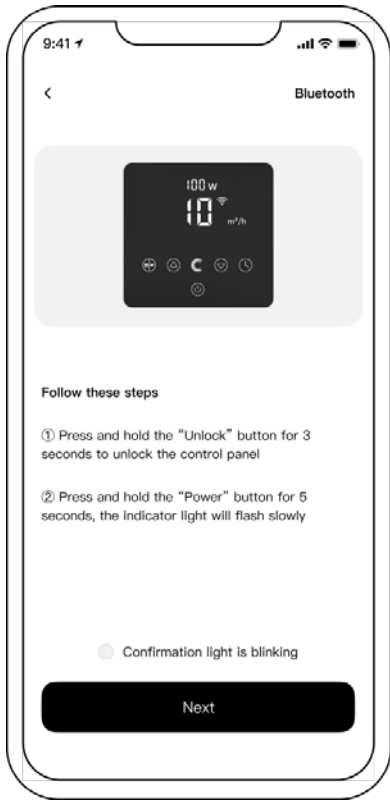

4 Operatie

1) Automatische omvormermodus (AI-modus):

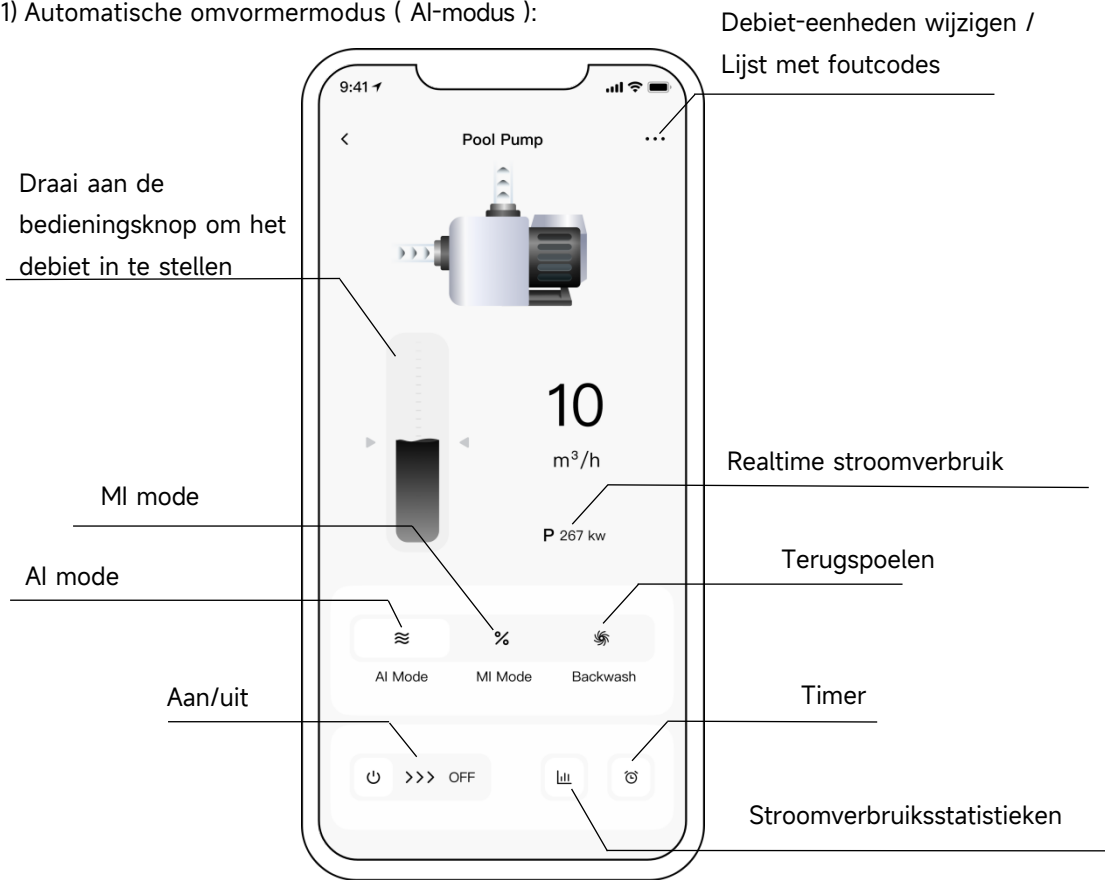

2) Handmatige invertermodus (MI-modus):

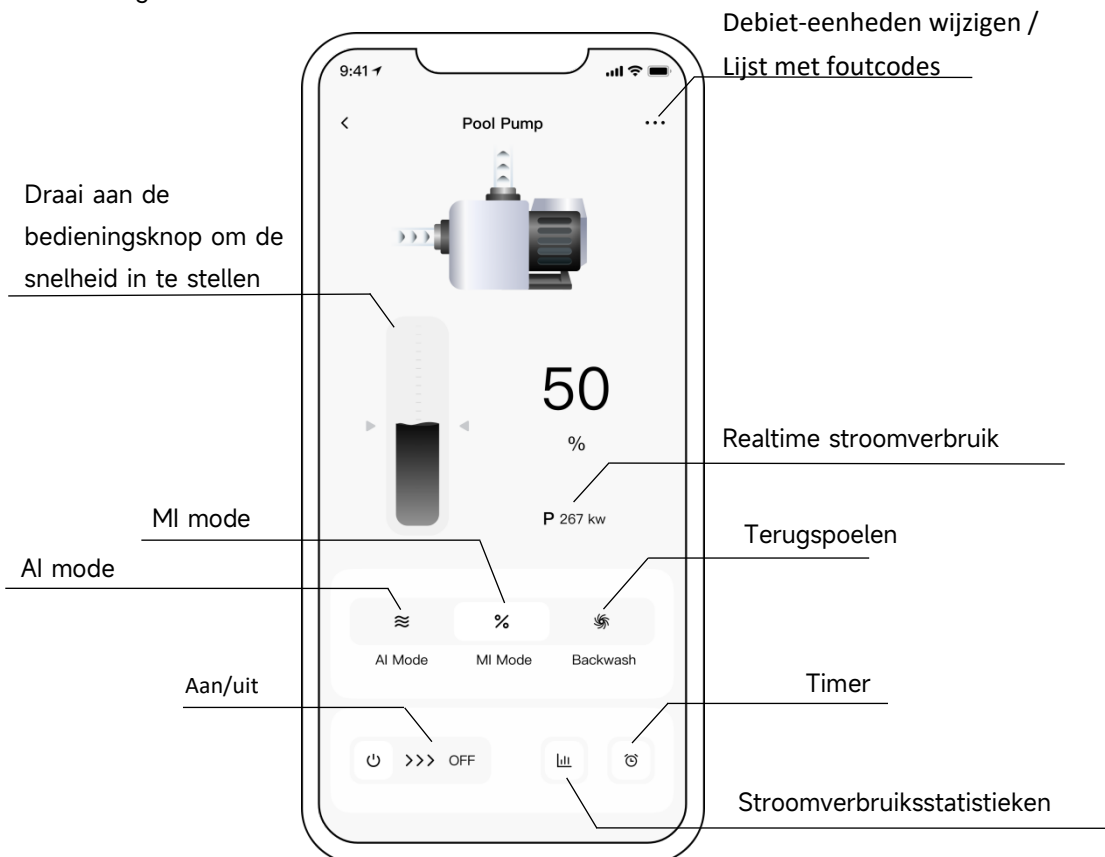

3) Terugspoelmodus:

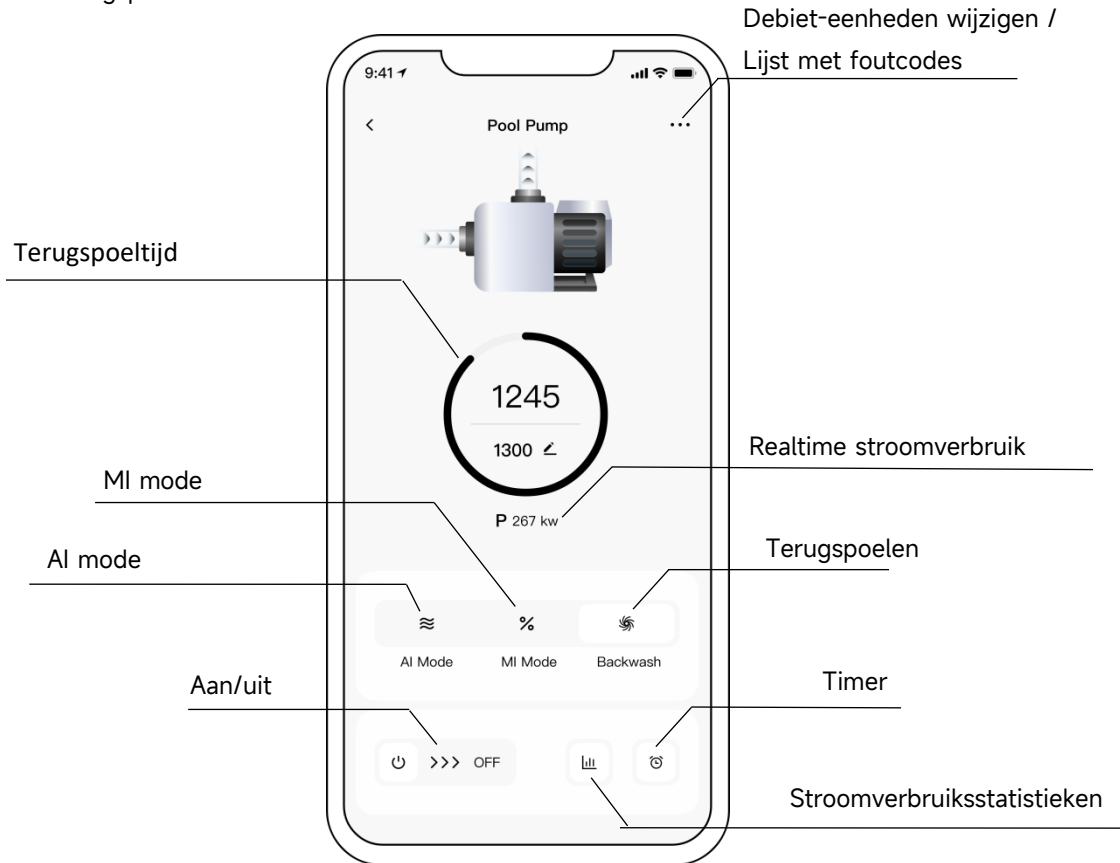

Let op bij het instellen van de timer via de APP:

- 1) De tijdsvariantie is $\pm 30s$;
- 2) Om te voorkomen dat overlappende timingpunten door netwerkvertraging met elkaar in conflict komen en ongeldig worden, wordt aanbevolen dat de eindtijd en de starttijd van de volgende timingperiode elkaar niet kunnen overlappen en dat er een voldoende groot tijdsinterval wordt gereserveerd, bijvoorbeeld minimaal 2 minuten;

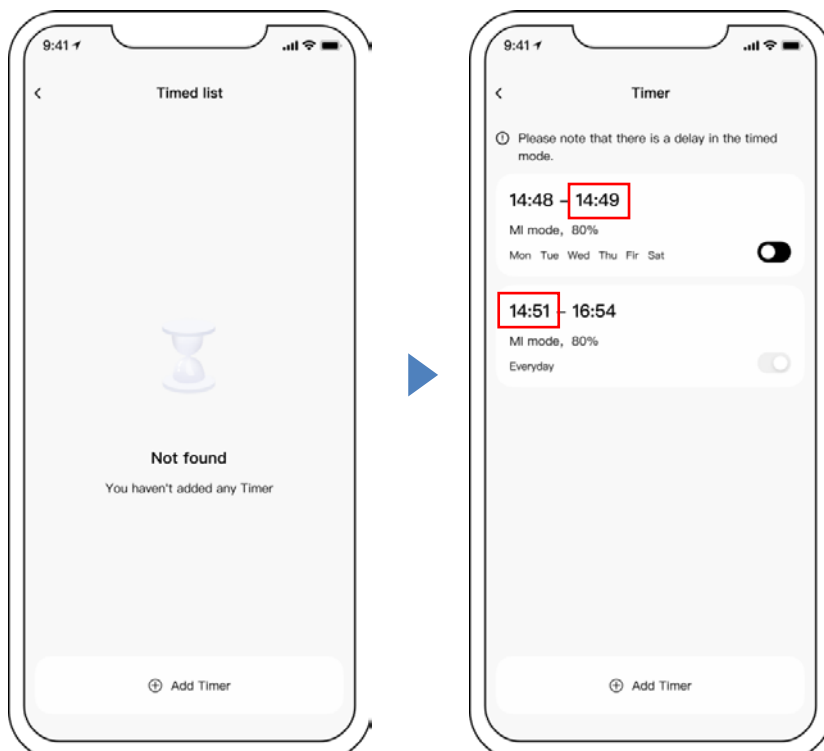

5 Apparaten delen met uw gezinsleden

Gebruikers kunnen de apparaten delen die hun familieleden kunnen bedienen. Laat uw familieleden eerst "iGarden" registreren, waarna de beheerder als volgt te werk kan gaan:

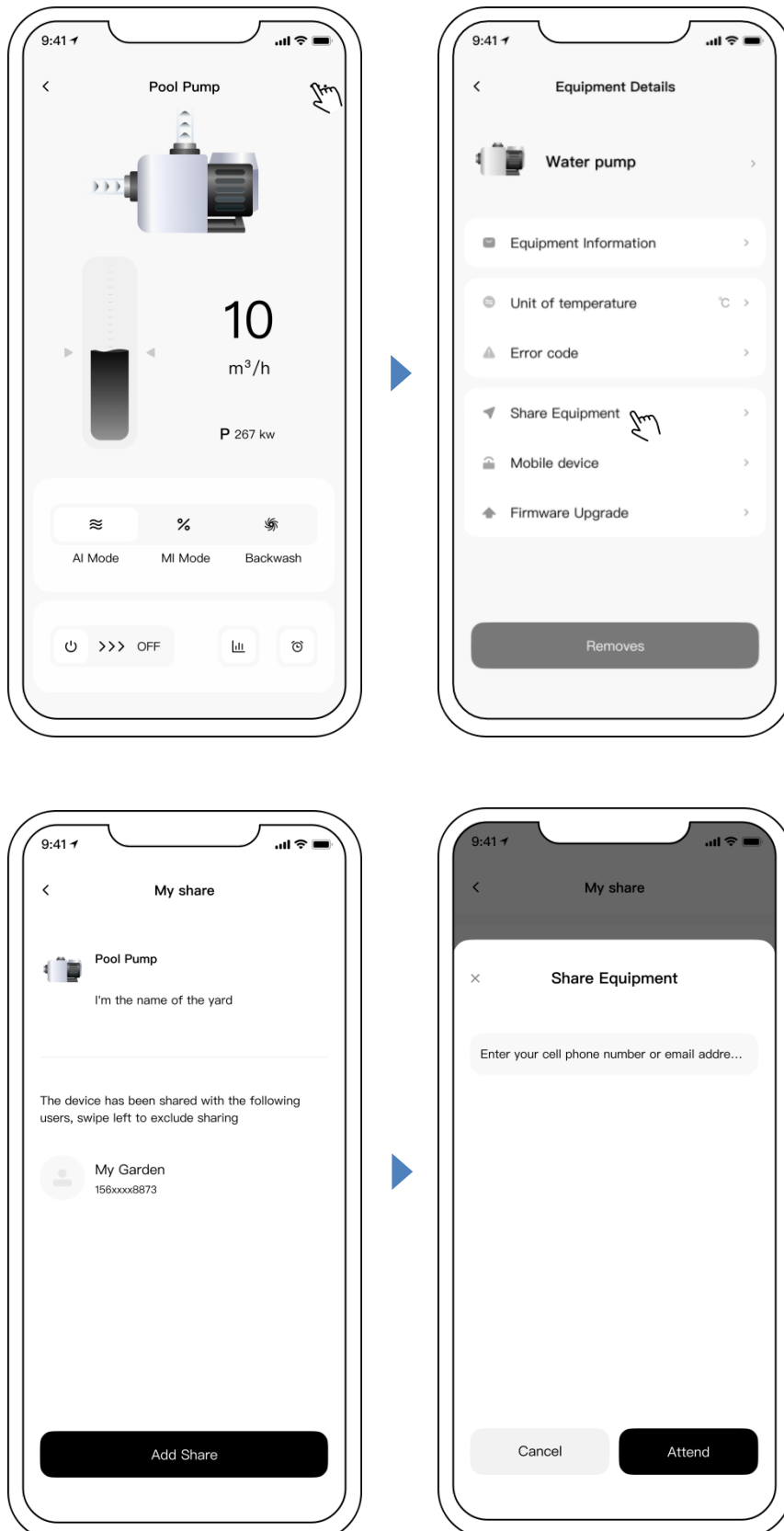

6 Tuinbeheer

In de apparatenlijst wordt de huidige binnenplaats weergegeven. Na het klikken kunnen gebruikers alle huidige binnenplaatsen bekijken/ernaar schakelen, op Tuinbeheer klikken en ook de pagina met de binnenplaatsenlijst openen. Zoals hieronder weergegeven:

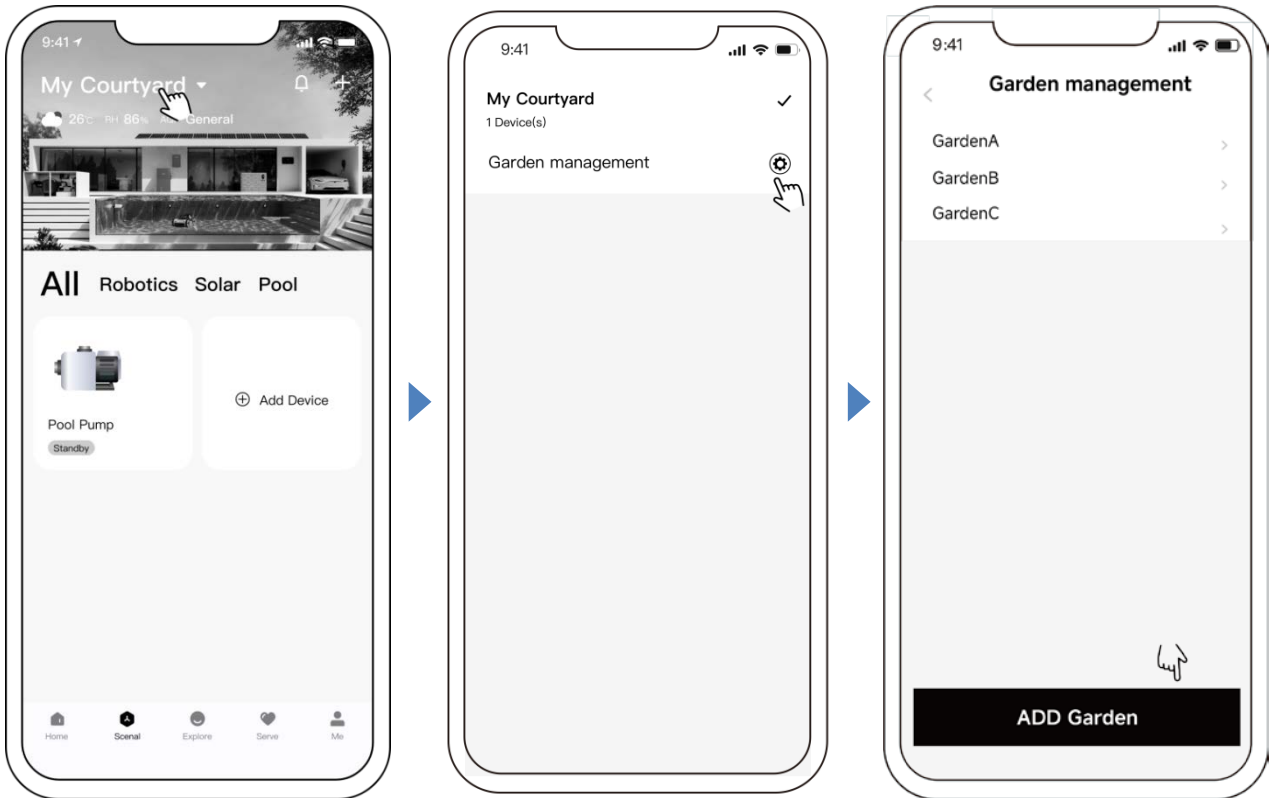

7 Berichtencentrum

A: Bericht bekijken: Klik op de pagina met de apparatenlijst op het berichtenpictogram om het berichtencentrum te openen en het bijbehorende bericht te bekijken, zoals hieronder weergegeven: (Inclusief: Alarm, Tuin, Melden)

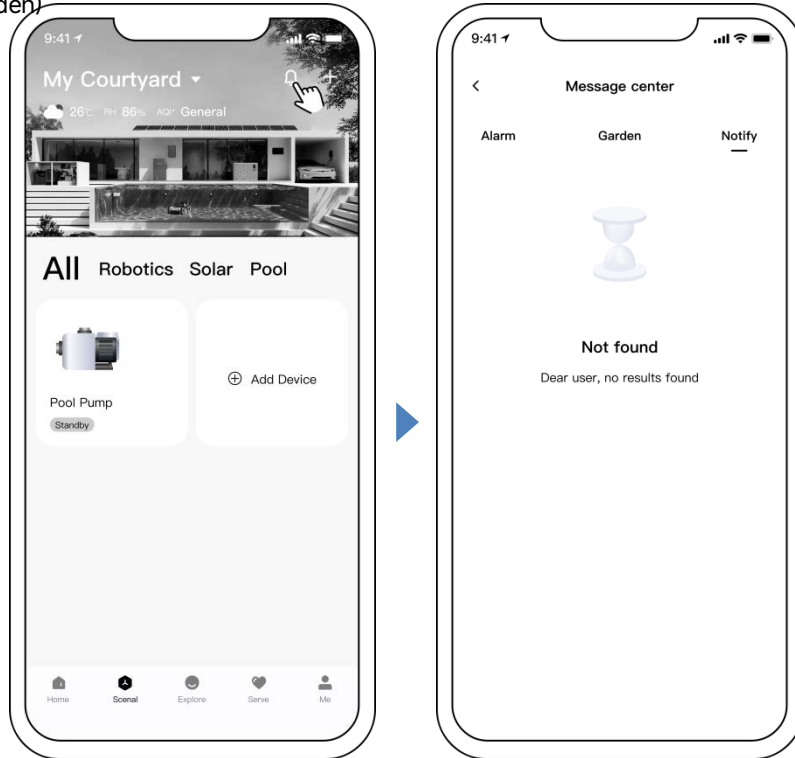

B: Push-instellingen: Klik op de pagina 'Instellingen' op [Push-instellingen] om de pagina 'Push-instellingen' te openen. Gebruikers kunnen de push-instellingen instellen op basis van de berichtclassificatie, zoals hieronder weergegeven:

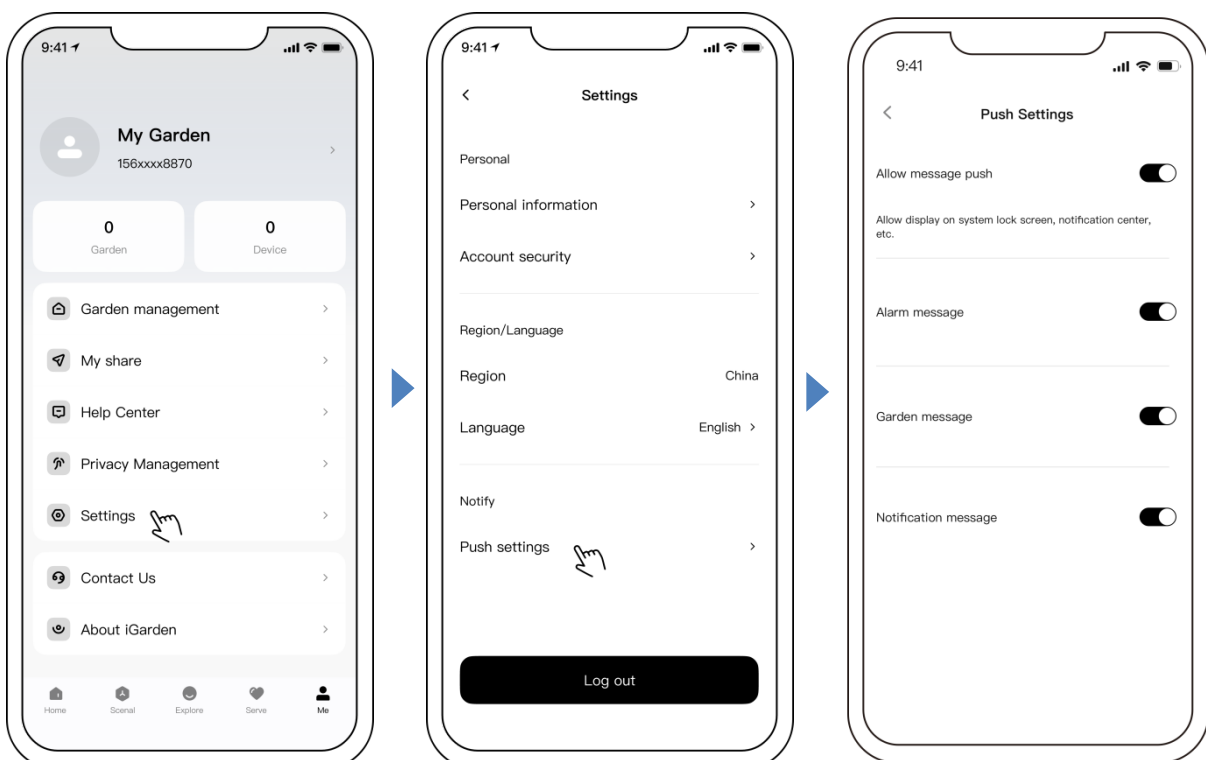

Als u problemen ondervindt tijdens het gebruik, kunt u ons feedback sturen. De procedure is als volgt:

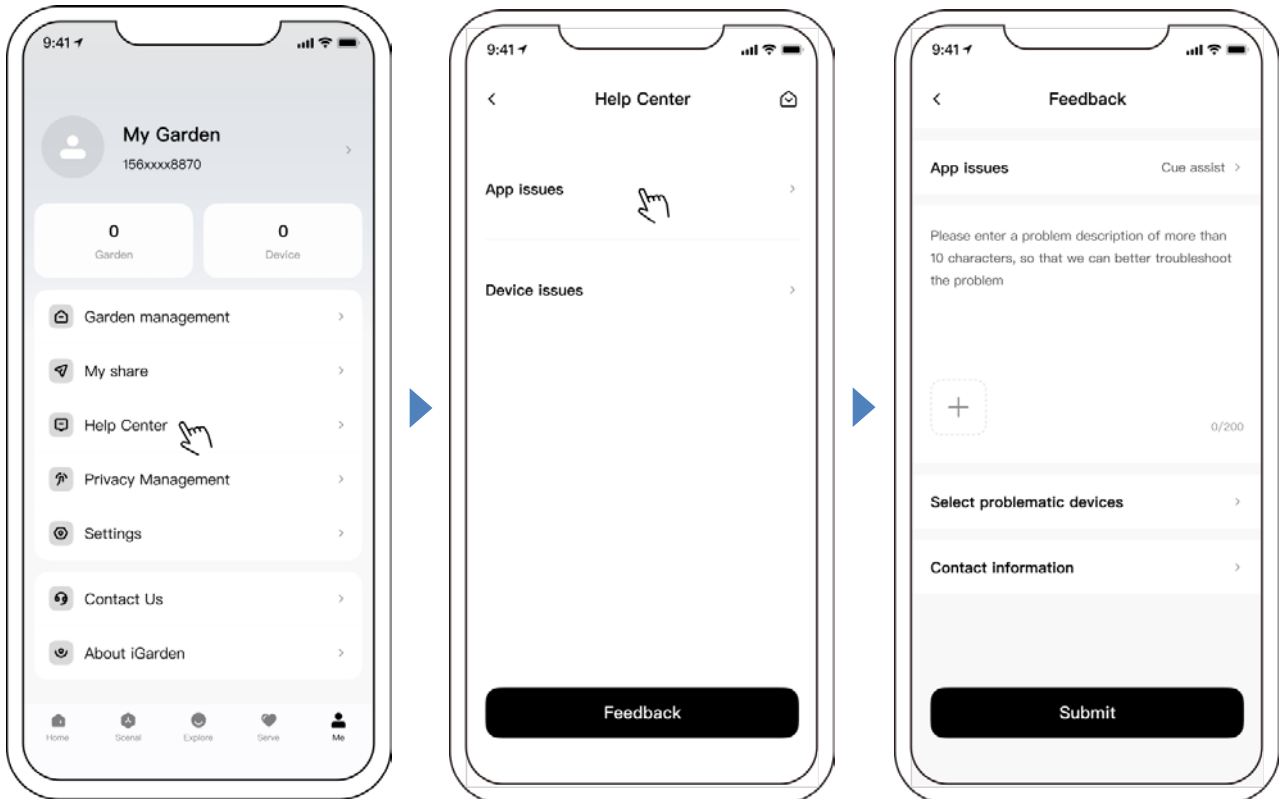

Kennisgeving:

- 1) De weersvoorspelling is slechts ter referentie;
- 2) De gegevens over het stroomverbruik dienen uitsluitend ter referentie, omdat ze kunnen worden beïnvloed door netwerkproblemen en onnauwkeurigheden in de berekening;
- 3) De app kan zonder voorafgaande kennisgeving worden bijgewerkt.

7. EXTERNE CONTROLE

Externe bediening kan worden ingeschakeld via de volgende contacten. Als er meer dan één externe bediening is ingeschakeld, is de prioriteit als volgt: Digitale ingang > RS485 > Paneelbediening

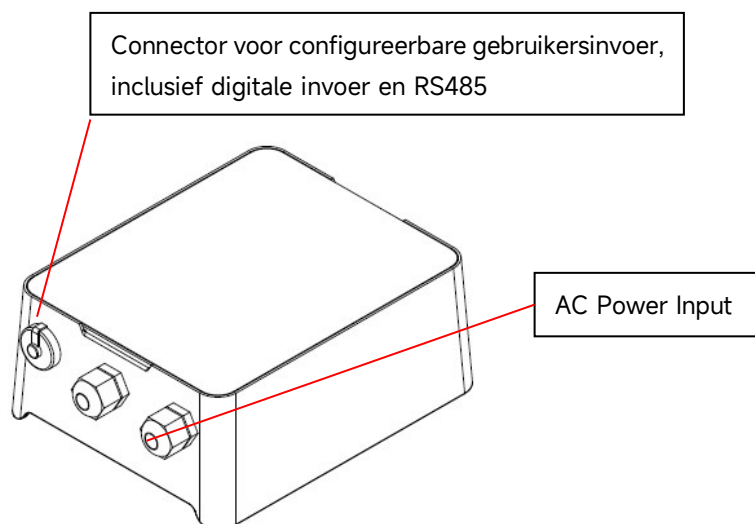

Figuur 5 - Locatie van de connectorpoort

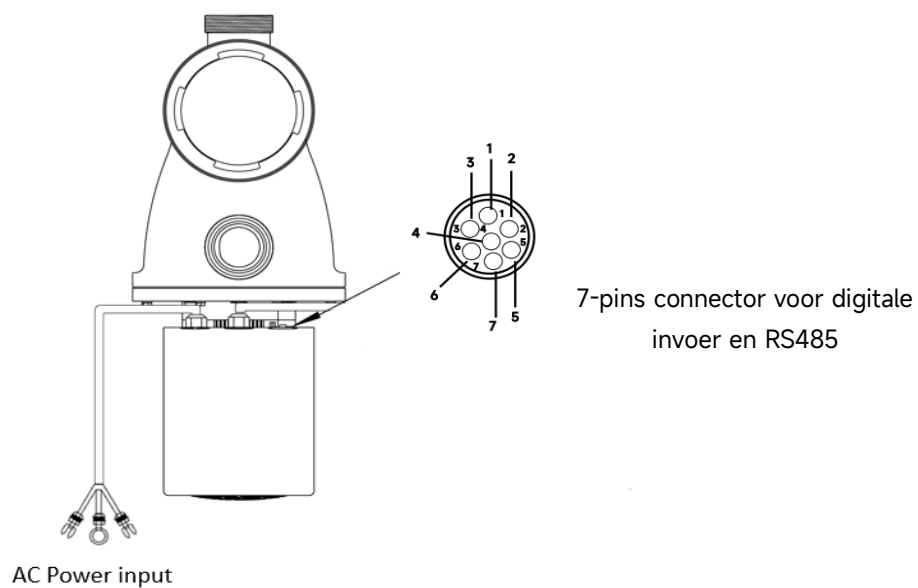

Figuur 6 - Connector voor digitale invoer en RS485

AC-voeding (geschikt voor 115V en 230V)

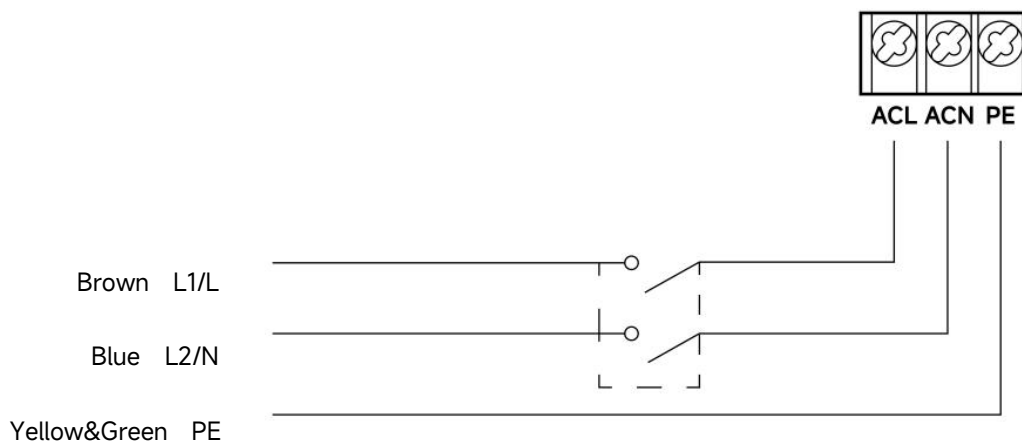

Figuur 7 - Aansluiting van het netsnoer

Externe controle	Kleur	Beschrijving	Opmerking
Digitale ingang	Rood	Di4 (digitale ingang 4)	Standaardsnelheid = 40%
	Zwart	Di3 (digitale ingang 3)	Standaardsnelheid = 80%
	Wit	Di2 (digitale ingang 2)	Standaardsnelheid = 100%
	Grijs	Di1 (digitale ingang 1)	Stop
	Geel	Digitale Grond (COM)	COM
RS485	Groente	RS485-A	/
	Bruin	RS485-B	/

a. Digitale ingang

De werkingscapaciteit wordt bepaald door de status van de digitale ingang,

1. Wanneer Di1 (grijs) is verbonden met COM (geel), moet de pomp verplicht stoppen. Indien losgekoppeld, is de digitale besturing ongeldig.
2. Wanneer Di2 (wit) is aangesloten op COM (geel), moet de pomp verplicht op 100% draaien. Indien losgekoppeld, wordt de regelprioriteit weer op de paneelregeling ingesteld.
3. Wanneer Di3 (zwart) is verbonden met COM (geel), moet de pomp verplicht op 80% draaien. Indien losgekoppeld, wordt de regelprioriteit weer op de paneelregeling ingesteld.
4. Wanneer Di4 (rood) is verbonden met COM (geel), moet de pomp verplicht op 40% draaien. Indien losgekoppeld, wordt de regelprioriteit weer op de paneelregeling ingesteld.
5. De capaciteit van de ingangen (Di2/Di3/Di4) kan worden aangepast op basis van de parameterinstelling.

b. RS485

Om verbinding te maken met RS485-A (groen) en RS485-B (bruin) kan de pomp worden aangestuurd via het Modbus 485-communicatieprotocol.

8.BESCHERMING EN FALEN

8.1 voor hoge temperaturen en snelheidsverlaging - AL01

In "Auto Omvormer/Handleiding Invertermodus en timermodus (behalve backwash/zelfaanzuiging): wanneer de moduletemperatuur de drempelwaarde voor de waarschuwing voor hoge temperaturen (81 °C) bereikt, gaat de module over naar de waarschuwingsstatus voor hoge temperaturen . Wanneer de temperatuur daalt tot de drempelwaarde voor de waarschuwing voor hoge temperaturen (78 ° C), wordt de waarschuwingsstatus voor hoge temperaturen vrijgegeven. Het display geeft afwisselend AL01 en de bedrijfssnelheid of debiet weer .

Als AL01 wordt weergegeven, wordt de bedrijfscapaciteit automatisch als volgt verlaagd:

- 1) Indien de huidige operationele capaciteit hoger is dan 100 %, wordt de operationele capaciteit automatisch teruggebracht tot 85% ;
- 2) Indien de huidige operationele capaciteit tussen 85% en 100% ligt, wordt de operationele capaciteit automatisch met 15% verminderd;
- 3) Indien de huidige operationele capaciteit tussen 70% en 85% ligt, wordt de operationele capaciteit automatisch met 10% verminderd;
- 4) Indien de huidige operationele capaciteit lager is dan 70%, wordt de operationele capaciteit automatisch met 5% verminderd.

8.2 Onderspanningsbeveiliging - AL02

Het apparaat is compatibel met zowel 230V als 115V AC-voeding .

① AC-stroomingang: 230V

Wanneer het apparaat detecteert dat de ingangsspanning lager is dan 198 V, beperkt het de huidige snelheid. Het display toont afwisselend AL02 en de snelheid of stroom.

- 1) Wanneer de ingangsspanning lager of gelijk is aan 180V, wordt de bedrijfscapaciteit beperkt tot 70%;
- 2) Wanneer het ingangsspanningsbereik binnen 180V - 190V ligt, wordt de bedrijfscapaciteit beperkt tot 75%;
- 3) Wanneer het ingangsspanningsbereik binnen 190V - 198V ligt, wordt de bedrijfscapaciteit beperkt tot 85% .

② AC-stroomingang: 115V

Wanneer het apparaat detecteert dat de ingangsspanning lager is dan 98 V, beperkt het de huidige snelheid. Het display toont afwisselend AL02 en de snelheid of stroom.

- 1) Wanneer het ingangsspanningsbereik binnen 85V - 90V ligt, wordt de bedrijfscapaciteit beperkt tot 75%;
- 2) Wanneer het ingangsspanningsbereik binnen 90V - 98V ligt, wordt de bedrijfscapaciteit beperkt tot 85% .

Let op: Als de ingangsspanning lager is dan 85 V, wordt foutcode E001 (Abnormale ingangsspanning, zie 8.4) weergegeven.

8.3 Probleemoplossing

Probleem	Mogelijke oorzaken en oplossingen
Pomp start niet	<ul style="list-style-type: none"> • Storing in de voeding, losgekoppelde of defecte bedrading. • Zekeringen zijn doorgebrand of er is sprake van thermische overbelasting. • Controleer of de motoras vrij kan bewegen en niet geblokkeerd is. • Vanwege langdurige stilstand. Haal de stekker uit het stopcontact en draai de achterste as van de motor handmatig een paar keer rond met een schroevendraaier.
Pomp zuigt niet aan	<ul style="list-style-type: none"> • Leeg de pomp-/zeefbehuizing. Zorg ervoor dat de pomp-/zeefbehuizing gevuld is met water en dat de O-ring van het deksel schoon is. • Losse verbindingen aan de zuigzijde. • Zeefmand of skimmermand gevuld met vuil. • Zuigzijde verstopt. • Als de afstand tussen de pompinlaat en het vloeistofniveau groter is dan 2 m, moet de installatiehoogte van de pomp worden verlaagd.
Lage waterstroom	<ul style="list-style-type: none"> • De pomp zuigt niet aan. • Lucht die de aanzuigleiding binnenkomt. • Mand vol puin. • Onvoldoende waterpeil in het zwembad.
Pomp maakt lawaai	<ul style="list-style-type: none"> • Lucht lekkage in de aanzuigleiding, cavitatie veroorzaakt door een beperkte of te kleine aanzuigleiding of lekkage bij een verbinding, laag waterpeil in het zwembad en onbelemmerde afvoerretourleidingen. • Trillingen veroorzaakt door onjuiste installatie, etc. • Beschadigd motorlager of waaier (neem contact op met de leverancier voor reparatie).

8.4 Foutcode

Wanneer het apparaat een storing detecteert, stopt het automatisch en wordt de foutcode weergegeven . Controleer na 15 seconden of de storing is verholpen . Als dit is opgelost, zal de pomp weer werken .

Item	Foutcode	Details	
1	E001	Beschrijving	Abnormale ingangsspanning : De voedingsspanning ligt buiten het bereik van 165V tot 275V .
		Proces	De pomp stopt automatisch gedurende 15 seconden en gaat weer werken als hij detecteert dat de voedingsspanning binnen het bereik valt.
2	E002	Beschrijving	Overstroom bij uitvoer : De piekstroom van de pomp is hoger dan de beveiligingsstroom.

		Proces	De pomp stopt automatisch gedurende 15 seconden en daarna hervat het werk . Als dit drie keer achter elkaar gebeurt, wordt de pomp uitgeschakeld en moet deze worden gecontroleerd en handmatig opnieuw opgestart .
3	E102	Beschrijving	Koellichaam Fout: De temperatuur van het koellichaam bereikt 91 °C gedurende 10 seconden . Of de sensor van het koellichaam detecteert een open circuit of kortsluiting .
		Proces	1. De pomp stopt automatisch gedurende 30 seconden en hervat de werking als hij detecteert dat de temperatuur van het koellichaam lager is dan 81 °C. 2. De pomp stopt automatisch gedurende 15 seconden en hervat de werkzaamheden als het detecteert dat de sensor van het koellichaam niet open is of kortsluiting veroorzaakt .
4	E103	Beschrijving	Master driver board fout: De Hoofdbestuurdersbord is defect.
		Proces	De pomp stopt automatisch gedurende 15 seconden en daarna hervat het werk . Als dit drie keer achter elkaar gebeurt, wordt de pomp uitgeschakeld en moet deze worden gecontroleerd en handmatig opnieuw opgestart .
5	E104	Beschrijving	Fase-deficiënte beveiliging: De motorkabels zijn niet aangesloten op de master -aandrijfkaart .
		Proces	De pomp stopt automatisch gedurende 15 seconden en daarna hervat het werk . Als dit drie keer achter elkaar gebeurt, wordt de pomp uitgeschakeld en moet deze worden gecontroleerd en handmatig opnieuw opgestart .
6	E203	Beschrijving	- tijdsleesfout : Lezen en schrijven De informatie op de timerklok is onjuist .
		Proces	De pomp moet handmatig worden uitgeschakeld en opnieuw worden opgestart.
7	E204	Beschrijving	van het EEPROM-displaybord : Lezen en schrijven de informatie van EEPROM van displaybord is onjuist .
		Proces	De pomp moet handmatig worden uitgeschakeld en opnieuw worden opgestart.
8	E205	Beschrijving	Communicatiefout : De communicatiefout tussen displaybord en master driverbord duurt 15 sec.
		Proces	De pomp stopt automatisch gedurende 15 seconden en hervat de werking als het detecteert dat de communicatie tussen het displaybord en het master driverbord 1 seconde duurt.

9	E207	Beschrijving	Geen waterbescherming : De pomp heeft geen water.
		Proces	Zet de pomp handmatig stil, vul de pomp met water en start hem opnieuw. Als dit twee keer achter elkaar gebeurt, wordt de pomp uitgeschakeld en moet u deze handmatig controleren .
10	E209	Beschrijving	Verlies van aanzuiging : De pomp kan niet zelf aanzuigen om redenen zoals het overschrijden van het aanzuigbereik of het te complex zijn van de pijpleiding.
		Proces	Controleer de pomp of de leiding op lekkages. Vul de pomp vervolgens met water en start deze opnieuw.

9.ONDERHOUD

Leeg het zeefmandje regelmatig. Inspecteer het mandje door het transparante deksel en leeg het wanneer er een duidelijke stapel afval in zit. Volg de volgende instructies:

- 1). De stroomtoevoer is losgekoppeld.
- 2). Draai het deksel van het zeefmandje tegen de klok in los en verwijder het.
- 3). Til het zeefmandje omhoog.
- 4). Leeg het opgevangen vuil uit de mand en spoel het vuil er indien nodig uit.

Let op: stoot de plastic mand niet op een hard oppervlak, omdat dit schade kan veroorzaken

- 5). Controleer de mand op tekenen van schade en vervang deze.
- 6). Controleer de O-ring van het deksel op uitrekken, scheuren, barsten of andere schade
- 7). Plaats het deksel terug, met de hand vastdraaien is voldoende.

Let op: Regelmatige inspectie en reiniging van het zeefmandje verlengt de levensduur ervan.

10.GARANTIE & UITSLUITINGEN

Mocht er tijdens de garantieperiode een defect aan het licht komen, dan zal de fabrikant, naar eigen goeddunken, het betreffende artikel of onderdeel op eigen kosten repareren of vervangen. Klanten dienen de garantieclaimprocedure te volgen om aanspraak te kunnen maken op deze garantie.

De garantie vervalt bij een verkeerde installatie, een verkeerde bediening, oneigenlijk gebruik, manipulatie of gebruik van niet-originele reserveonderdelen.

11.BESCHIKBAARHEID



Wanneer u het product weggooit , scheidt u het afval als elektrisch of elektronisch afval of levert u het in bij het plaatselijke afvalinzamelpunt.

Gescheiden inzameling en recycling van afgedankte apparatuur draagt bij aan een recycling die de menselijke gezondheid en het milieu beschermt. Neem contact op met uw



gemeente voor informatie over waar u uw waterpomp kunt inleveren voor recycling.

CONTENUTO

1. ⚠️ IMPORTANTI ISTRUZIONI DI SICUREZZA	187
2. SPECIFICHE TECNICHE	188
3. DIMENSIONI TOTALI (mm)	188
4. INSTALLAZIONE	189
5. IMPOSTAZIONE E FUNZIONAMENTO	191
6. FUNZIONAMENTO WIFI (ARTICOLO OPZIONALE)	201
7. CONTROLLO ESTERNO	210
8. PROTEZIONE E GUASTO	212
9. MANUTENZIONE	215
10. GARANZIA ED ESCLUSIONI	216
11. SMALTIMENTO	216

GRAZIE PER AVER ACQUISTATO LE NOSTRE POMPE INVERTER PER PISCINE.

IL PRESENTE MANUALE CONTIENE INFORMAZIONI IMPORTANTI CHE VI AIUTERANNO NELL'UTILIZZO E NELLA MANUTENZIONE DI QUESTO PRODOTTO.

SI PREGA DI LEGGERE ATTENTAMENTE IL MANUALE PRIMA DELL'INSTALLAZIONE E DEL FUNZIONAMENTO E DI CONSERVARLO PER FUTURI RIFERIMENTI.

1. IMPORTANTI ISTRUZIONI DI SICUREZZA

Durante l'installazione e l'utilizzo di questa apparecchiatura elettrica, è necessario seguire sempre le precauzioni di sicurezza di base, tra cui le seguenti:

- 1) LEGGERE E SEGUIRE TUTTE LE ISTRUZIONI
- 2) ATTENZIONE – Per ridurre il rischio di lesioni, non consentire ai bambini di utilizzare questo prodotto se non sotto stretta sorveglianza in ogni momento.
- 3) AVVERTENZA – Rischio di scossa elettrica. Collegare solo a un circuito derivato protetto da un interruttore differenziale (RCD) con una corrente nominale di intervento residua non superiore a 30 mA. Se non è possibile verificare che il circuito sia protetto da un interruttore differenziale RCD, contattare un elettricista qualificato..
- 4) PER PREVENIRE IL RISCHIO DI SCOSSA ELETTRICA, collegare il cavo di terra del motore (verde/giallo) al sistema di messa a terra.
- 5) ATTENZIONE – Per ridurre il rischio di scosse elettriche, sostituire immediatamente il cavo danneggiato.
- 6) Non installare all'interno di una recinzione esterna o sotto la gonna di una vasca idromassaggio o di una spa.
- 7) Un sezionatore deve essere installato sull'impianto elettrico fisso in conformità con le norme di installazione.
- 8) Per l'uso in piscine, vasche idromassaggio e centri benessere.
- 9) ATTENZIONE: per ridurre il rischio di scosse elettriche, installare ad almeno 5 metri dalle pareti interne della piscina. Non utilizzare prolunghe.
- 10) ATTENZIONE: per garantire una protezione continua contro il rischio di scosse elettriche, utilizzare solo parti di ricambio identiche durante la manutenzione .
- 11) Questa pompa è progettata per l'uso con piscine interrato o fuori terra installate in modo permanente e può essere utilizzata anche con vasche idromassaggio e spa con una temperatura dell'acqua inferiore a 50 °C . A causa del metodo di installazione fisso, questa pompa non è consigliata per l'uso su piscine fuori terra che possono essere facilmente smontate per lo stoccaggio.
- 12) La pompa non è sommergibile
- 13) Non aprire mai l'interno dell'alloggiamento del motore di azionamento
- 14) CONSERVARE QUESTE ISTRUZIONI

ATTENZIONE:

- Riempire la pompa con acqua prima dell'avviamento. Non far funzionare la pompa a secco. In caso di funzionamento a secco, la tenuta meccanica verrà danneggiata e la pompa inizierà a perdere.
- Prima di effettuare la manutenzione della pompa, spegnere la pompa scollegando il circuito principale e rilasciare tutta la pressione dalla pompa e dal sistema di tubazioni.
- Non stringere o allentare mai le viti mentre la pompa è in funzione.
- Assicurarsi che l'ingresso e l'uscita della pompa siano liberi da corpi estranei.

2.SPECIFICHE TECNICHE

Modello	Volume piscina consigliato (m ³)	P1	Tensione (V/Hz)	Qmax (m ³ /h)	Altezza massima (m)	Circolazione (m ³ /h)	
		KW				A 10m	A 8m
DCP12	40-70	1.2	220-240/ 50/60	28.0	21.0	23.0	26.0

3.DIMENSIONE TOTALE (mm)



Figura 1 - Dimensioni della pompa

4.INSTALLAZIONE

4.1 Posizione della pompa

- 1) Installare la pompa il più vicino possibile alla piscina, per ridurre la perdita di carico per attrito e migliorare l'efficienza; utilizzare tubazioni di aspirazione e ritorno corte e dirette.
- 2) Per evitare l'esposizione diretta al sole, al calore o alla pioggia, si consiglia di posizionare la pompa all'interno o all'ombra.
- 3) NON installare la pompa in un luogo umido o non ventilato. Tenere la pompa e il motore ad almeno 150 mm di distanza da ostacoli; i motori delle pompe necessitano di una libera circolazione dell'aria per il raffreddamento.
- 4) La pompa deve essere installata orizzontalmente e fissata nel foro del supporto con viti per evitare rumori e vibrazioni inutili.

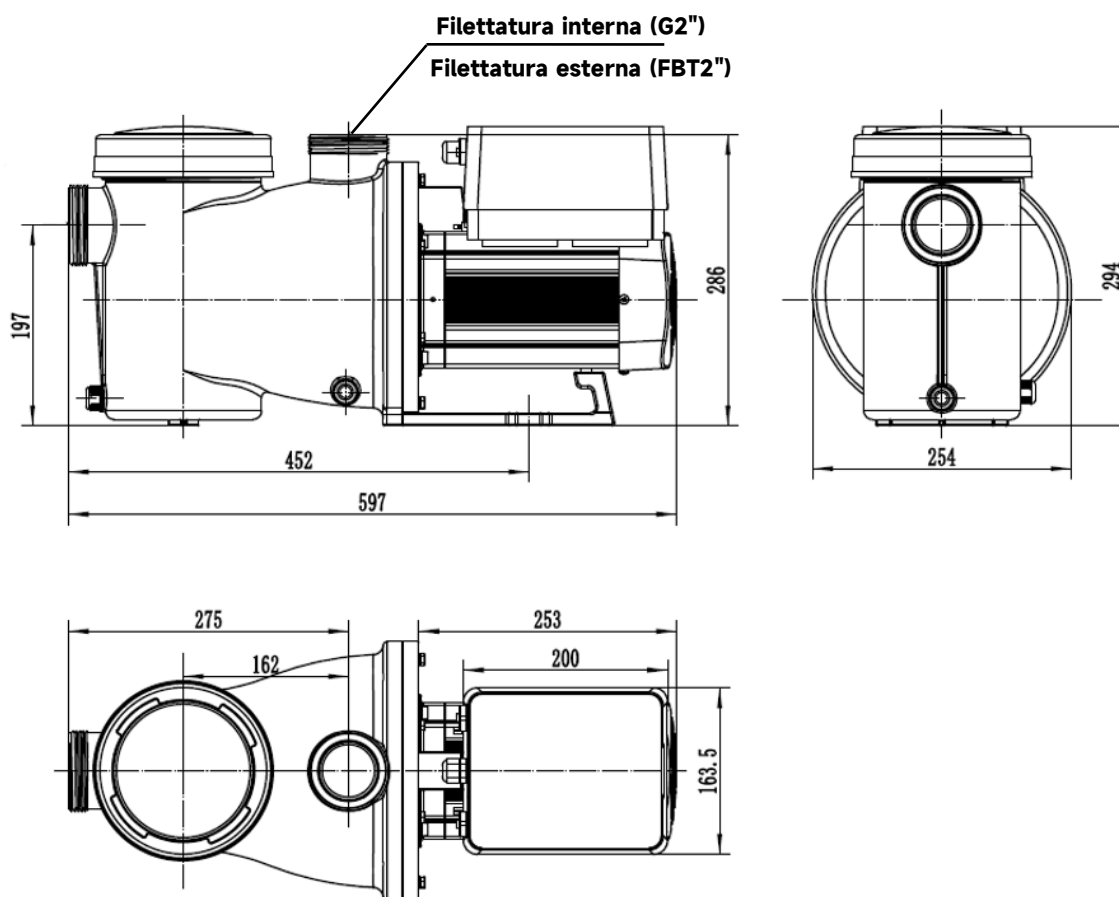
4.2 Impianti idraulici e valvole

- 1) Dimensioni del raccordo di ingresso/uscita della pompa: opzionale con sistema metrico (50 o 63 mm) o imperiale (1,5 " o 2") .
- 2) Per ottimizzare l'impianto idraulico della piscina, è consigliabile utilizzare tubi di diametro maggiore. Si consiglia di utilizzare tubi da 63mm.
- 3) Durante l'installazione dei raccordi di ingresso e di uscita (giunti) con le tubazioni, utilizzare il sigillante speciale per materiali in PVC.
- 4) La dimensione della linea di aspirazione deve essere uguale o maggiore del diametro della linea di ingresso, per evitare che la pompa aspiri aria, il che ne comprometterebbe l'efficienza.
- 5) Per ridurre la perdita di carico per attrito e migliorare l'efficienza, le tubazioni sul lato di aspirazione e di ritorno devono essere corte e dirette.
- 6) I sistemi di aspirazione allagati devono essere dotati di valvole installate sia sulla linea di aspirazione che su quella di ritorno della pompa, per agevolare la manutenzione ordinaria. Una valvola, un gomito o un raccordo a T installato sulla linea di aspirazione non deve trovarsi a una distanza dalla parte anteriore della pompa inferiore a sette volte il diametro della linea di aspirazione.
- 7) Utilizzare una valvola di ritegno nella linea di ritorno nei punti in cui vi è un'altezza significativa tra la linea di ritorno e l'uscita della pompa, per impedire alla pompa di subire l'impatto della ricircolazione del fluido e di un colpo d'ariete che ne arresti la pompa .

4.3 Raccordi

- 1) I gomiti non devono essere posizionati a meno di 350 mm dall'ingresso. Non installare gomiti a 90° direttamente nell'ingresso/uscita della pompa. I giunti devono essere a tenuta stagna.
- 2) Le giunzioni devono essere strette.



Figura 2 - Impianti idraulici e raccordi

* Dimensioni del raccordo di ingresso/uscita della pompa: opzionale con sistema metrico (50 o 63 mm) o imperiale (1,5 " o 2")

- 3) Utilizzare il KIT DI RACCORDO fornito dal produttore della pompa (vedere Figura 3). Non utilizzare altri raccordi per collegare l'ingresso/uscita della pompa, nel caso in cui i raccordi non siano compatibili e danneggino il corpo della pompa.

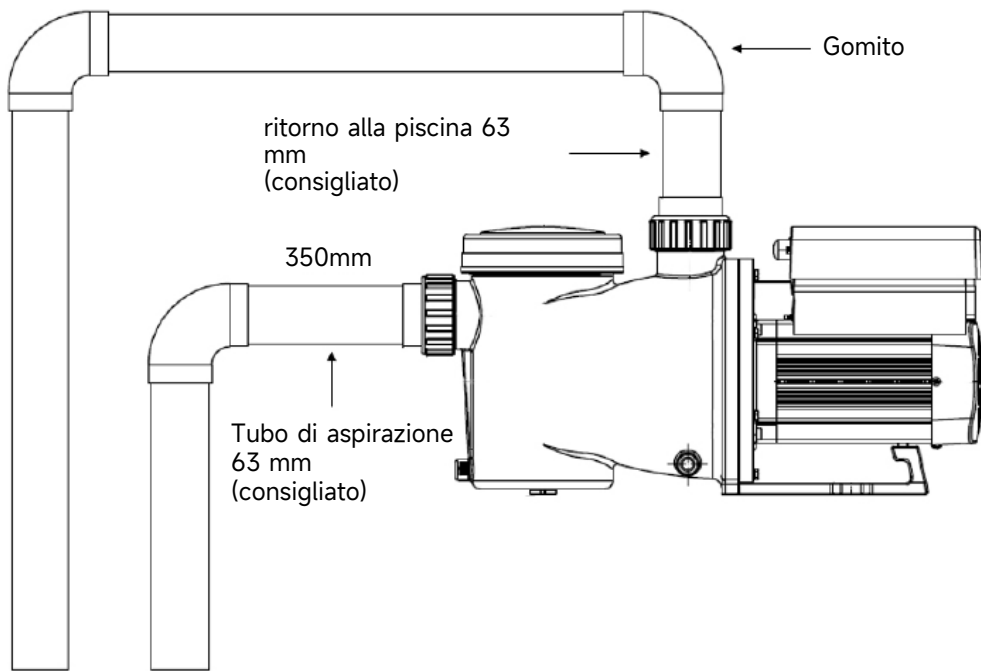

Figura 3 - Kit di unione

4.4 Controllare prima dell'avvio iniziale

- 1) Controllare se l'albero della pompa ruota liberamente;
- 2) Controllare che la tensione e la frequenza di alimentazione siano conformi a quanto indicato sulla targhetta;
- 3) Guardando la pala del ventilatore, la direzione di rotazione del motore dovrebbe essere in senso orario;
- 4) È vietato far funzionare la pompa senza acqua.

4.5 Condizioni di applicazione

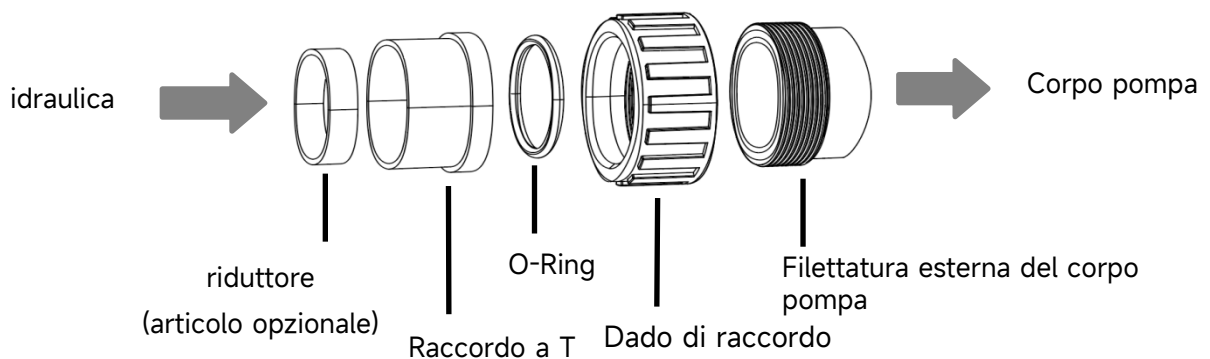
Temperatura ambiente	Installazione interna, intervallo di temperatura: -10-42°C
Temperatura massima dell'acqua	50°C
Acqua salata disponibile	Concentrazione di sale fino al 3,5%, ovvero 35 g/l
Umidità	≤90% UR, (20°C±2°C)
Installazione	La pompa può essere installata al massimo a 2 m sopra il livello dell'acqua
Protezione	Classe F, IP55

5. IMPOSTAZIONE E FUNZIONAMENTO



5.1 Display sul pannello di controllo

	1. Consumo energetico
	2. Capacità di funzionamento / Portata
	3. Indicatore WIFI (elemento opzionale)
	4. Unità di flusso
	5. Periodo del timer
	6. Timer 1/2/3/4
	Lavaggio/sblocco
	Su/giù: per modificare il valore dell'impostazione
	Passa da Manuale Modalità inverter e Auto Modalità inverter. Manuale Modalità inverter : La capacità di funzionamento verrà impostata manualmente tra il 30% e l' 1,20 %. Auto Modalità inverter : la capacità di funzionamento verrà regolata automaticamente tra il 30% e l' 1,2 % in base alla portata preimpostata. La modalità predefinita è Manuale Invertitore modalità.
	Impostazione del timer
Acceso/spento	

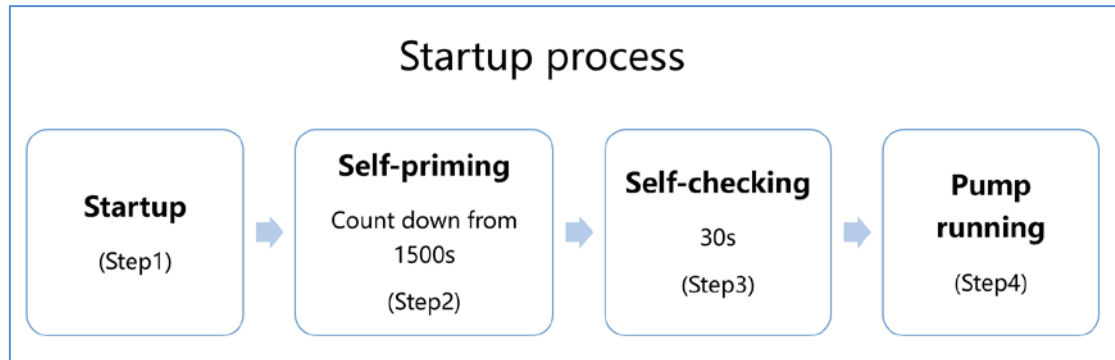
5.2 Avvio processo panoramica



① Fase 1 : Avvio

- Tenere premuto  per più di 3 secondi per sbloccare lo schermo .
- Premere  A avvio IL pompa.

② Fase 2 : Autoadescamento

- IL pompa inizierà conto alla rovescia da 1500 s ; quando il sistema rileva che la pompa è piena d'acqua, interrompe il conto alla rovescia e esce automaticamente dalla modalità di adescamento.
- Gli utenti possono immettere l'impostazione dei parametri per disattivare la funzione di autoadescamento predefinita (vedere 5.11) .



③ Fase 3 : Autocontrollo

- IL pompa verrà effettuato un nuovo controllo per 30 secondi per assicurarsi che l'autoadescamento (fase 2) sia completato .

④ Fase 4 : Pompa corsa

- dopo l'autoadescamento, la pompa funzionerà all'80% della sua capacità di esercizio .

5.3 Avvio

Quando l'alimentazione è accesa, lo schermo si illumina completamente per 3 secondi, verrà visualizzato il codice del dispositivo e quindi entrerà nel normale stato di funzionamento. Quando lo schermo è bloccato, solo il pulsante  si illuminerà; tenere premuto  per più di 3 secondi per sbloccare lo schermo. Lo schermo si bloccherà automaticamente se non viene eseguita alcuna operazione per più di 1 minuto e la luminosità dello schermo verrà ridotta a 1/3 della visualizzazione normale. Premere brevemente  per riattivare lo schermo e osservare i relativi parametri operativi.

5.4 Autoadescante

Ogni volta che la pompa viene avviata, inizierà l'autoadescamento.

Quando la pompa funziona autoadescante, inizierà il conto alla rovescia da 1500 secondi e interrompe automaticamente il conto alla rovescia quando il sistema rileva che la pompa è piena d'acqua, quindi il sistema eseguirà un nuovo controllo per 30 secondi per assicurarsi che l'autoadescamento sia completato.

L'utente può annullare manualmente l'autoadescamento premendo  per più di 3 secondi. La pompa entrerà nella modalità Inverter manuale predefinita all'avvio iniziale.



Nota:

La pompa viene consegnata con l'autoadescamento abilitato. Ogni volta che la pompa si riavvia, eseguirà automaticamente l'autoadescamento. L'utente può accedere all'impostazione dei parametri per disabilitare la funzione di autoadescamento predefinita (vedere 5.11).

5.5 lavaggio a controcorrente

L'utente può avviare il controlavaggio o la ricircolazione rapida in qualsiasi stato di funzionamento premendo













	Predefinito	Intervallo di impostazione
Tempo	anni '80	Premere  o  per regolare da 0 a 1500 secondi con 30 secondi per ogni passo
Capacità di esecuzione	100%	60-100%, immettere l'impostazione del parametro (vedere 5.11)

Uscita controlavaggio:

Quando la modalità controlavaggio è attiva, gli utenti possono tenere premuto  per 3 secondi per annullarla; la pompa tornerà allo stato precedente al controlavaggio. Se l'utente ha impostato un limite di velocità, la capacità di funzionamento del controlavaggio non supererà il limite di velocità impostato. (vedere 5.10)

5.6 Manuale Modalità inverter









1		Tenere premuto  per più di 3 secondi per sbloccare lo schermo .
2		Premere  per avviare. La pompa funzionerà all'80% della capacità di esercizio all'avvio iniziale dopo l'autoadescamento.
3	 	Premere  o  per impostare la capacità di funzionamento tra il 30% e il 120%, con incrementi del 5% .
4		Premere  nuovamente per passare alla modalità Auto Inverter.





Nota :

- 1) Quando la pressione della tubazione è elevata, per mantenere una portata adeguata, l'utente può impostare la capacità di funzionamento al 105%-120%. La pompa funzionerà a una velocità maggiore per contrastare l'elevata pressione della tubazione.
- 2) Nell'intervallo compreso tra il 105% e il 120% della capacità di funzionamento, la pompa regolerà automaticamente la velocità quando raggiunge la potenza massima.
- 3) Ad esempio, quando l'utente regola la velocità al 110 %, se la pompa la potenza ha raggiunto il valore massimo a questa velocità , in questo momento, anche se l'utente continua ad aumentare la velocità della pompa al 120% , la pompa manterrà la velocità alla massima potenza, ovvero 110 %. E la velocità visualizzata scenderà dal 120% al 110%.

5.7 Auto Modalità inverter

In modalità Auto Inverter, la pompa può rilevare automaticamente la pressione del sistema e regolare la velocità del motore per raggiungere la portata impostata.

1		Sbloccare lo schermo, premere  per passare dalla modalità Inverter manuale alla modalità Inverter automatico.
2	 	La portata può essere regolata premendo  o  con 1 m ³ /h per ogni passaggio.
3	 	L'unità di portata può essere modificata in L /min , IMP gpm o US gpm , premendo

		entrambi i tasti   per 3 secondi .
4		Premere  per passare alla modalità Inverter manuale .

L' intervallo di portata regolabile predefinito per InverK è il seguente :

Modello	Intervallo di portata regolabile *
DCP12-IG	8-25 m ³ /h

*** Nota :**











In modalità Auto Inverter, la portata massima regolabile si basa su una prevalenza di circa 8 m.

Se gli utenti impostano il flusso alla massima portata regolabile e la pressione della tubazione è superiore a 8 m, in questa situazione la pompa aumenterà automaticamente la velocità di funzionamento e la potenza in ingresso per contrastare l'alta pressione e mantenere la massima portata impostata dagli utenti.





Quando la velocità del motore e la potenza in ingresso aumentano fino al livello massimo, ma non è sufficiente a contrastare l'enorme pressione della tubazione, il flusso visualizzato sul controller della pompa scenderà dal flusso impostato al flusso effettivamente ottenibile .

5.8 Modalità timer

L'accensione/spegnimento e la capacità di funzionamento della pompa potrebbero essere comandati da un timer, programmabile quotidianamente secondo necessità.

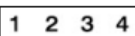
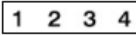

1	Accedere all'impostazione del timer premendo 
2	Premere  o  per impostare l'ora locale
3	Premere  per confermare e passare all'impostazione dell'ora 1
4	Premere  o  per scegliere i periodi di funzionamento desiderati , la capacità di funzionamento o la portata (quando l'icona % lampeggia, gli utenti possono modificare l'impostazione della portata premendo )
5	 Ripetere i passaggi precedenti per impostare il altri 3 timer
6	 Tenere premuto per 3 secondi per salvare l'impostazione e attivare la modalità timer
7	 oppure  controlla 4 timer per assicurarti che non ci siano impostazioni non valide



Nota:

1. Se il periodo di tempo impostato contiene l'ora corrente, la pompa inizierà a funzionare in base alla capacità di funzionamento o alla portata impostata, l'indicatore del timer corrente  (1 o 2 o 3 o 4) si accenderanno e l'area **88:88 - 88:88** visualizzerà il periodo di tempo corrispondente.
2. Se il periodo di tempo impostato non contiene l'ora corrente, il numero del timer  (1 o 2 o 3 o 4) che sta per iniziare a funzionare verrà visualizzato e lampeggerà, e l'area **88:88 - 88:88** visualizzerà il periodo di tempo corrispondente.
3. Durante l'impostazione del timer, se si desidera tornare all'impostazione precedente, tenere premuti entrambi i pulsanti   per 3 secondi. Se non è necessario impostare tutti e 4 i timer, è possibile tenere premuto  per 3 secondi: il sistema salverà automaticamente il valore impostato corrente e attiverà la modalità timer.
4. Le impostazioni del timer della pompa sono state limitate, gli utenti non imposteranno timer sovrapposti.
5. Dopo aver impostato il timer e aver spento la pompa, quando la si riaccende, questa tornerà alla modalità timer.
6. Gli utenti possono annullare la modalità timer premendo .

5.9 Schiumatoio Modalità

La modalità skimmer consente alla pompa di sfiorare la superficie dell'acqua, impedendo l'accumulo di detriti e garantendo agli utenti una piscina più pulita.

Tenere premuto  e  per accedere all'interfaccia preimpostata della modalità skimmer. Quando si passa per la prima volta a questa modalità, verrà attivato il preset 1.

Gli utenti possono premere  o  per visualizzare i 4 preset; i dettagli di ciascun preset sono riportati di seguito; il preset selezionato verrà attivato dopo 5 secondi di inattività.

Prereset	Ciclo di skimmer	Durata dello skimmer	Velocità di skimmer	Periodo di tempo	Osservazione
1	1 ora	3 minuti	100%	7:00 – 21:00	Modificabile in impostazione dei parametri
2	1 ora	10 minuti	100%	7:00 – 21:00	Non modificabile
3	3 ore	3 minuti	80%	7:00 – 21:00	Non modificabile
4	Disattivare la modalità skimmer				Non modificabile

Tabella 1 - Impostazioni predefinite

Durante la durata dello skimmer, il controller visualizzerà il parametro del preset, l'utente può tenere

premutato  per 3 secondi per annullare ogni volta la durata dello skimmer. Al termine della durata dello skimmer, la pompa tornerà allo stato normale per consentire all'utente di utilizzarla.

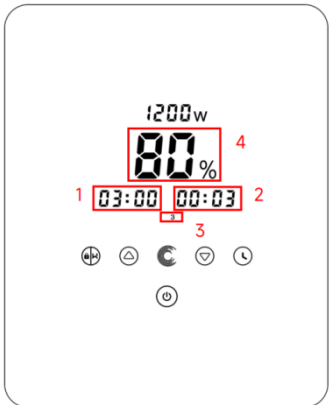
	<ol style="list-style-type: none"> 1. Ciclo dello skimmer (ora) 2. Durata dello skimmer (minuti) 3. Numero di preselezione della modalità dello skimmer 4. Velocità dello skimmer / portata
--	---



Figura 4 - Ciclo dello skimmer

5.10 Limite di velocità /flusso

Gli utenti possono impostare il limite di velocità /portata della pompa per soddisfare i requisiti di portata di altre apparecchiature, come i filtri a sabbia.



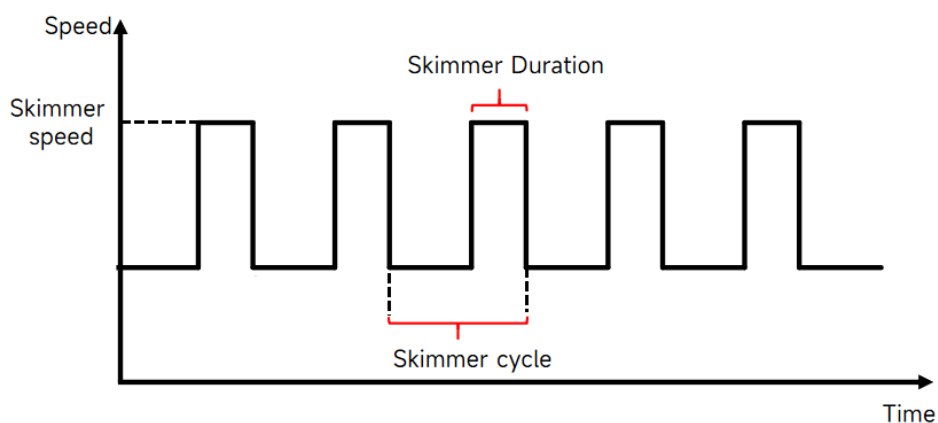



Il limite di velocità / portata della pompa può essere impostato nell'impostazione dei parametri. (vedere 5.11)



100% significa nessun limite di velocità e la capacità di funzionamento può essere impostata dal 30% al 120% in condizioni di funzionamento normale.



Modello	Limite di velocità/flusso	
	Velocità massima di corsa	Portata massima
DCP12-IG	60%~100%	15-25 m ³ /h



Per garantire le prestazioni, il processo di autoadescamento ad ogni avvio non sarà limitato dalla funzione di limitazione della velocità /portata .

5.11 Impostazione dei parametri

Ripristina le impostazioni di fabbrica	Spegnere la pompa, quindi tenere premuti entrambi i pulsanti   per 3 secondi
Controllare la versione del software	Spegnere la pompa, quindi tenere premuti entrambi i pulsanti   per 3 secondi
Inserire l'impostazione dei parametri come di seguito	Spegnere la pompa, quindi tenere premuti entrambi i pulsanti   per 3 secondi;

	Premere  per selezionare l'indirizzo del parametro e premere  o  per regolare l'impostazione del parametro.
--	---

Parametro Indirizzo	Descrizione	Impostazione predefinita	Intervallo di impostazione
1	Di2 (Ingresso digitale 2)	Velocità: 100%	Velocità: 30-120%, con incrementi del 5% ;
2	Di3 (Ingresso digitale 3)	Velocità: 80%	Portata: 1 m ³ /h incrementi; DCP12-IG: 8-25 m ³ /h Nota : premere  A passare al flusso valutare collocamento .
3	Di4 (Ingresso digitale 4)	Velocità: 40%	
4	lavaggio a controcorrente	Velocità: 100%	
5	Modalità di controllo dell'ingresso analogico	0	Velocità: 60-100% , con incrementi del 5%; Portata: 1 m ³ /h incrementi; DCP12-IG: 8-25 m ³ /h Nota : premere  A passare al flusso valutare collocamento.
6	Abilita o disabilita l' autoadescamento ad ogni avvio	25	0: Controllo corrente 1: Controllo della tensione 25: abilita 0: disabilita
7	Riservato	0	Non modificabile
8	Tempo di sistema	00:00	00:00 - 23:59



9	Preimpostazione 1 della modalità skimmer	Ciclo di skimmer : 01:00 Durata dello skimmer : 00:03 Velocità dello skimmer : 100%	*Ciclo di skimmer : 1 - 24 ore, 1 ora per ogni fase ; *Durata dello skimmer: 1 - 30 min, 1 min per ogni passaggio ; *Velocità dello skimmer: 30%-100%, con incrementi del 5%; *Flusso di Skimmer : di 1 m ³ /h incrementi; DCP12-IG: 8-25 m ³ /h Nota : premere  A passare al flusso valutare collocamento.
10	di tempo del preset 1 della modalità skimmer	7:00 - 21:00	Ora di inizio: 00:00 - 24:00 Ora di fine: 00:00-24:00
11	Limite di velocità	Velocità: 100%	Velocità : 6 0%-100%, con incrementi del 5%; (100% significa nessun limite di velocità) Portata : 1 m ³ /h incrementi; DCP12-IG: 15-25 m ³ /h Nota : premere  A passare al flusso valutare collocamento .
12	RS485	170(0xAA)	160-190 (0xA0-0xBF), ogni passo di 1.
13	Riservato	0	Non modificabile

Ad esempio: come abilitare / Disattivare la funzione di autoadescamento?

- 1) Inserire l'impostazione dei parametri: Spegner la pompa, quindi tenere premuti entrambi i pulsanti

  per 3 secondi;

- 2) Selezionare l'indirizzo del parametro: premere  per selezionare l'indirizzo 6 ;

- 3) Abilitare o disabilitare la funzione di autoadescamento : Regolare premendo  o , 2 5= Abilita,
0=Disabilita .

6.FUNZIONAMENTO WIFI (ARTICOLO OPZIONALE)

① Scarica l'APP iGarden

② Registrazione account



Android



iOS

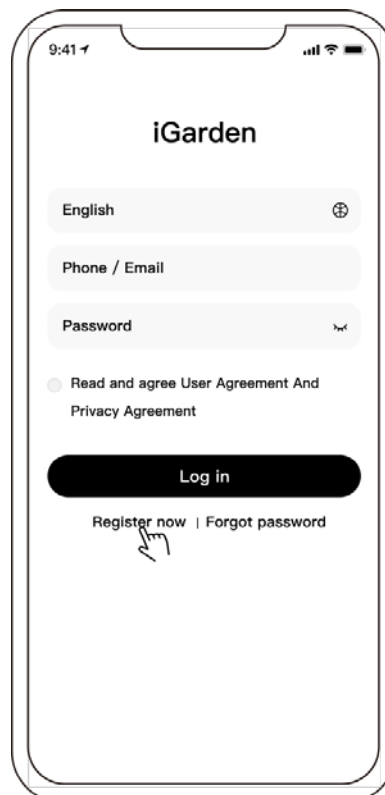

Registrazione telefonica/e-mail

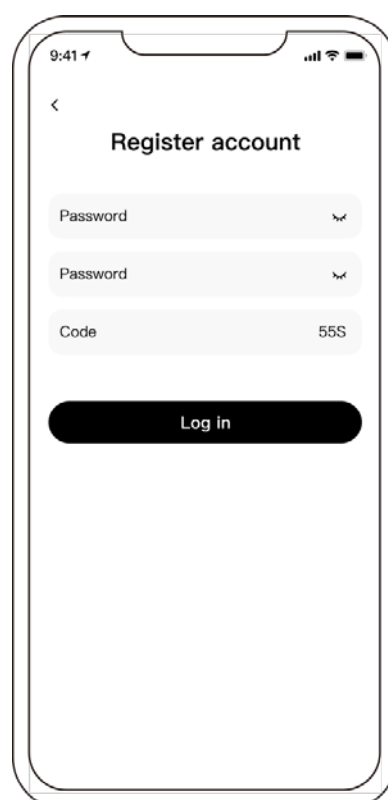



3 Abbinamento delle app

Prima di iniziare, assicurarsi che la pompa sia accesa.

(Condizioni di rete: 2,4 GHz; 2,4 GHz e 5 GHz si combinano in un unico SSID; ma nessuna rete separata a 5 GHz)

1) Verifica che il tuo telefono sia connesso al Wi-Fi e che il Bluetooth sia attivo.

2) Premere  per 3 secondi per sbloccare lo schermo. Dopo aver acceso la pompa, premere  per 5 secondi fino a sentire un "Bip", quindi rilasciare.  lampeggerà.

3) Fare clic su "Aggiungi dispositivo", quindi seguire le istruzioni per associare il dispositivo.

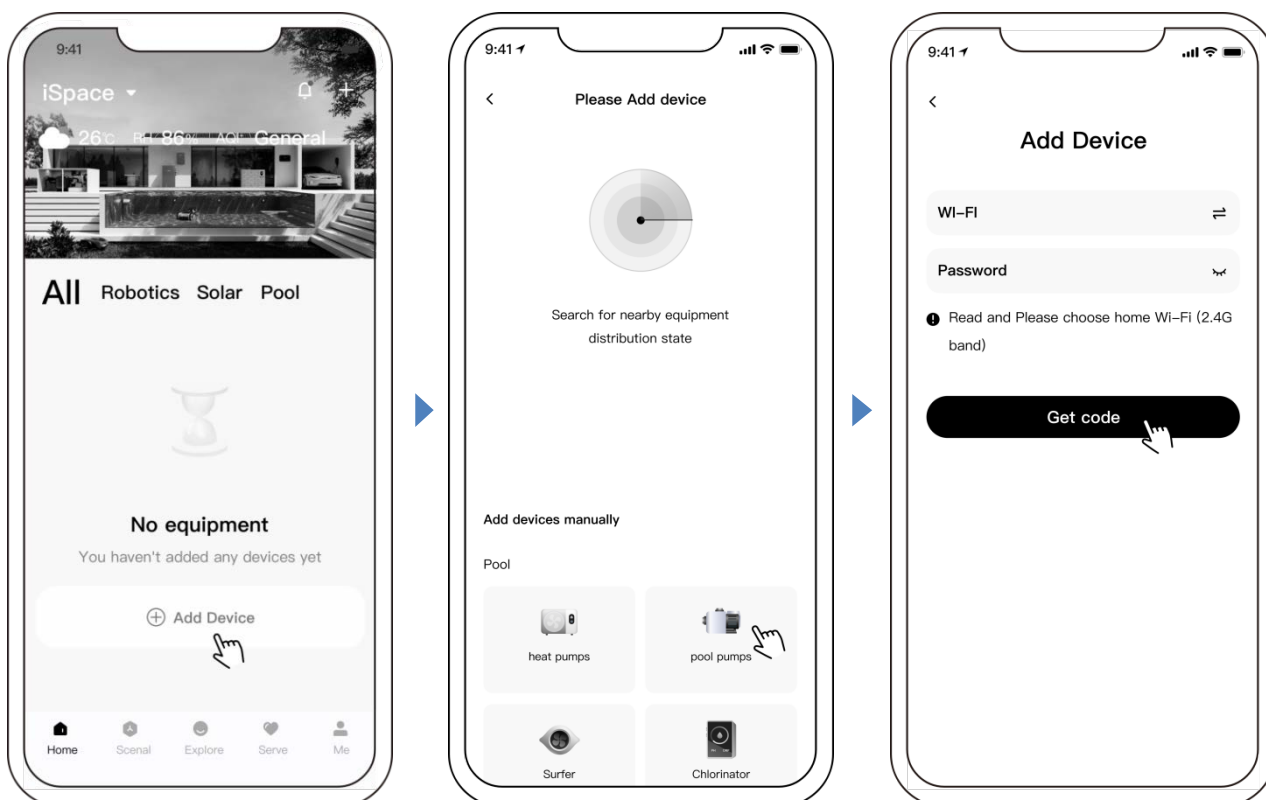

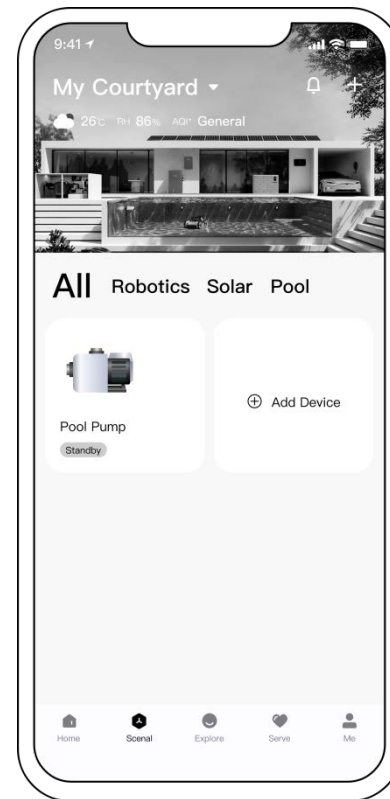
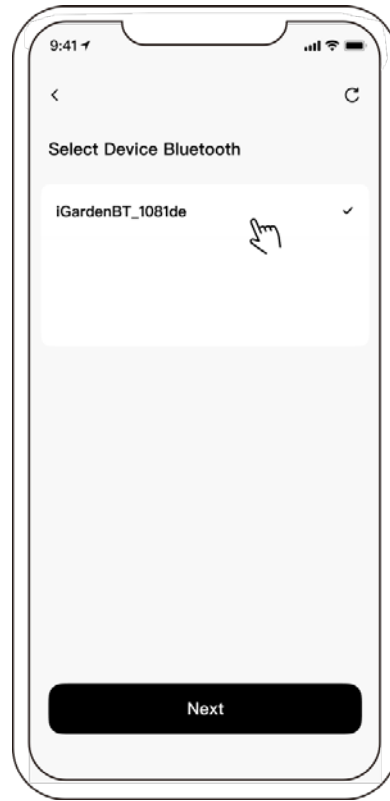
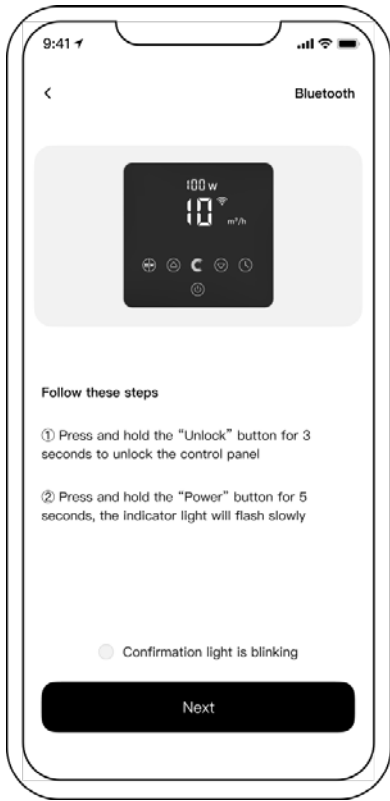

4 Operazione

1) Modalità inverter automatico (modalità AI):

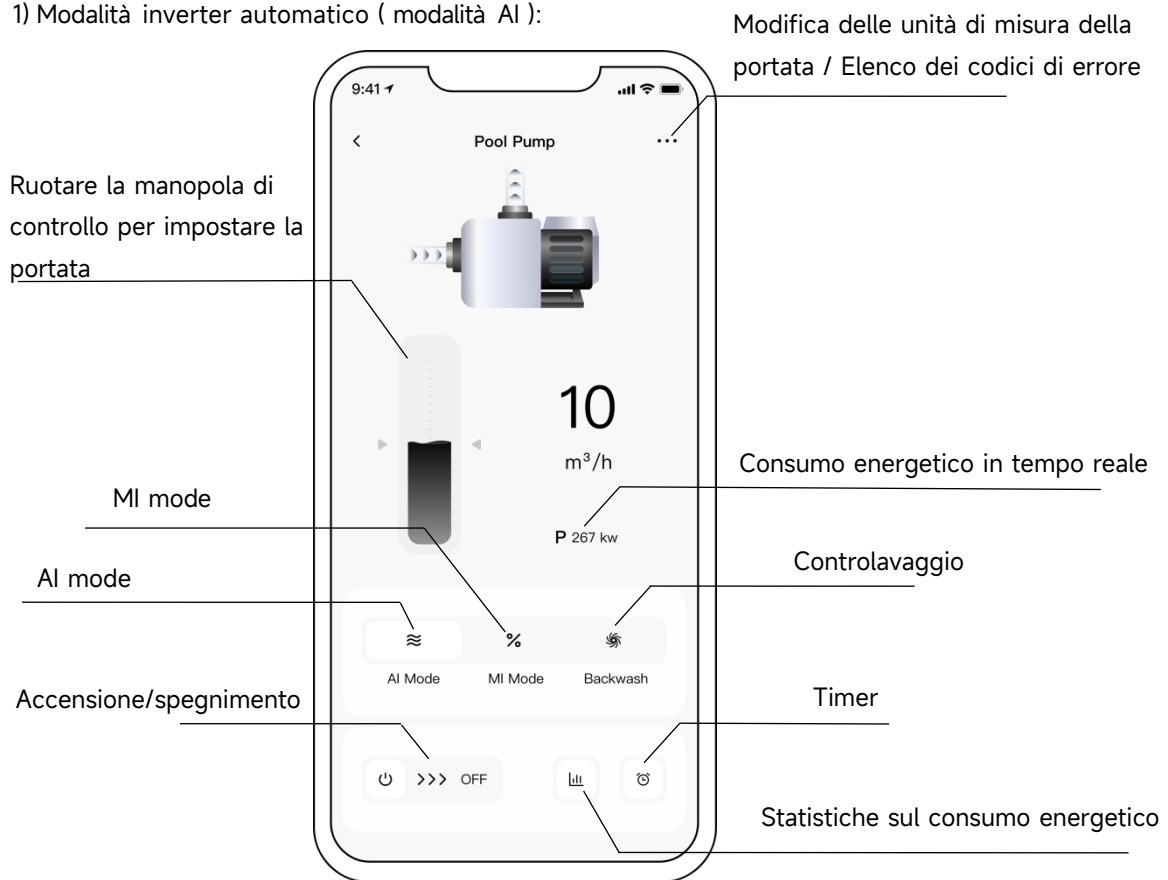

2) Modalità Inverter manuale (modalità MI):

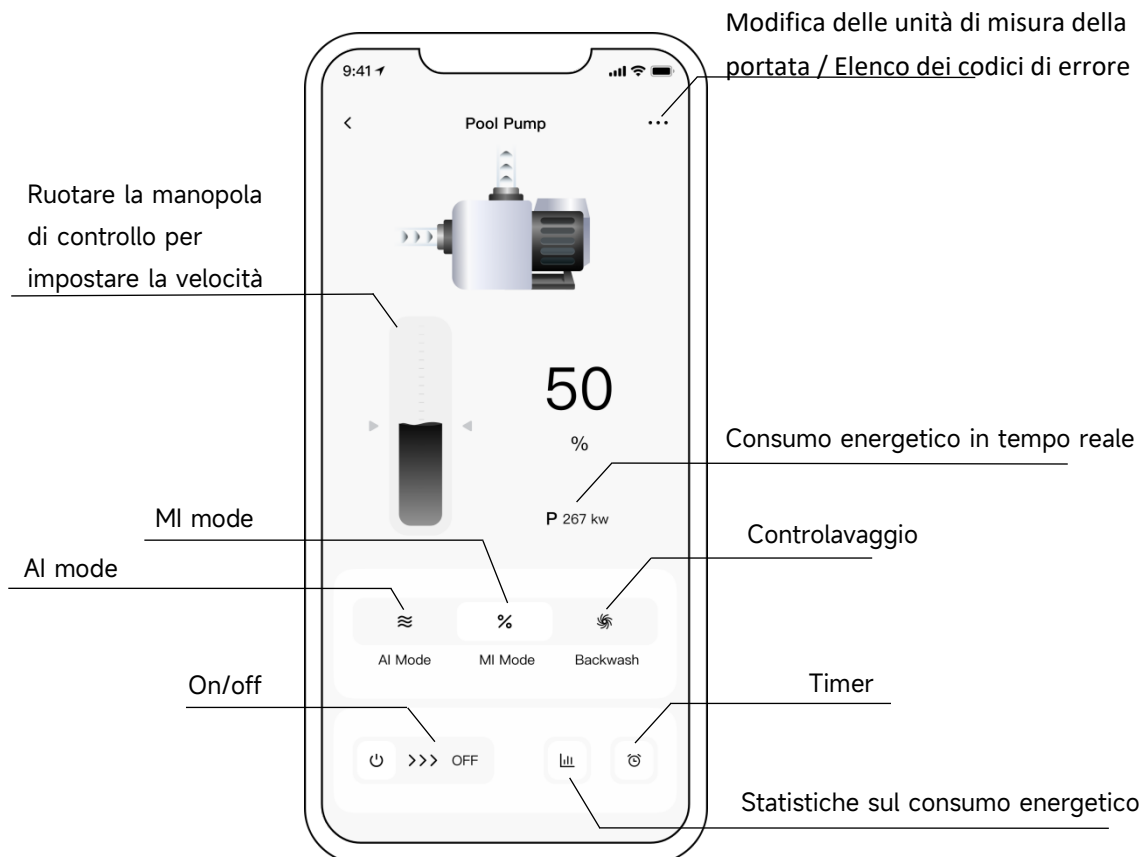

21) Modalità di controlavaggio:

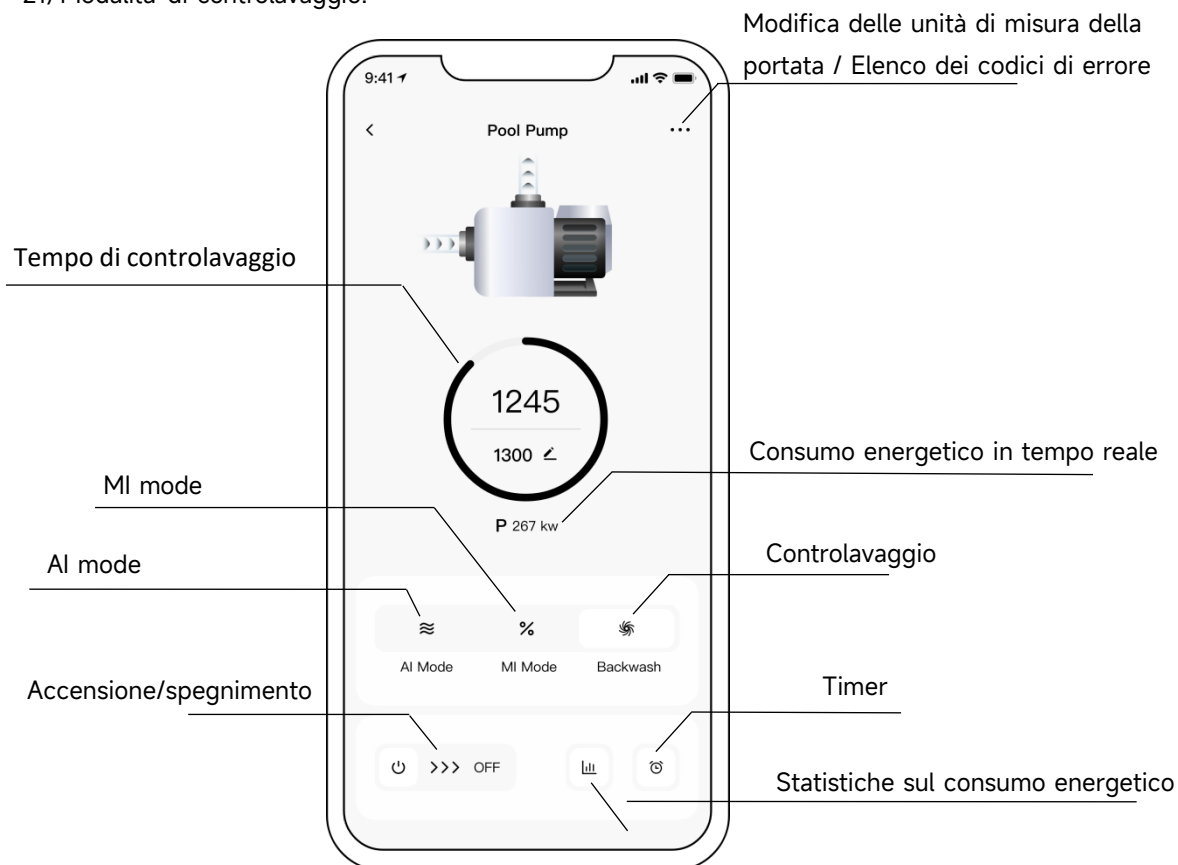

Avviso per l'impostazione del timer tramite l'APP:

- ① La variazione temporale è $\pm 30s$;
- ② Per evitare che i punti di temporizzazione sovrapposti entrino in conflitto e vengano invalidati a causa del ritardo della rete, si raccomanda che l'ora di fine e l'ora di inizio del periodo di tempo successivo non possano sovrapporsi e che venga riservato un intervallo di tempo sufficiente, ad esempio almeno 2 minuti;

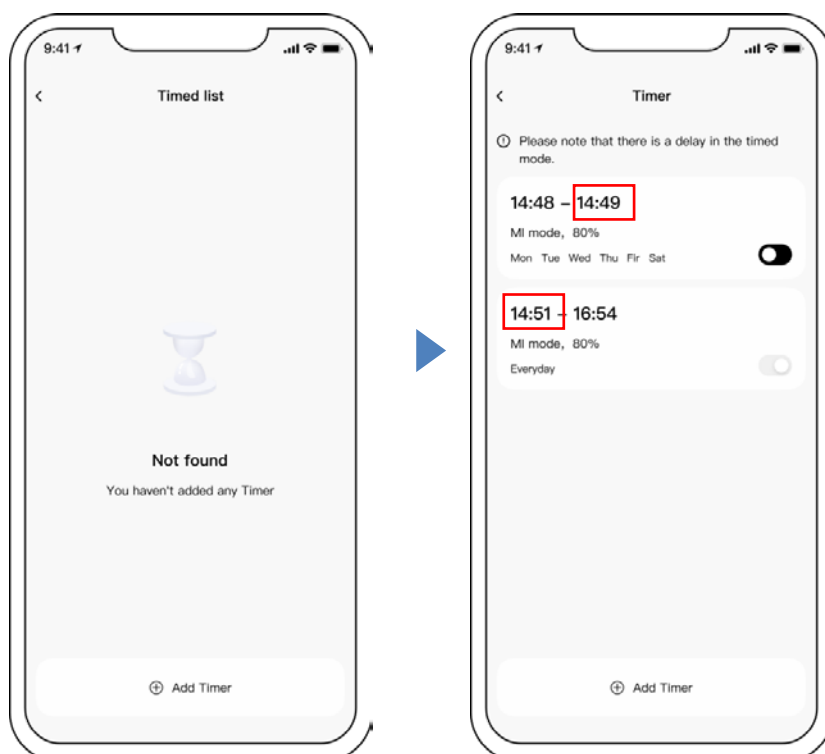

5 Condivisione dei dispositivi con i membri della tua famiglia

Gli utenti possono condividere i dispositivi affinché siano controllati dai propri familiari. Si prega di consentire ai propri familiari di registrare prima "iGarden", dopodiché l'amministratore potrà procedere come segue:

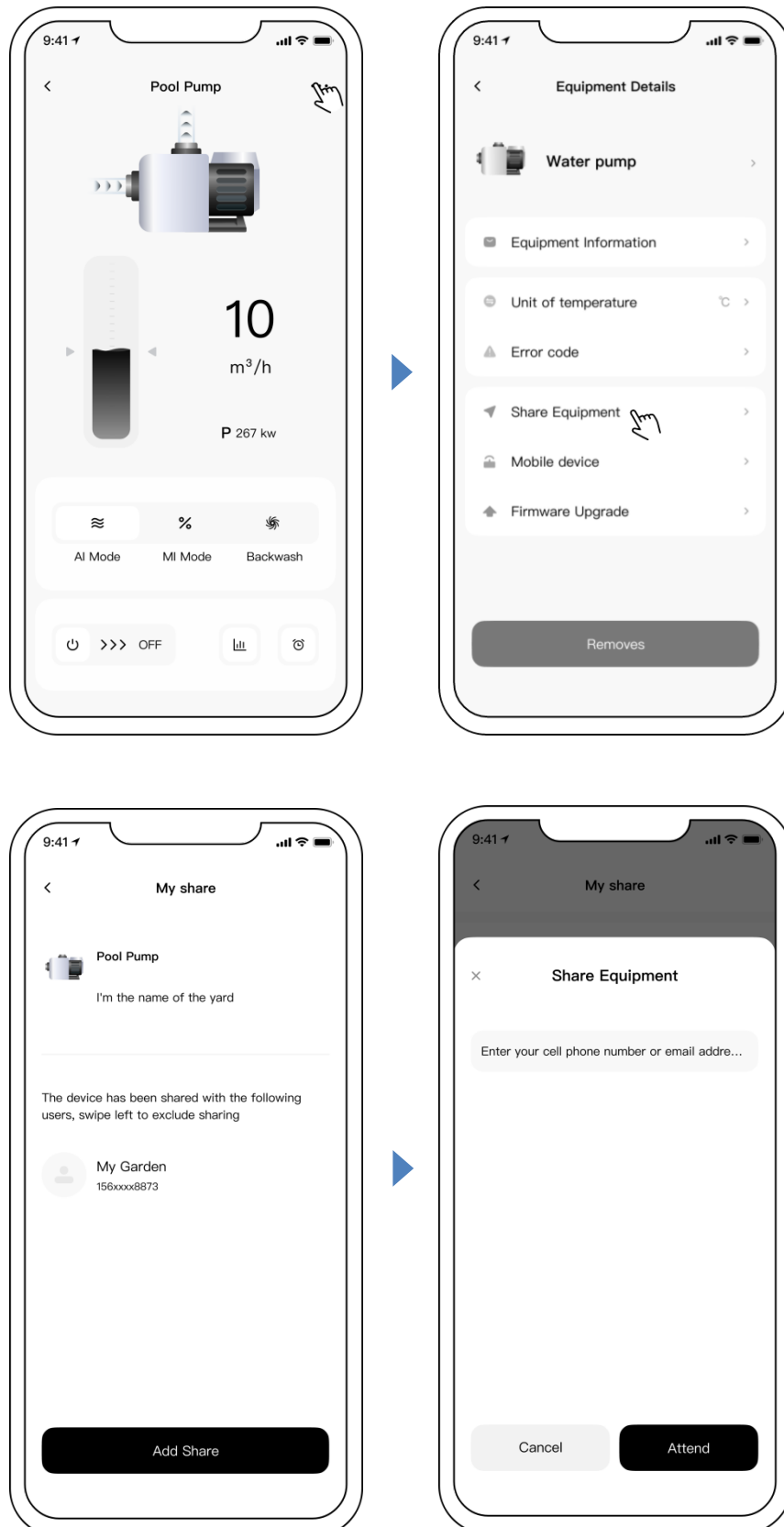

6 Gestione del giardino

Nell'elenco dei dispositivi, viene visualizzato il cortile corrente. Dopo aver cliccato, gli utenti possono visualizzare/passare a tutti i cortili correnti, cliccare su "Gestione Giardino" e accedere alla pagina dell'elenco dei cortili. Come mostrato di seguito:

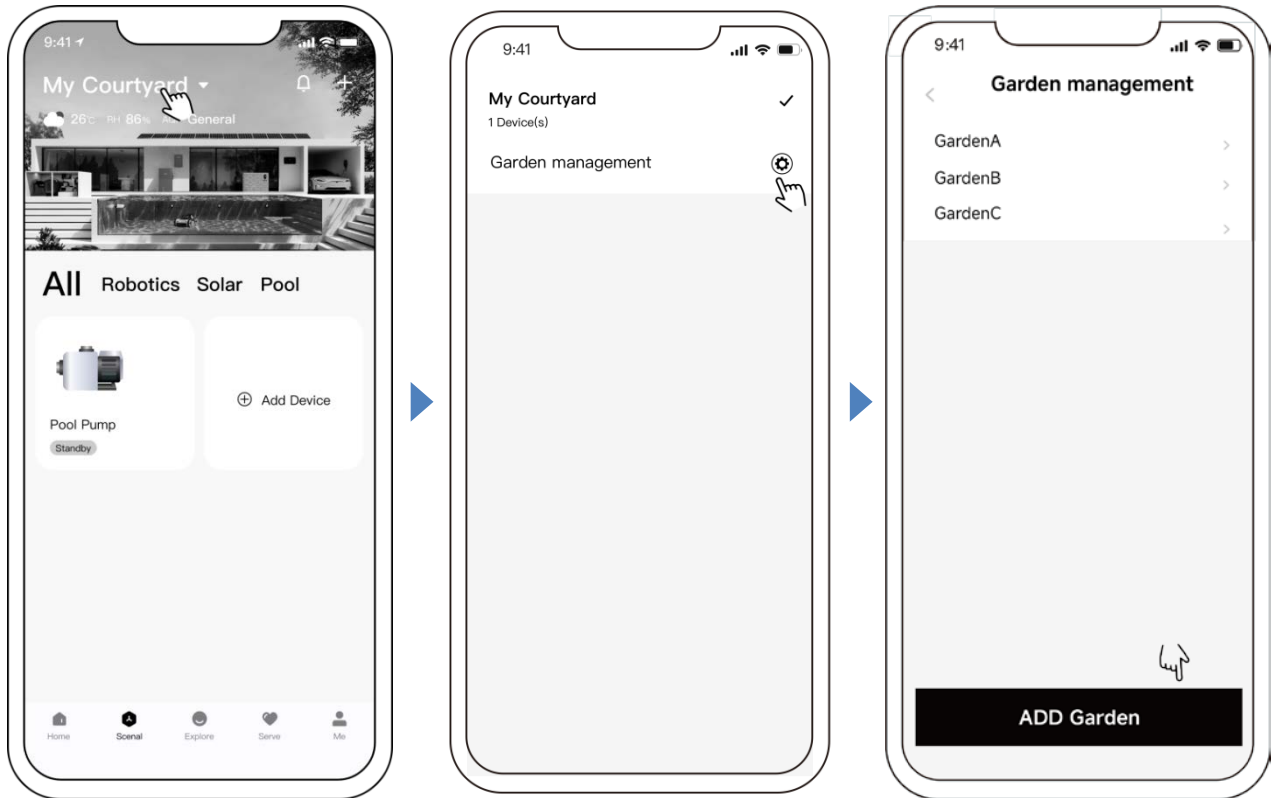

7 Centro messaggi

A: Visualizza messaggio: nella pagina dell'elenco dei dispositivi, fare clic sull'icona del messaggio per accedere al centro messaggi e visualizzare il messaggio corrispondente, come mostrato di seguito: (inclusi: Allarme, Giardino, Notifica)

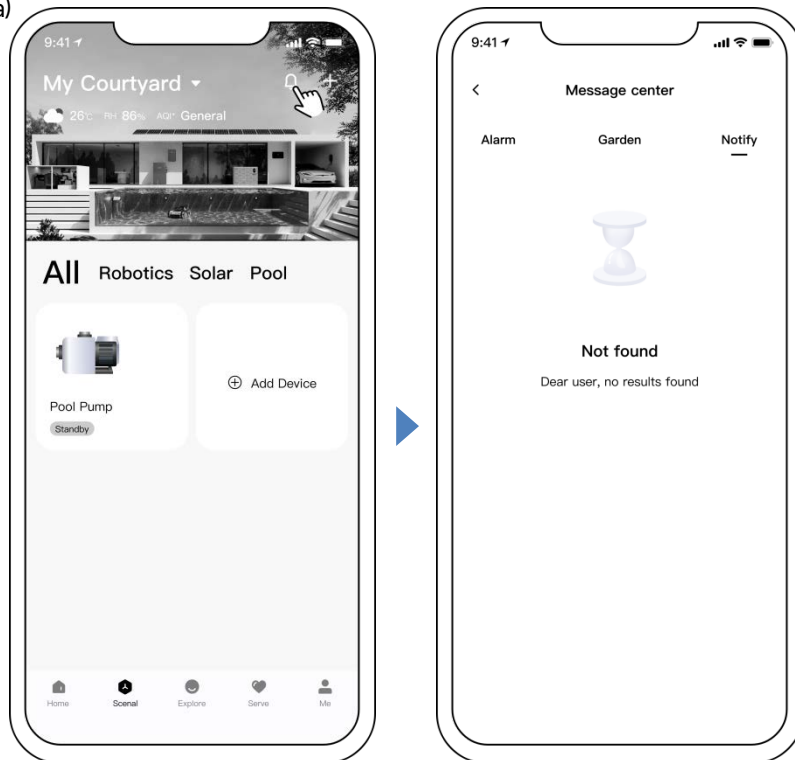

B: Impostazioni push: nella pagina Impostazioni, fare clic su [Impostazioni push] per accedere alla pagina Impostazioni push. Gli utenti possono configurare le impostazioni push in base alla classificazione dei messaggi, come mostrato di seguito:

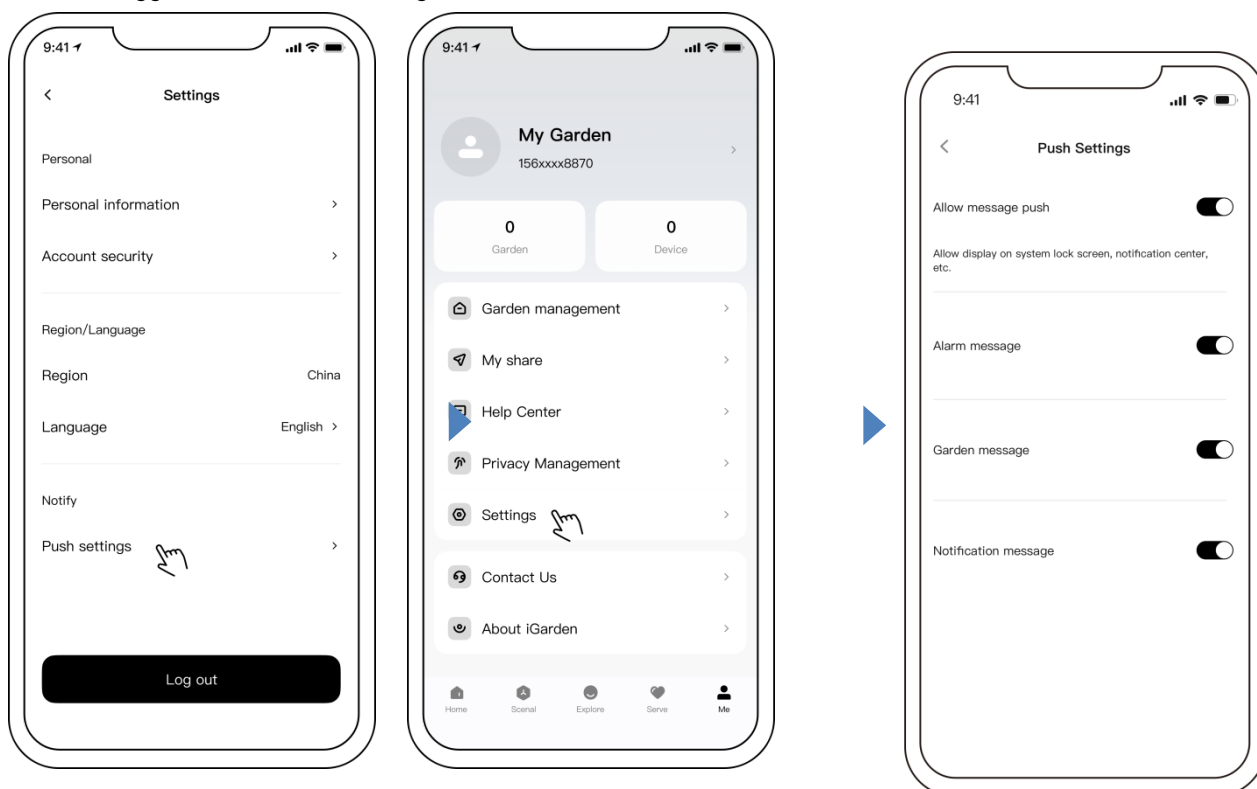

8 Feedback

Se riscontri problemi durante l'utilizzo, non esitare a inviarci un feedback. La procedura è la seguente:

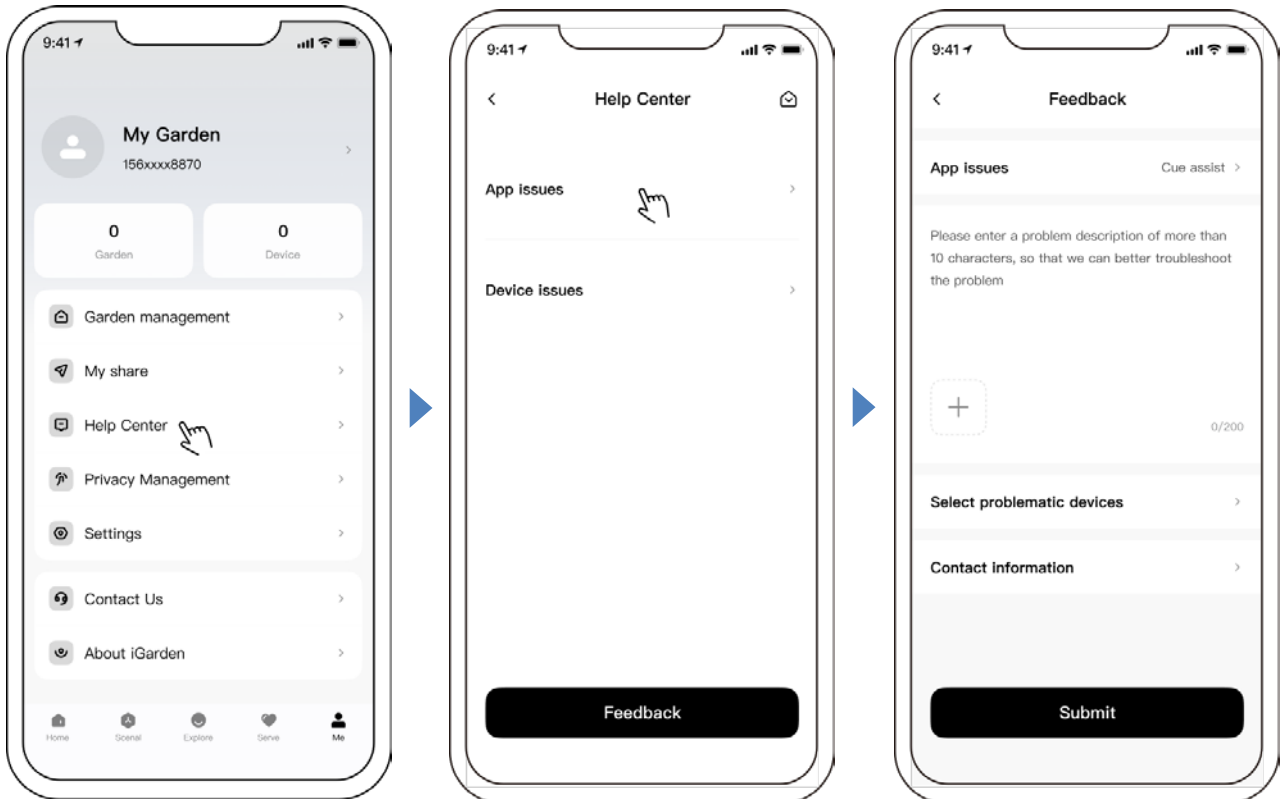

Avviso:

- 1) Le previsioni del tempo sono solo indicative;
- 2) I dati sul consumo energetico sono solo di riferimento, in quanto potrebbero essere influenzati da problemi di rete e dall'imprecisione del calcolo;
- 3) L'App è soggetta ad aggiornamenti senza preavviso.

7.CONTROLLO ESTERNO

Il controllo esterno può essere abilitato tramite i seguenti contatti. Se è abilitato più di un controllo esterno, la priorità è la seguente: Ingresso digitale > RS485 > Controllo pannello



Figura 5 - Posizione della porta del connettore



Figura 6 - Connettore per ingresso digitale e RS485

Ingresso alimentazione CA (adatto per 115 V e 230 V)

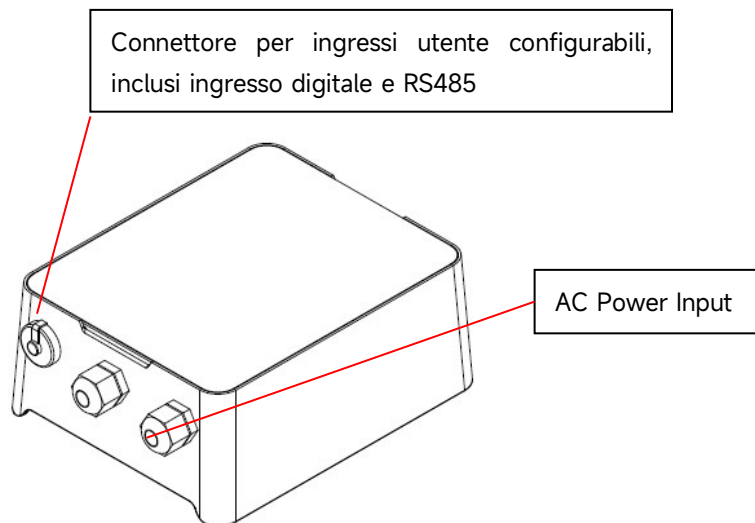

Figura 7 - Collegamento del cavo di alimentazione

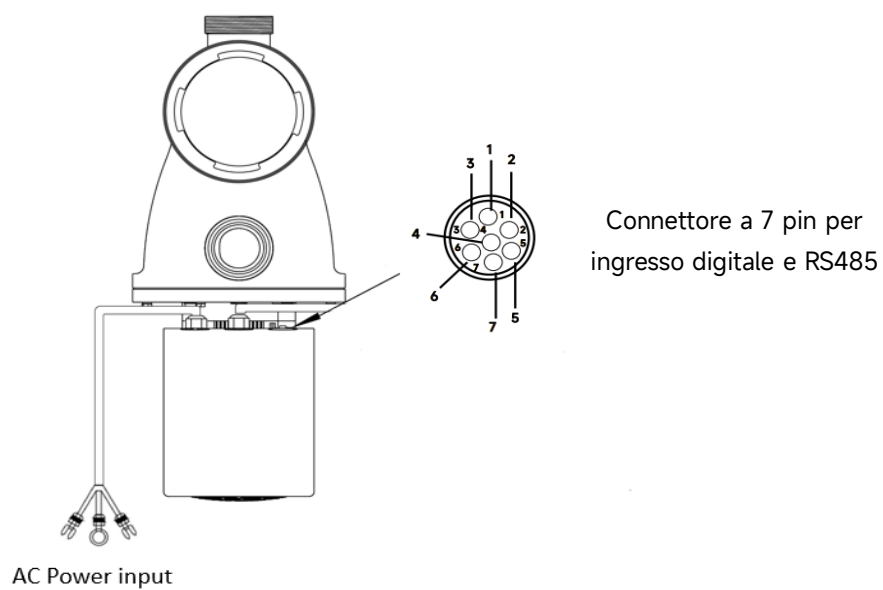
Controllo esterno	Colore	Descrizione	Nota
Ingresso digitale	Rosso	Di4 (ingresso digitale 4)	Velocità predefinita=40%
	Nero	Di3 (ingresso digitale 3)	Velocità predefinita=80%
	Bianco	Di2 (ingresso digitale 2)	Velocità predefinita=100%
	Grigio	Di1 (ingresso digitale 1)	Fermare
	Giallo	Digital Ground (COM)	COM
RS485	Verde	RS485-A	/
	Marrone	RS485-B	/

a. Ingresso digitale

La capacità di funzionamento è determinata dallo stato dell'ingresso digitale,

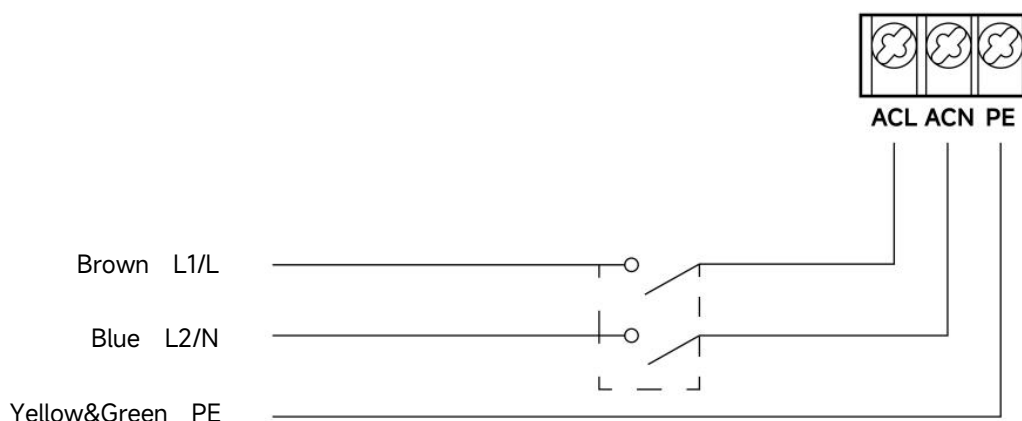
- 1) Quando Di1 (grigio) è collegato a COM (giallo), la pompa dovrà necessariamente fermarsi; se scollegato, il controllo digitale non sarà valido;
- 2) Quando Di2 (bianco) si collega a COM (giallo), la pompa dovrà obbligatoriamente funzionare al 100%; se scollegata, la priorità di controllo tornerà al controllo del pannello;
- 3) Quando Di3 (nero) si collega a COM (giallo), la pompa dovrà obbligatoriamente funzionare all'80%; se scollegata, la priorità di controllo tornerà al controllo del pannello;
- 4) Quando Di4 (rosso) si collega a COM (giallo), la pompa dovrà obbligatoriamente funzionare al 40%; se scollegata, la priorità di controllo tornerà al controllo del pannello;
- 5) La capacità degli ingressi (Di2/Di3/Di4) può essere modificata in base all'impostazione dei parametri.

b. RS485

Per connettersi con RS485-A (verde) e RS485-B (marrone), la pompa può essere controllata tramite il protocollo di comunicazione Modbus 485.

8.PROTEZIONE E GUASTO

8.1 di alta temperatura e riduzione della velocità - AL01

In "Auto Inverter/Manuale In "Modalità inverter" e "Modalità timer" (eccetto controlavaggio/autoadescamento), quando la temperatura del modulo raggiunge la soglia di attivazione dell'avviso di temperatura elevata (81°C), entra nello stato di avviso di temperatura elevata ; quando la temperatura scende alla soglia di rilascio dell'avviso di temperatura elevata (78°C), lo stato di avviso di temperatura elevata viene rilasciato. L'area di visualizzazione visualizza alternativamente AL01 e velocità di funzionamento o flusso .

Se viene visualizzato AL01, la capacità di funzionamento verrà automaticamente ridotta come segue:

- 1) Se la capacità operativa attuale è superiore al 100 %, la capacità di funzionamento verrà automaticamente ridotta all'85% ;
- 2) Se la capacità operativa attuale è compresa tra l'85% e il 100%, la capacità di funzionamento verrà automaticamente ridotta del 15%;
- 3) Se la capacità operativa attuale è compresa tra il 70% e l'85%, la capacità di funzionamento verrà automaticamente ridotta del 10%;
- 4) Se la capacità operativa attuale è inferiore al 70%, la capacità di funzionamento verrà automaticamente ridotta del 5%.

8.2 Protezione da sottotensione - AL02

Il dispositivo è compatibile sia con l'alimentazione CA a 230 V che a 115 V.

① Ingresso alimentazione CA: 230 V

Quando il dispositivo rileva che la tensione di ingresso è inferiore a 198 V, limita la velocità di funzionamento corrente. L'area di visualizzazione visualizza alternativamente AL02 e la velocità di funzionamento o la portata.

- 1) Quando la tensione di ingresso è inferiore o uguale a 180 V, la capacità di funzionamento sarà limitata al 70%;
- 2) Quando l'intervallo di tensione in ingresso è compreso tra 180 V e 190 V, la capacità di funzionamento sarà limitata al 75%;
- 3) Quando l'intervallo di tensione in ingresso è compreso tra 190 V e 198 V, la capacità di funzionamento sarà limitata all'85% .

② Ingresso alimentazione CA: 115 V

Quando il dispositivo rileva che la tensione di ingresso è inferiore a 98 V, limita la velocità di funzionamento corrente. L'area di visualizzazione visualizza alternativamente AL02 e la velocità di funzionamento o la portata.

- 1) Quando l'intervallo di tensione in ingresso è compreso tra 85 V e 90 V, la capacità di funzionamento sarà limitata al 75%;

- 2) Quando l'intervallo di tensione in ingresso è compreso tra 90 V e 98 V, la capacità di funzionamento sarà limitata all'85% .

Nota: se la tensione di ingresso è inferiore a 85 V, verrà visualizzato il codice di errore E001

(Tensione di ingresso anomala, vedere 8.4).

8.3 Risoluzione dei problemi

Problema	Possibili cause e soluzione
La pompa non si avvia	<ul style="list-style-type: none"> • Guasto all'alimentazione, cablaggio scollegato o difettoso. • Fusibili bruciati o sovraccarico termico aperto. • Verificare che la rotazione dell'albero motore si muova liberamente e non vi siano ostruzioni. • A causa di un lungo periodo di inattività, scollegare l'alimentazione e ruotare manualmente l'albero posteriore del motore alcune volte con un cacciavite.
La pompa non si adesca	<ul style="list-style-type: none"> • Svuotare l'alloggiamento della pompa/filtro. Assicurarsi che l'alloggiamento della pompa/filtro sia pieno d'acqua e che l'O-ring del coperchio sia pulito. • Collegamenti allentati sul lato di aspirazione. • Cestello del filtro o cestello dello skimmer pieno di detriti. • Lato di aspirazione intasato. • Se la distanza tra l'ingresso della pompa e il livello del liquido è superiore a 2 m, l'altezza di installazione della pompa deve essere ridotta.
Basso flusso d'acqua	<ul style="list-style-type: none"> • La pompa non si adesca. • Aria che entra nella tubazione di aspirazione. • Cestino pieno di detriti. • Livello dell'acqua inadeguato nella piscina.
La pompa è rumorosa	<ul style="list-style-type: none"> • Perdita d'aria nella tubazione di aspirazione, cavitazione causata da una linea di aspirazione ristretta o sottodimensionata o perdite in qualsiasi giunto, basso livello dell'acqua nella piscina e linee di ritorno di scarico non ristrette. • Vibrazioni causate da un'installazione non corretta, ecc. • Cuscinetto del motore o girante danneggiati (è necessario contattare il fornitore per la riparazione).

8.4 Codice di errore

Quando il dispositivo rileva un guasto, si arresta automaticamente e visualizza il codice di errore . Dopo 15 secondi di arresto , verificare se il guasto è stato risolto . Se il problema viene risolto, la pompa riprenderà a funzionare .

Articolo	Codice di errore	Dettagli	
1	E001	Descrizione	Tensione di ingresso anomala : la tensione di alimentazione è fuori dall'intervallo da 165 V a 275 V.
		Processo	La pompa si fermerà automaticamente per 15 secondi e riprenderà a funzionare se rileva che la tensione di alimentazione rientra nell'intervallo.
2	E002	Descrizione	Sovracorrente in uscita: la corrente di picco della pompa è superiore alla corrente di protezione.
		Processo	La pompa si fermerà automaticamente per 15 secondi e poi riprendere a funzionare , se ciò si verifica per tre volte consecutive, la pompa si spegnerà e dovrà essere controllata e riavviato manualmente.
3	E102	Descrizione	Radiatore Errore: la temperatura del dissipatore di calore raggiunge i 91 °C per 10 secondi . Oppure il sensore del dissipatore di calore rileva un circuito aperto o un cortocircuito .
		Processo	1. La pompa si fermerà automaticamente per 30 secondi e riprenderà a funzionare se rileva che la temperatura del dissipatore di calore è inferiore a 81 °C. 2. La pompa si fermerà automaticamente per 15 secondi e riprendere a funzionare se rileva che il sensore del dissipatore di calore non è aperto o è in cortocircuito .
4	E103	Descrizione	Errore della scheda driver principale: T he Scheda driver principale è difettoso.
		Processo	La pompa si fermerà automaticamente per 15 secondi e poi riprendere a funzionare , se ciò si verifica per tre volte consecutive, la pompa si spegnerà e dovrà essere controllata e riavviato manualmente.
5	E104	Descrizione	Protezione da mancanza di fase: i cavi del motore non sono collegati alla scheda di azionamento principale .
		Processo	La pompa si fermerà automaticamente per 15 secondi e poi riprendere a funzionare , se ciò si verifica per tre volte consecutive, la pompa si spegnerà e dovrà essere controllata e riavviato manualmente.
6	E203	Descrizione	di lettura dell'ora RTC : lettura e scrittura le informazioni dell'orologio sono errate .
		Processo	IL la pompa deve essere spento e riavviato manualmente.
7	E204	Descrizione	di lettura della EEPROM della scheda display : lettura e

			scrittura le informazioni di La EEPROM del display è errata .
		Processo	IL la pompa deve essere spento e riavviato manualmente.
8	E205	Descrizione	Errore di comunicazione : T he la comunicazione tra la scheda display e la scheda driver master è interrotta e dura 15 secondi.
		Processo	La pompa si fermerà automaticamente per 15 secondi e riprendere a funzionare se rileva che la comunicazione tra la scheda display e la scheda driver master dura 1 sec.
9	E207	Descrizione	Nessuna protezione dall'acqua : la pompa è priva di acqua.
		Processo	R icaricare manualmente la pompa, riempirla d'acqua e riavviarla. Se ciò si verifica per due volte consecutive, la pompa si spegnerà e sarà necessario controllarla manualmente.
10	E209	Descrizione	Perdita di adescamento : la pompa non può autoadescarsi a causa di motivi quali il superamento dell'intervallo di aspirazione o la complessità della tubazione.
		Processo	Controllare che la pompa o la tubazione non presentino perdite, quindi riempire la pompa con acqua e riavviarla.

9.MANUTENZIONE

Svuotare frequentemente il cestello del filtro. Il cestello deve essere ispezionato attraverso il coperchio trasparente e svuotato quando si nota un evidente cumulo di rifiuti al suo interno. Seguire le seguenti istruzioni:

- 1). Scollegare l'alimentazione.
- 2). Svitare il coperchio del cestello del filtro in senso antiorario e rimuoverlo.
- 3). Sollevare il cestello del filtro.
- 4). Svuotare il cestino dai rifiuti intrappolati e, se necessario, sciacquare via i detriti.

Nota: non sbattere il cestino di plastica su una superficie dura poiché potrebbe danneggiarsi.

- 5). Ispezionare il cestello per verificare che non presenti segni di danneggiamento e sostituirlo.
- 6). Controllare l'O-ring del coperchio per eventuali allungamenti, strappi, crepe o altri danni
- 7). Richiudere il coperchio, è sufficiente stringerlo a mano.

Nota: ispezionare e pulire periodicamente il cestello del filtro contribuirà a prolungarne la durata.

10.GARANZIA ED ESCLUSIONI

Qualora si riscontri un difetto durante il periodo di garanzia, il produttore, a sua discrezione, riparerà o sostituirà tale articolo o componente a proprie spese. I clienti sono tenuti a seguire la procedura di richiesta di garanzia per poter beneficiare di questa garanzia.

La garanzia decade in caso di installazione non corretta, funzionamento improprio, uso improprio, manomissione o utilizzo di ricambi non originali.

11.DISPOSIZIONE



Quando si smaltisce il prodotto, separare i rifiuti come rifiuti elettrici o elettronici oppure consegnarli al sistema di raccolta locale dei rifiuti.

La raccolta differenziata e il riciclaggio delle apparecchiature dismesse al momento dello smaltimento contribuiranno a garantire che vengano riciclate in modo da tutelare la salute

umana e l'ambiente. Contatta l'autorità locale per informazioni su dove puoi portare la tua pompa dell'acqua per il riciclaggio.

SADRŽAJ

1. ⚠ VAŽNE SIGURNOSNE UPUTE	218
2. TEHNIČKE SPECIFIKACIJE	219
3. UKUPNE DIMENZIJE (mm)	219
4. UGRADNJA	220
5. POSTAVLJANJE I RAD	222
6. RAD WIFI-JA (IZBORNA STAVKA)	231
7. VANJSKA KONTROLA	240
8. ZAŠTITA I KVAR	242
9. ODRŽAVANJE	30
10. JAMSTVO I IZUZETKE	30
11. ZBRINJAVANJE	30

HVALA VAM NA KUPNJI NAŠIH INVERTERSKIH PUMPI ZA BAZEN.

OVO UPUTSTVO SADRŽI VAŽNE INFORMACIJE KOJE ĆE VAM POMOĆI U RUKOVANJU I ODRŽAVANJU OVOG PROIZVODA.

MOLIMO VAS DA PAŽLJIVO PROČITATE UPUTSTVO PRIJE INSTALACIJE I UPOTREBE I DA GA SAČUVATE ZA BUDUĆU UPOTREBU.

1. VAŽNE SIGURNOSNE UPUTE

Prilikom postavljanja i korištenja ove električne opreme uvijek treba slijediti osnovne sigurnosne mjere, uključujući sljedeće:

- 1) PROČITAJTE I SLIJEDITE SVE UPUTE
- 2) UPOZORENJE – Kako biste smanjili rizik od ozljeda, nemojte dopustiti djeci da koriste ovaj proizvod osim ako nisu pod stalnim strogim nadzorom.
- 3) UPOZORENJE – Opasnost od strujnog udara. Spajajte samo na ogranak strujnog kruga zaštićen uređajem za zaštitu od struje (RCD) s nazivnom preostalom radnom strujom koja ne prelazi 30 mA. Obratite se kvalificiranom električaru ako ne možete provjeriti je li strujni krug zaštićen uređajem za zaštitu od struje.
- 4) KAKO BISTE SPRIJEČILI OPASNOST OD STRUJNOG UDARA, spojite žicu za uzemljenje na motoru (zeleno/žuta) na sustav uzemljenja..
- 5) UPOZORENJE – Kako biste smanjili rizik od strujnog udara, odmah zamijenite oštećeni kabel.
- 6) Ne postavljajte unutar vanjskog ograđenog prostora ili ispod ruba hidromasažne kade ili spa centra.
- 7) Rastavljač mora biti ugrađen na fiksnu električnu instalaciju u skladu s propisima o instalaciji.
- 8) Za upotrebu s bazenima, hidromasažnim kadama i spa centrima.
- 9) OPREZ: Kako biste smanjili rizik od strujnog udara, postavite najmanje 1.8 metra od unutarnjih stijenki bazena. Ne koristite produžni kabel.
- 10) OPREZ: Kako biste osigurali trajnu zaštitu od strujnog udara, prilikom servisiranja koristite samo identične rezervne dijelove .
- 11) Ova pumpa je namijenjena za korištenje s trajno ugrađenim bazenima, ukopanim ili nadzemnim, a može se koristiti i s hidromasažnim kadama i spa centrima s temperaturom vode ispod 50°C . Zbog fiksne metode instalacije, ne preporučuje se korištenje ove pumpe na nadzemnim bazenima koji se mogu lako rastaviti radi skladištenja.
- 12) Pumpa nije potopljiva.
- 13) Nikada ne otvarajte unutrašnjost kućišta pogonskog motora.
- 14) SAČUVAJTE OVE UPUTE.

UPOZORENJE:

- Prije pokretanja napunite pumpu vodom. Ne dopustite da pumpa radi na suho. U slučaju rada na suho, mehanička brtva će se oštetiti i pumpa će početi propuštati.
- Prije servisiranja pumpe, ISKLJUČITE napajanje pumpe odspajanjem glavnog strujnog kruga pumpe i ispustite sav tlak iz pumpe i cjevovodnog sustava.
- Nikada ne zatežite ili otpuštajte vijke dok pumpa radi.
- Provjerite jesu li ulaz i izlaz pumpe začepljeni stranim tvarima.

2.TEHNIČKE SPECIFIKACIJE

Model	Preporučeni volumen bazena (m ³)	P1	Napon (V/Hz)	Qmax (m ³ /h)	Hmax (m)	Cirkulacija (m ³ /h)	
		kW				Na 10 m	Na 8 m
DCP12-IG	40-70	1.2	220-240/ 50/60	28,0	21,0	23,0	26,0

3.UKUPNE DIMENZIJE (mm)

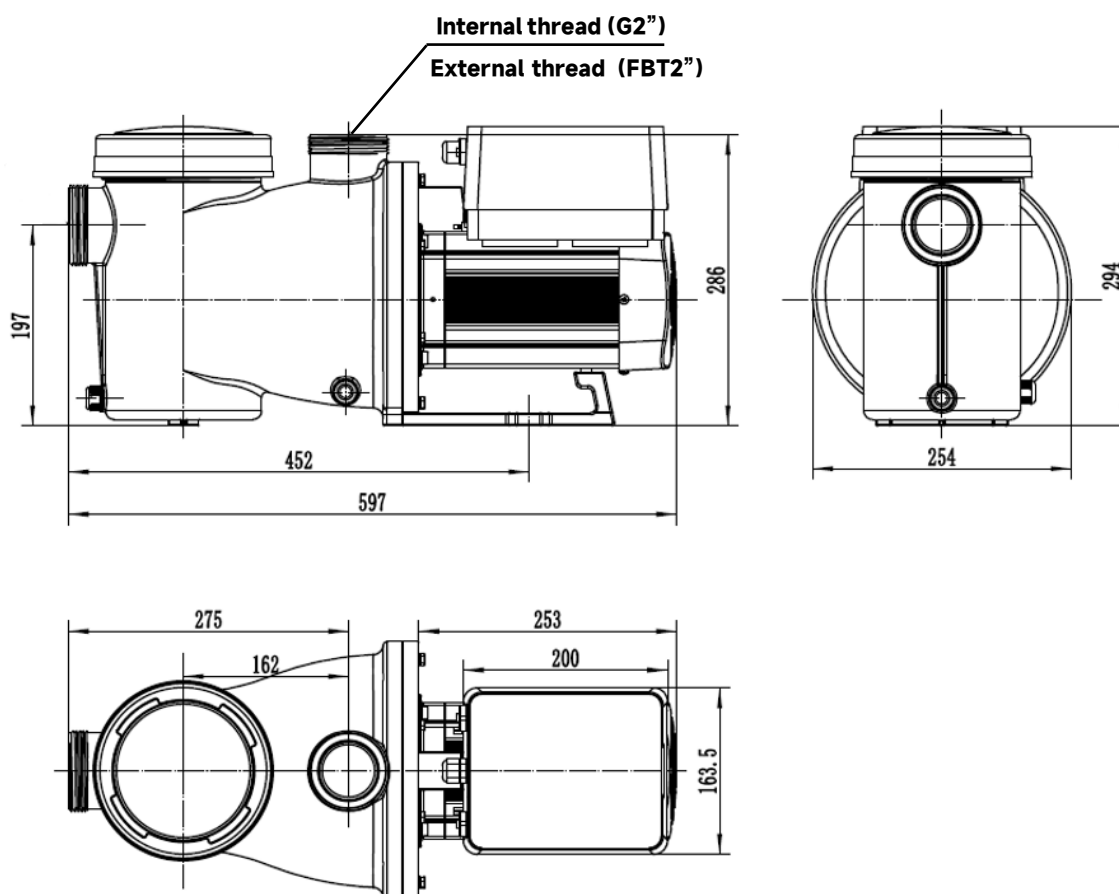

Slika 1 - Dimenzije pumpe

4.MONTAŽA

4.1 Lokacija pumpe

- 1) Instalirajte pumpu što bliže bazenu, kako biste smanjili gubitak trenja i poboljšali učinkovitost, koristite kratke, izravne usisne i povratne cijevi.
- 2) Kako biste izbjegli izravnu sunčevu svjetlost, vrućinu ili kišu, preporučuje se postavljanje pumpe u zatvorenom prostoru ili u sjenu.
- 3) NE postavljajte pumpu na vlažno ili neprozračeno mjesto. Držite pumpu i motor najmanje 150 mm od prepreka, motori pumpe zahtijevaju slobodnu cirkulaciju zraka za hlađenje.
- 4) Pumpa treba biti postavljena vodoravno i pričvršćena u rupu na nosaču vijcima kako bi se spriječila nepotrebna buka i vibracije.

4.2 Vodovod i ventili

- 1) Veličina ulaznog/izlaznog spoja pumpe: opcionalno s metričkim (50 ili 63 mm) ili imperijalnim (1,5 " ili 2").
- 2) Za optimizaciju vodovoda bazena, treba koristiti cijev većeg promjera. Preporučuje se korištenje cijevi veličine 63mm.
- 3) Prilikom postavljanja ulaznih i izlaznih spojeva s vodovodom, koristite posebno brtvilo za PVC materijal.
- 4) Dimenzija usisne cijevi treba biti ista ili veća od promjera ulazne cijevi kako bi se izbjeglo usisavanje zraka pumpom, što bi utjecalo na učinkovitost pumpe.
- 5) Kako bi se smanjio gubitak trenja i poboljšala učinkovitost, vodovodne cijevi na usisnoj i povratnoj strani trebaju biti kratke i izravne.
- 6) Poplavljeni usisni sustavi trebaju imati ventile ugrađene i u usisnom i u povratnom vodu pumpe, što je praktično za rutinsko održavanje. Ventil, koljeno ili T-komad ugrađen na usisni vod ne smije biti bliže prednjem dijelu pumpe od sedam puta većeg promjera usisnog voda.
- 7) Koristite nepovratni ventil u povratnom vodu tamo gdje postoji značajna visina između povratnog voda i izlaza pumpe kako biste spriječili utjecaj recirkulacije medija i vodenog udara koji može zaustaviti pumpu .

4.3 Priklučci

~ Koljena ne smiju biti bliže od 350 mm od ulaza. Ne postavljajte koljena od 90° izravno u ulaz/izlaz pumpe.

~ Spojevi moraju biti čvrsti.

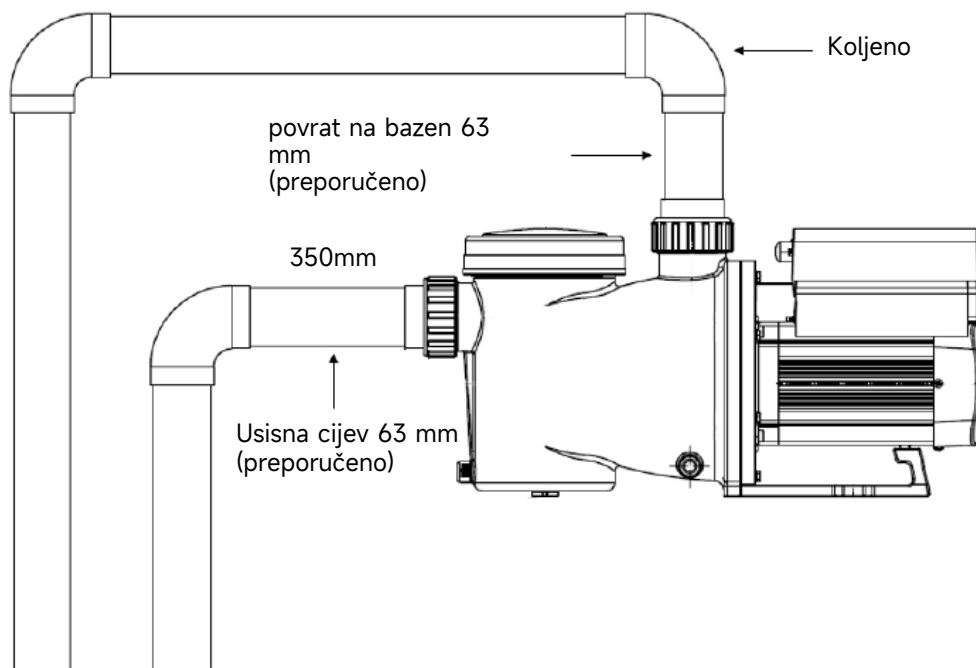
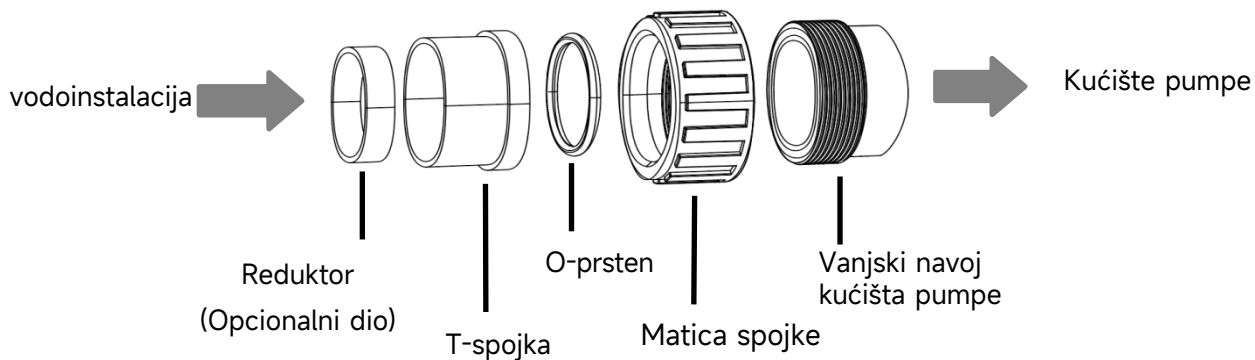

Figure 2 - Plumbing and Fittings installations

* Veličina ulaznog/izlaznog spoja pumpe: opcionalno s metričkim (50 ili 63 mm) ili imperijalnim (1,5 " ili 2")

~ Koristite KOMPLET ZA SPOJENJE koji isporučuje proizvođač pumpe (pogledajte sliku 3). Ne koristite druge spojnice za spajanje ulaza/izlaza pumpe, u slučaju da se spojnice ne podudaraju i oštete tijelo pumpe.



Slika 3 - Union Kit

4.4 Provjerite prije prvog puštanja u rad

- 1) Provjerite okreće li se osovina pumpe slobodno;
- 2) Provjerite odgovaraju li napon i frekvencija napajanja natpisnoj pločici;
- 3) Okrenut prema lopaticama ventilatora, smjer vrtnje motora trebao bi biti u smjeru kazaljke na satu;
- 4) Zabranjeno je pokretati pumpu bez vode.

4.5 Uvjeti primjene

Temperatura okoline	Unutarnja ugradnja, temperaturni raspon: -10-42°C
Maksimalna temperatura vode	50°C
Dostupna slana voda	Koncentracija soli do 3,5%, tj. 35 g/l
Vlažnost	≤90% relativne vlažnosti, (20°C±2°C)
Montaža	Pumpa se može instalirati maksimalno 2 m iznad razine vode
Zaštita	Klasa F, IP55

5.POSTAVLJANJE I RAD



5.1 Prikaz na upravljačkoj ploči

	1.Potrošnja energije
	2.Radni kapacitet / Protok
	3. WIFI indikator (dodatna stavka)
	4.Jedinica protoka
	5.Razdoblje timera
	6.Tajmer 1/2/3/4
	Ispiranje/otključavanje
	Gore/dolje: za promjenu vrijednosti postavke
	Prebacivanje između ručnog Inverterski način rada i Auto Inverterski način rada. Priručnik Inverterski način rada : Radni kapacitet će se ručno podesiti između 30% i 120 %. Auto Inverterski način rada : Radni kapacitet će se automatski podešavati između 30% i 120 % prema unaprijed postavljenom protoku. Zadani način rada je Priručnik Inverter način rada.
	Postavljanje timera
Uključeno/isključeno	

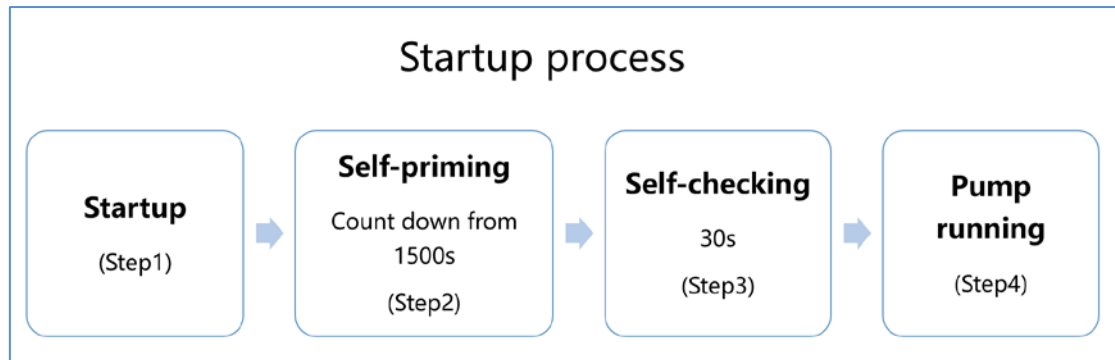
5.2 Pokretanje proces pregled



1) Korak 1 : Pokretanje

- Pritisnite i držite  dulje od 3 sekunde za otključavanje zaslona .
- Pritisnite  do pokretanje the pumpa.

2) Korak 2 : Samoučvršćivanje

- On pumpa početak će odbrojanje od 1500 s ; Kada sustav otkrije da je pumpa puna vode, zaustavit će odbrojanje i automatski će izaći iz punjenja .
- Korisnici mogu unijeti postavke parametara kako bi onemogućili zadanu funkciju samousisavanja (vidi 5.11) .



3) Korak 3 : Samoprovjera

- On pumpa ponovno će provjeriti 30 sekundi kako bi se uvjerio da je samousisavanje (korak 2) završeno .

4) Korak 4 : Pumpa trčanje

- Pumpa će raditi s 80% radnog kapaciteta pri početnom pokretanju nakon samousisavanja.

5.3 Pokretanje

Kada se napajanje uključi, zaslon će potpuno zasvijetli 3 sekunde , prikazat će se kod uređaja, a zatim će ući u normalno radno stanje. Kada je zaslon zaključan, prikazuje se samo gumb  će zasvijetliti; Pritisnite i držite  dulje od 3 sekunde za otključavanje zaslona . Zaslon će se automatski zaključati kada se ne koristi dulje od 1 minute, a svjetlina zaslona smanjit će se na 1/3 normalnog prikaza. Kratko pritisnite  za buđenje zaslona i promatranje relevantnih radnih parametara.

5.4 Samousisavanje

Svaki put kada se pumpa pokrene , ona će započeti samousisavanje .

Kada pumpa radi samousisavanje, odbrojavanje će početi od 1500 sekundi i automatski zaustavlja odbrojavanje kada sustav otkrije da je pumpa puna vode, a zatim će sustav ponovno provjeravati 30 sekundi kako bi se uvjerio da je samousisavanje završeno .



Korisnici mogu ručno otkazati samousisavanje pritiskom na  dulje od 3 sekunde . Pumpa će prilikom prvog pokretanja ući u zadani ručni inverterski način rada.

Napomena:

Pumpa se isporučuje s omogućenim samousisavanjem. Svaki put kada se pumpa ponovno pokrene, automatski će se izvršiti samousisavanje. Korisnici mogu unijeti postavke parametara kako bi onemogućili zadanu funkciju samousisavanja (vidi 5.11) .

5.5 Talasanje











Korisnici mogu pokrenuti ispiranje ili brzu recirkulaciju u bilo kojem stanju rada pritiskom  na .

	Zadano	Raspon podešavanja
Vrijeme	180-ih	Pritisnite  ili  za podešavanje od 0 do 1500 s , u koracima od 30 s u koracima od 30 s
Kapacitet trčanja	100%	60-100%, unesite postavku parametra (vidi 5. 11)

Izlaz za ispiranje:

Kada je način rada povratnog ispiranja uključen, korisnici ga mogu otkazati  pritiskom na 3 sekunde , pumpa će se vratiti u prethodno stanje prije povratnog ispiranja. Ako korisnici postave ograničenje brzine, radni kapacitet povratnog ispiranja neće premašiti postavljeno ograničenje brzine. (vidi 5. 10)

5.6 Priručnik Inverterski način rada













1		Držite  dulje od 3 sekunde za otključavanje zaslona .
2		Pritisnite  za pokretanje. Pumpa će raditi s 80% radnog kapaciteta pri početnom pokretanju nakon samousisavanja.
3	 	Pritisnite  ili  za postavljanje radnog kapaciteta između 30% i 120%, u koracima od 5% .
4		pritisnite  za prelazak u automatski inverterski način rada.

Napomena :

- 1) Kada je tlak u cjevovodu visok, korisnik može postaviti radni kapacitet na 105%-120% kako bi održao odgovarajući protok . Crpka će raditi većom brzinom kako bi se suprotstavila visokom tlaku u cjevovodu.
- 2) U rasponu od 105%~120% radnog kapaciteta, pumpa će automatski prilagoditi brzinu kada dostigne maksimalnu snagu.
- 3) Na primjer, kada korisnik podesi brzinu na 110 % , ako pumpa Snaga je dosegla maksimalnu vrijednost pri ovoj brzini . U ovom trenutku, čak i ako korisnik nastavi povećavati brzinu pumpe na 120% , pumpa će održavati brzinu na maksimalnoj snazi, tj. 110 % . Prikazana brzina će pasti sa 120% na 110%.

5.7 Auto Inverterski način rada

U automatskom inverterskom načinu rada, pumpa može automatski detektirati tlak u sustavu i prilagoditi brzinu motora kako bi se postigao zadani protok.

1		Otključajte zaslon, pritisnite  za prelazak iz ručnog načina rada invertera u automatski način rada invertera.
2	 	Brzina protoka može se podesiti pritiskom na  ili  s 1 m ³ /h za svaki korak.
3	 	Jedinica protoka može se promijeniti u L /min , IMP gpm ili US gpm pritiskom na oba   na 3 sekunde .
4		Pritisnite  za prelazak na ručni inverterski način rada .

Zadani podesivi raspon protoka za InverK je sljedeći :

Model	Podesivi raspon protoka *
DCP12-IG	8-25 m ³ /h

*** Napomena :**











U automatskom inverterskom načinu rada, maksimalni podesivi protok temelji se na visini od oko 8 m.

Ako korisnici postave protok na maksimalnu podesivu brzinu protoka, a tlak u cjevovodu je veći od 8 m, u toj situaciji pumpa će automatski povećati brzinu rada i ulaznu snagu kako bi se suprotstavila visokom tlaku i održavala maksimalnu brzinu protoka koju su korisnici postavili.

Kada se brzina motora i ulazna snaga povećaju do maksimalne razine, ali to nije dovoljno za suočavanje s ogromnim tlakom u cjevovodu, prikazani protok na regulatoru pumpe pasti će s postavljenog protoka na stvarno ostvarivi protok .

5.8 Način rada timera

Uključivanje/isključivanje i radni kapacitet pumpe mogu se kontrolirati pomoću tajmer, koji se može programirati svakodnevno prema potrebi.

1	Uđite u postavke timera pritiskom na 
2	Pritisnite  ili  za postavljanje lokalnog vremena
3	Pritisnite  za potvrdu i prelazak na postavku vremena 1
4	Pritisnite  ili  odabrati željena razdoblja rada , kapacitet rada ili brzinu protoka (kada ikona % treperi, korisnici mogu promijeniti postavku protoka pritiskom na 
5	 Ponovite gore navedene korake za postavljanje ostala 3 timera
6	 Držite 3 sekunde za spremanje postavki i aktiviranje načina rada timera
7	 ili  provjerite 4 timera kako biste bili sigurni da nema nevažećih postavki

Bilješka:

- 1 Ako postavljeno vremensko razdoblje sadrži trenutno vrijeme, pumpa će početi raditi prema postavljenom radnom kapacitetu ili protoku , a trenutni indikator timera 1 2 3 4 (1 ili 2 ili 3 ili 4) će se upaliti, a područje **88:88 - 88:88** prikazat će odgovarajuće vremensko razdoblje .
- 2 Ako postavljeno vremensko razdoblje ne sadrži trenutno vrijeme, broj timera 1 2 3 4 (1 ili 2 ili 3 ili 4) koji će se uskoro pokrenuti bit će prikazan i treptat će , a područje **88:88 - 88:88**

prikazat će odgovarajuće vremensko razdoblje .

3 Tijekom podešavanja timera, ako se želite vratiti na prethodnu postavku, držite oba



sekunde. Ako ne trebate postaviti sva 4 timera, možete držati  3 sekunde, sustav će automatski spremi trenutno postavljenu vrijednost i aktivirati način rada timera.



4 Postavke timera pumpe su ograničene , korisnici neće postavljati preklapajuće timere .



5 Nakon što je timer postavljen i korisnici isključe pumpu, kada ponovno uključe pumpu, ona će se vratiti u način rada timera.

11 Korisnici mogu otkazati način rada timera pritiskom na .

5.9 Skimmer Način rada

skimera omogućuje pumpi da obriče površinu vode, sprječava nakupljanje nečistoća i korisnicima osigurava čišći bazen.

Držite pritisnute tipke  i  za ulazak u sučelje unaprijed postavljenih postavki načina rada skimera. Prilikom prvog prebacivanja na ovaj način rada, aktivirat će se unaprijed postavljena postavka 1.

Korisnici mogu pritisnuti  ili  za pregled 4 unaprijed postavljenih postavki, detalji svake unaprijed postavljene postavke navedeni su u nastavku, odabrana unaprijed postavljena postavka aktivirat će se nakon 5 sekundi bez rada.

Presetiranje	Skimmer ciklus	Trajanje Skimera	Brzina Skimera	Vremensko razdoblje	Napomena
1	1 sat	3 minute	100%	7:00 – 21:00	Može se uređivati u podešavanje parametara
2	1 sat	10 min	100%	7:00 – 21:00	Nije moguće uređivati
3	3 sata	3 minute	80%	7:00 – 21:00	Nije moguće uređivati
4	Isključite način rada skimera				Nije moguće uređivati

Tablica 1 - Presetne postavke načina rada skimera

Tijekom trajanja skimera, kontroler će prikazati parametar unaprijed postavljene postavke, korisnik može zadržati  3 sekunde kako biste svaki put otkazali trajanje skimera. Kada trajanje skimera završi, pumpa će se vratiti u normalno stanje kako bi korisnik mogao raditi.

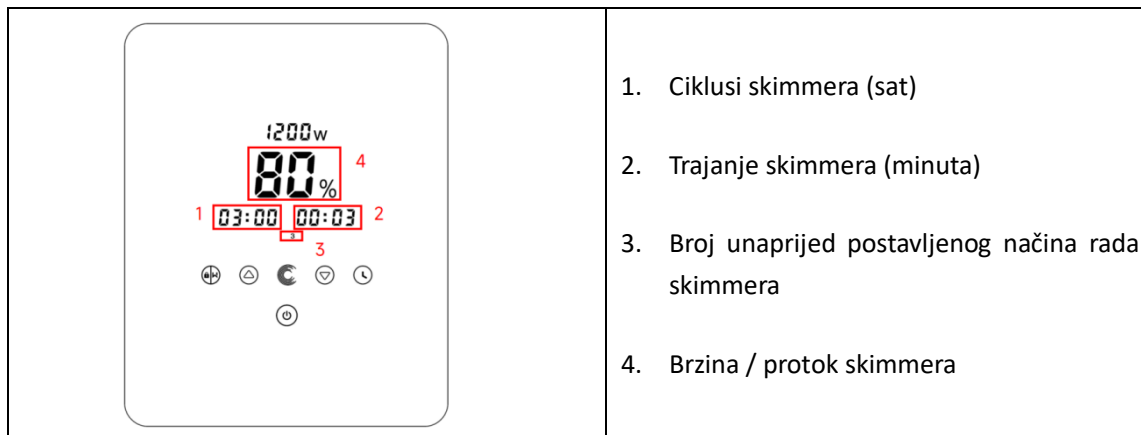

1. Ciklusi skimmera (sat)
2. Trajanje skimmera (minuta)
3. Broj unaprijed postavljenog načina rada skimmera
4. Brzina / protok skimmera

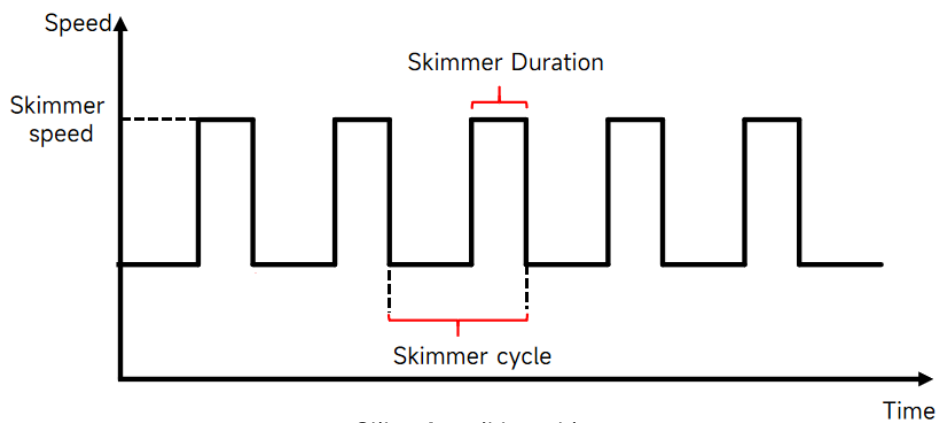

Slika 4 - ciklus skimmera

5.10 Ograničenje brzine / protoka

Korisnici mogu postaviti ograničenje brzine /protoka pumpe kako bi zadovoljili zahtjeve protoka druge opreme poput pješčanih filtera.



Ograničenje brzine / protoka pumpe može se postaviti u postavkama parametara. (vidi 5.11)







100% znači da nema ograničenja brzine, a radni kapacitet se može postaviti od 30% do 120% u normalnom radu.

Model	Ograničenje brzine / protoka	
	Maksimalna brzina trčanja	Maksimalni protok
DCP12-IG	60%-100%	15-25 m ³ /h



Kako bi se osigurale performanse, proces samousisavanja pri svakom pokretanju neće biti ograničen funkcijom ograničenja brzine /protoka .

5.11 Postavljanje parametara





Vrati tvorničke postavke	Isključite pumpu, a zatim držite oba   3 sekunde
--------------------------	--

Provjerite verziju softvera	Isključite pumpu, a zatim držite oba   3 sekunde
Unesite postavku parametra kao što je prikazano u nastavku	Isključite pumpu, a zatim držite oba   na 3 sekunde; Tisak  za odabir adrese parametra i pritisnite  ili  za podešavanje postavke parametra.

Parametar Adresa	Opis	Zadana postavka	Raspon podešavanja
1	Di2 (Digitalni ulaz 2)	Brzina: 100%	Brzina: 30-120%, u koracima od 5% ; Protok: 1 m ³ /h prirasti; DCP12-IG: 8-25 m ³ /h Napomena : Pritisnite  do prebaci se na tok stopa postavka
2	Di3 (Digitalni ulaz 3)	Brzina: 80%	
3	Di4 (Digitalni ulaz 4)	Brzina: 40 %	
4	Talasanje	Brzina: 100%	Brzina: 60-100% , u koracima od 5%; Protok: 1 m ³ /h prirasti; DCP12-IG: 8-25 m ³ /h Napomena : Pritisnite  do prebaci se na tok stopa postavka.
5	Način upravljanja analognim ulazom	0	0: Regulacija struje 1: Regulacija napona
6	Omogućite ili onemogućite samousisavanje pri svakom pokretanju	25	25: omogućuje 0: onemogućuje
7	Rezervirano	0	Nije moguće uređivati
8	Sistemske vrijeme	00:00	00:00 - 23:59

9	Presetiranje 1 načina rada skimera	Skimmer ciklus : 01:00 Skimmera : 00:03 Brzina Skimera : 100%	*Skimmer ciklus: 1 - 24 sata, 1 sat za svaki korak ; * Trajanje Skimmera: 1 - 30 min, 1 min za svaki korak ; *Brzina Skimera : 30%-100%, u koracima od 5%; * Protok Skimera: za 1 m ³ /h prirasti; DCP12-IG: 8-25 m ³ /h Napomena : Pritisnite  do prebaci se na tok stopa postavka.
10	Vremensko razdoblje unaprijed postavljene postavke 1 načina rada skimera	7:00 - 21:00	Vrijeme početka: 00:00 - 24:00 Vrijeme završetka: 00:00-24:00
11	Ograničenje brzine	Brzina: 100%	Brzina: 6 0%-100%, u koracima od 5%; (100% znači da nema ograničenja brzine) Protok : 1 m ³ /h prirasti; DCP12-IG: 15-25 m ³ /h Napomena : Pritisnite  do prebaci se na tok stopa postavka
12	RS485	170(0xAA)	160-190 (0xA0-0xBF), svaki korak po 1.
13	Rezervirano	0	Nije moguće uređivati

Na primjer: Kako omogućiti / Onemogućiti funkciju samousisavanja?

- 1) Unesite postavku parametra: Isključite pumpu, a zatim držite oba   3 sekunde;
- 2) Odaberite adresu parametra: Pritisnite  za odabir adrese 6 ;
- 3) Omogućite ili onemogućite funkciju samousisavanja : Podesite pritiskom na  ili , 25 = Omogućuje, 0 = Onemogućuje .

6.WIFI RAD (IZBORNA STAVKA)

- 1 Preuzmite aplikaciju iGarden
- 2 Registracija računa



Android



iOS

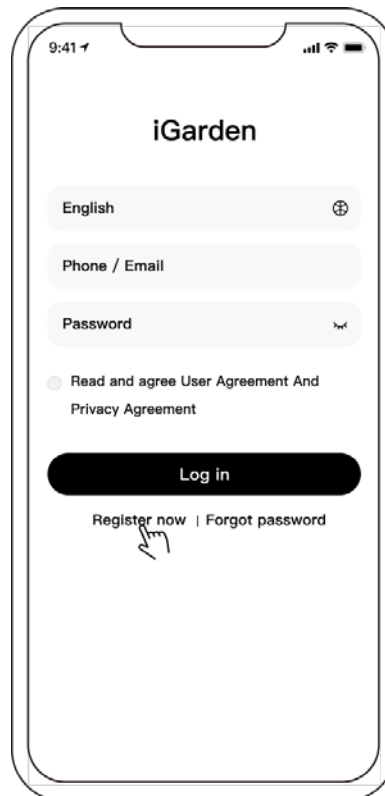

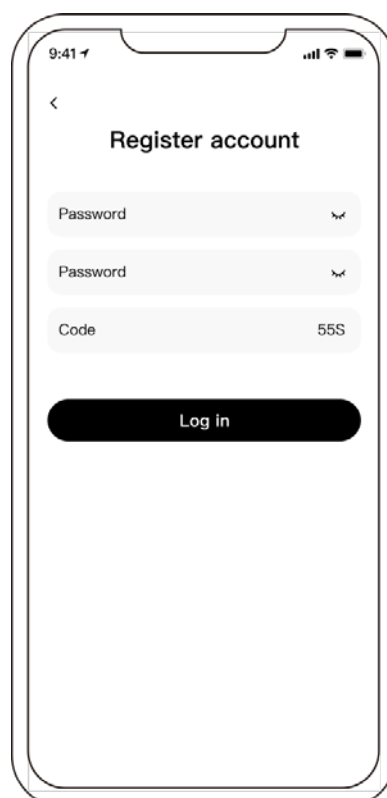

Registracija telefonom / e-poštom



3 Uparivanje aplikacija

Molimo Vas da se uvjerite da je pumpa uključena prije nego što počnete.

(Stanje mreže: 2,4 GHz; 2,4 GHz i 5 GHz kombiniraju se u jedan SSID; ali nema zasebne mreže od 5 GHz)

- 1) Molimo vas da potvrdite da je vaš telefon spojen na Wifi i da je Bluetooth na vašem telefonu UKLJUČEN.
- 2) Pritisnite  3 sekunde za otključavanje zaslona. Nakon uključivanja pumpe, pritisnite  5 sekundi dok ne čujete "Beep", a zatim otpustite.  Treptat će.
- 3) Kliknite "Dodaj uređaj" i zatim slijedite upute za uparivanje uređaja.

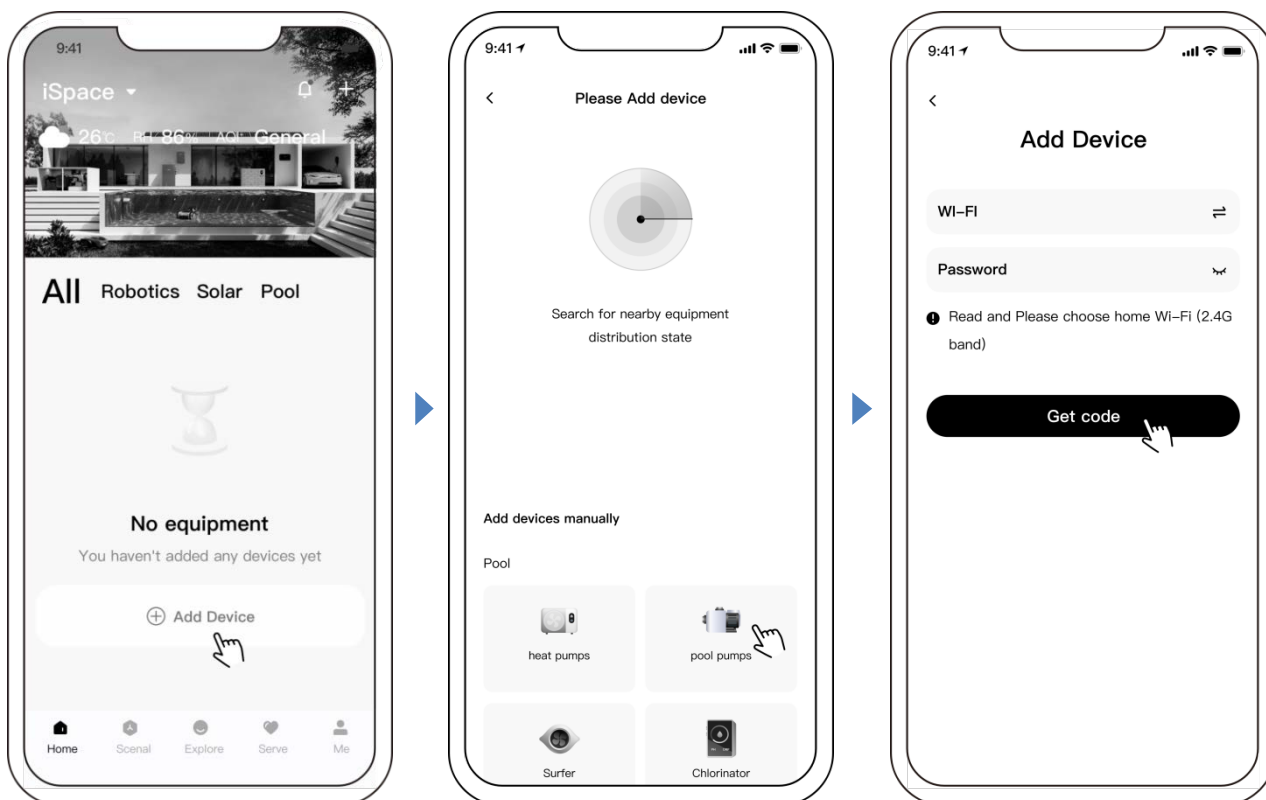

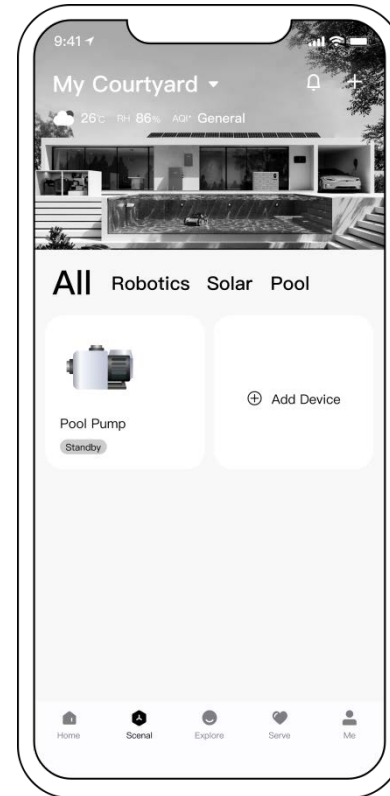
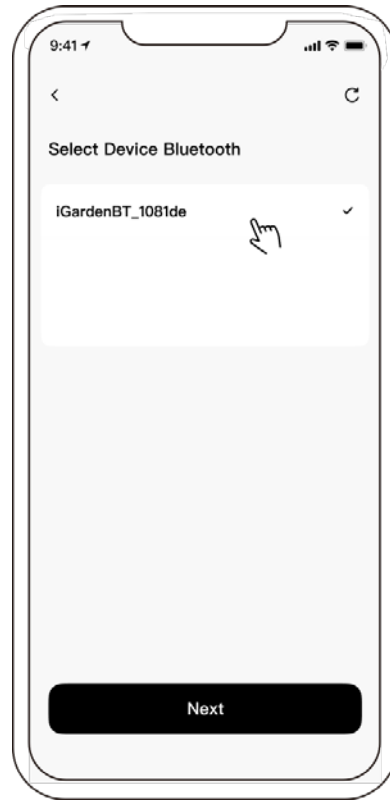
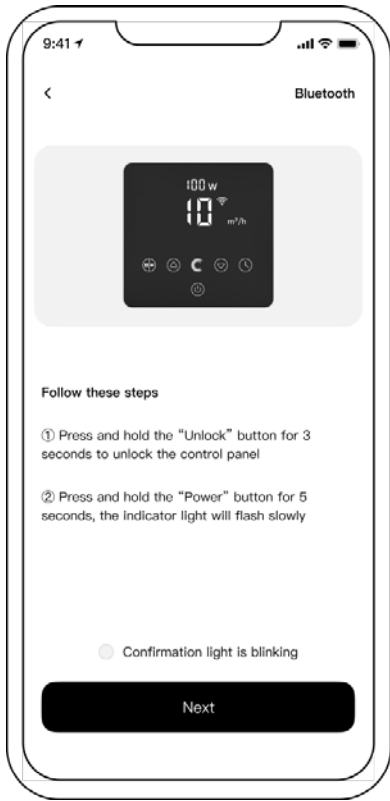

4 Operacija

- 1) Način rada s automatskim pretvaračem (AI način rada) : Promjena jedinica protoka /
Popis kodova pogreške

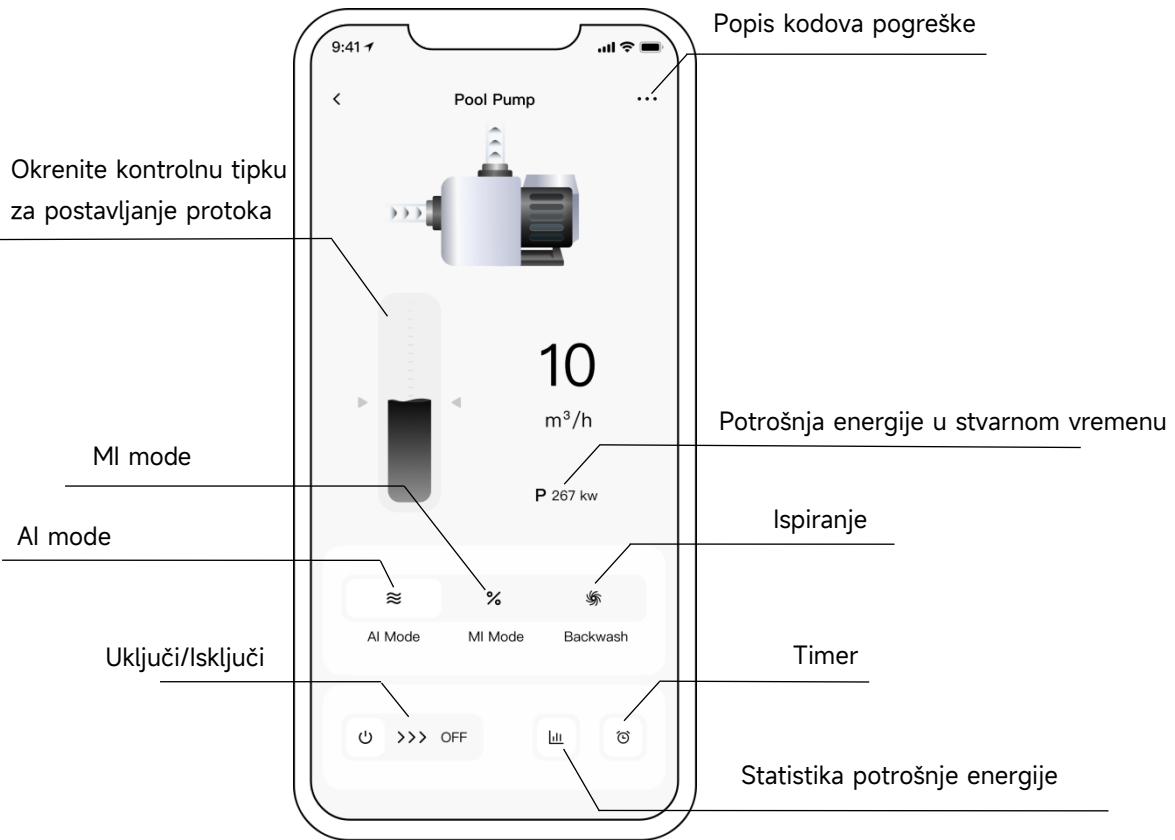

- 2) Ručni inverterski način rada (MI način rada):

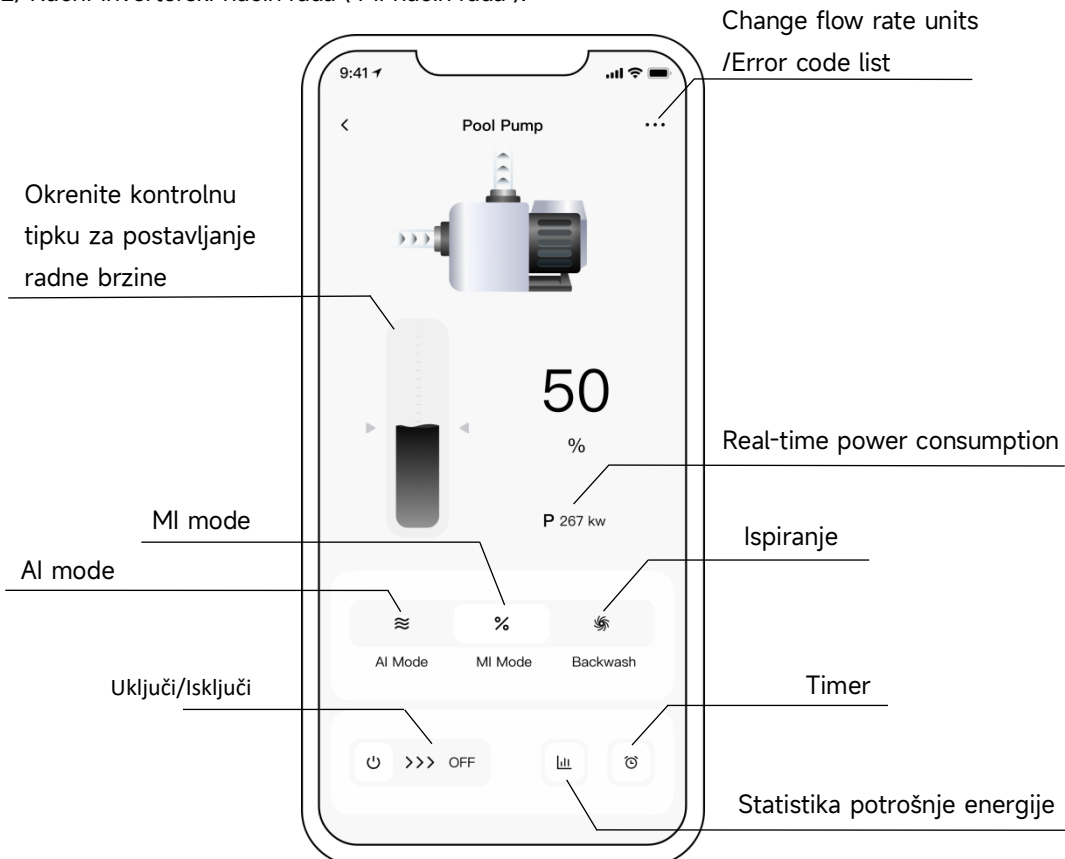

3) Način povratnog ispiranja:

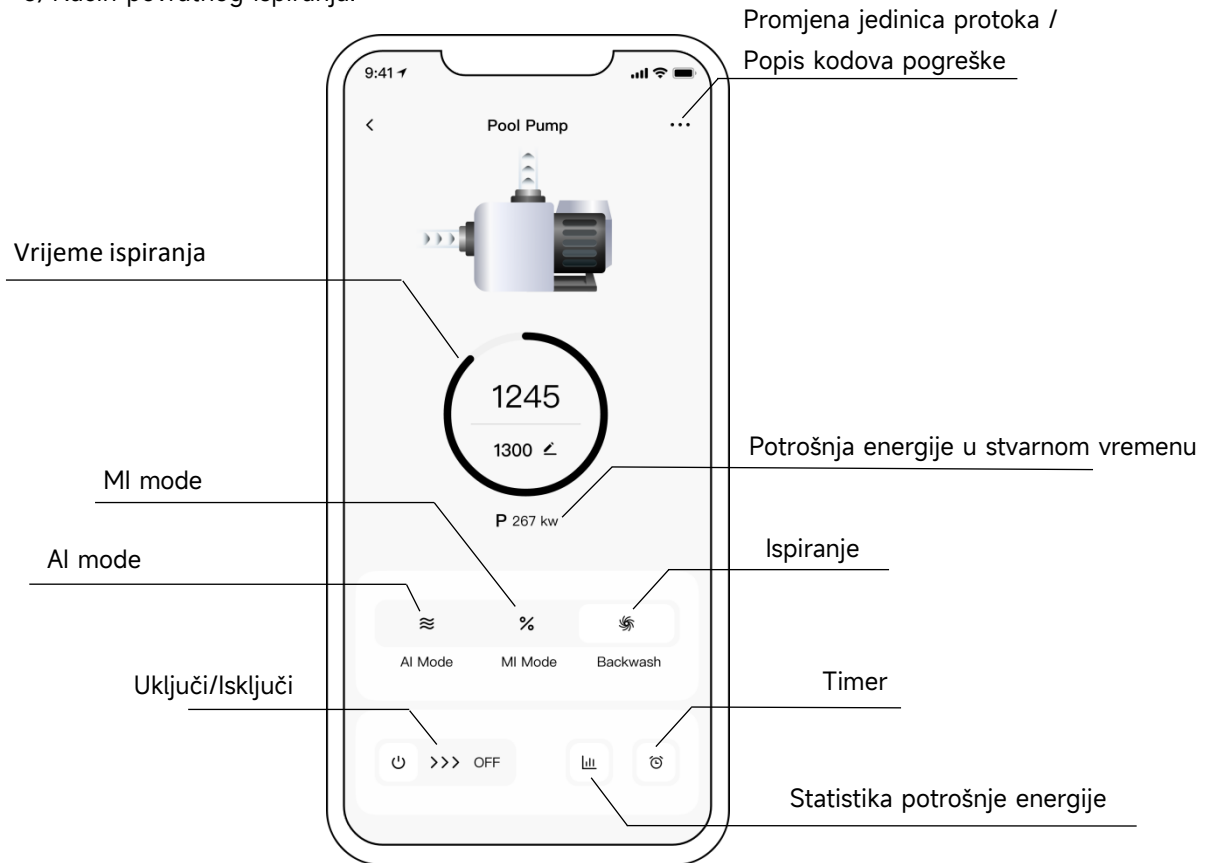

Obavijest za podešavanje timera putem aplikacije:

- 1 Vremenska varijacija je ± 30 s;
- 2 Kako bi se izbjeglo preklapanje vremenskih točaka, što može dovesti do sukoba i poništavanja zbog kašnjenja mreže, preporučuje se da se vrijeme završetka i vrijeme početka sljedećeg vremenskog razdoblja ne preklapaju te da se osigura dovoljan vremenski interval, na primjer, najmanje 2 minute;

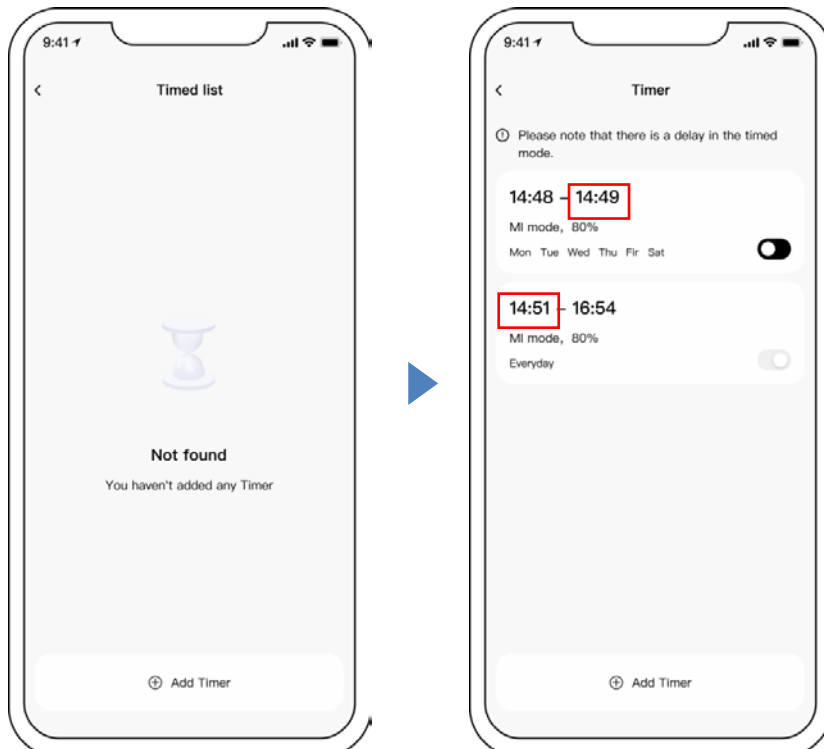

5 Dijeljenje uređaja s članovima obitelji

Korisnici mogu dijeliti uređaje kojima će upravljati članovi njihove obitelji. Molimo vas da prvo omogućite članovima vaše obitelji da registriraju "iGarden", a zatim administrator može postupati na sljedeći način:

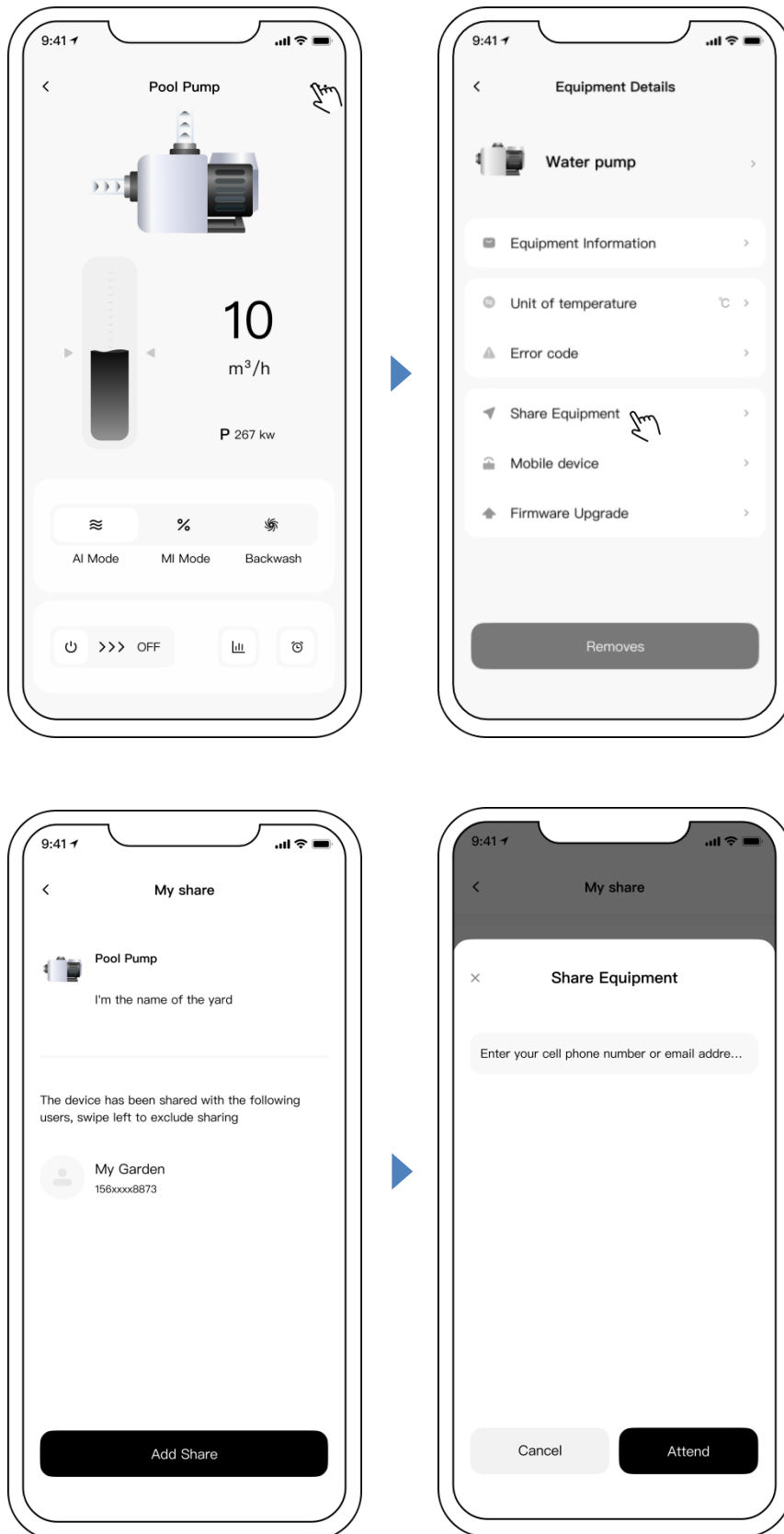

6 Upravljanje vrtom

Na popisu uređaja prikazuje se trenutno dvorište. Nakon klika, korisnici mogu pregledati/prebaciti se na sva trenutna dvorišta, kliknuti na Upravljanje vrtom i također ući na stranicu s popisom dvorišta. Kao što je prikazano u nastavku:

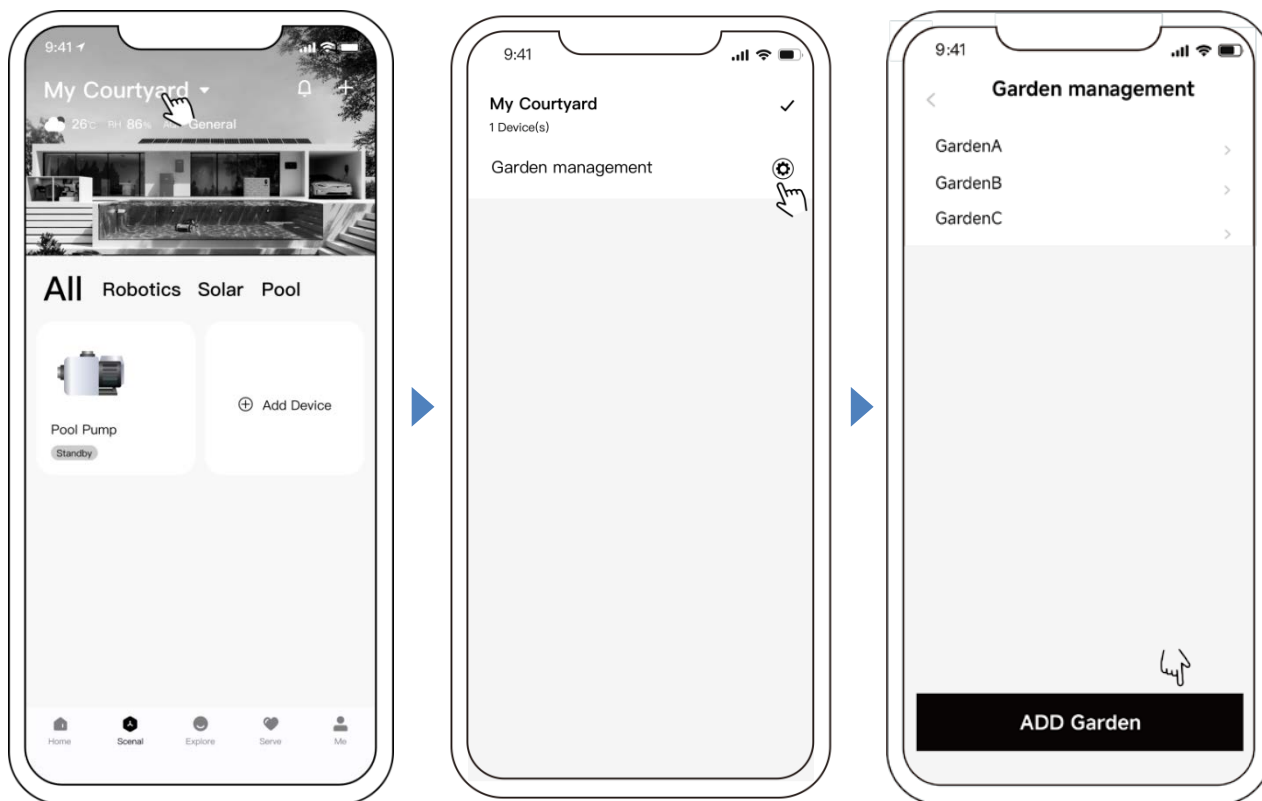

7 Centar za poruke

A: Prikaz poruke: Na stranici s popisom uređaja kliknite ikonu poruke za ulazak u centar za poruke i prikaz odgovarajuće poruke, kao što je prikazano u nastavku: (Uključujući: Alarm, Vrt, Obavijesti)

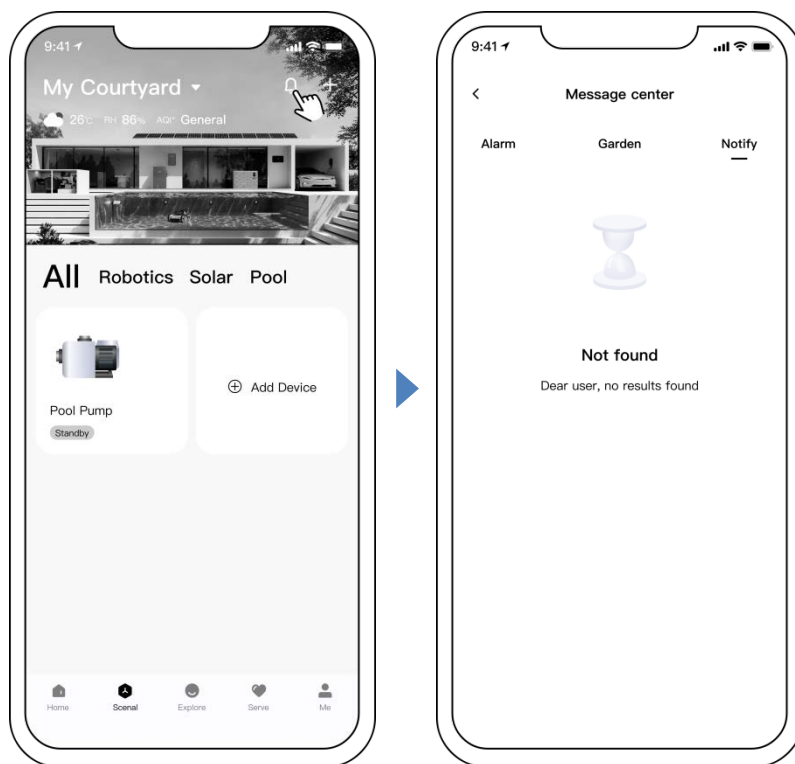

B: Postavke push poruka: Na stranici Postavke kliknite [Postavke push poruka] za ulazak na stranicu Postavke push poruka. Korisnici mogu postaviti postavke push poruka prema klasifikaciji poruke, kao što je prikazano u nastavku:

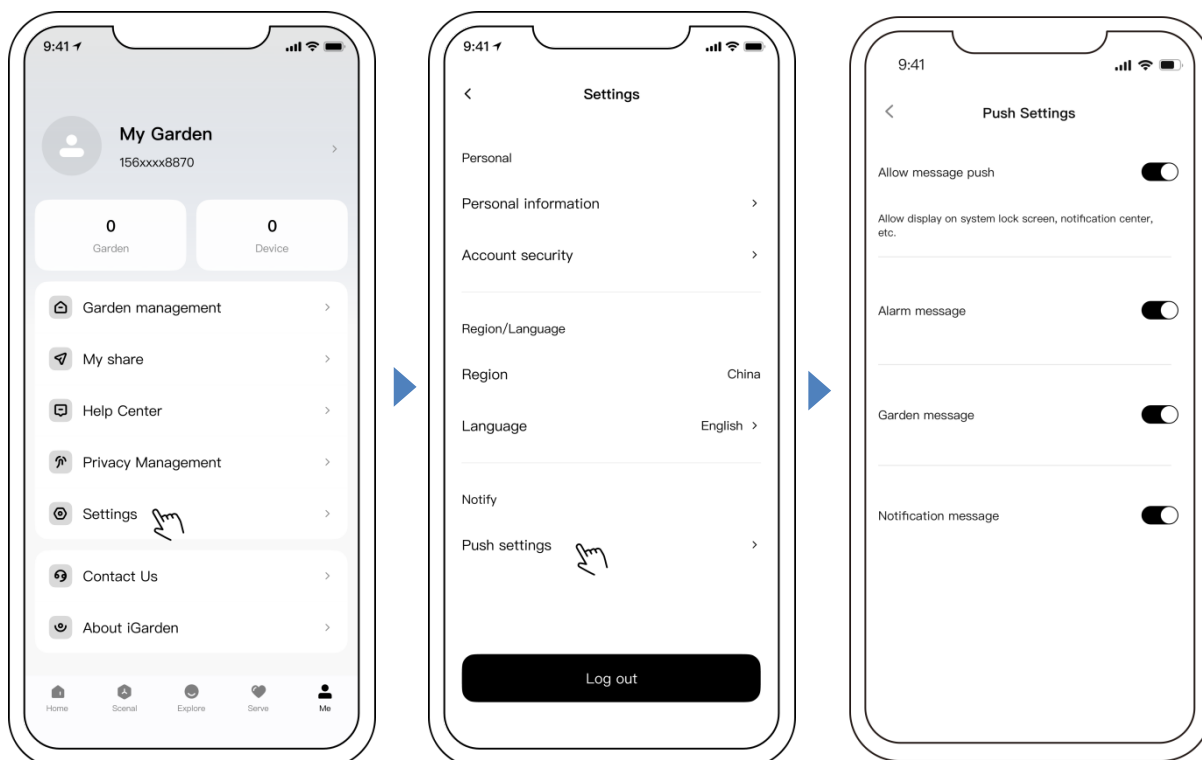

8 Povratne informacije

Ako imate bilo kakvih problema tijekom korištenja, slobodno nam pošaljite povratne informacije. Postupak je sljedeći:

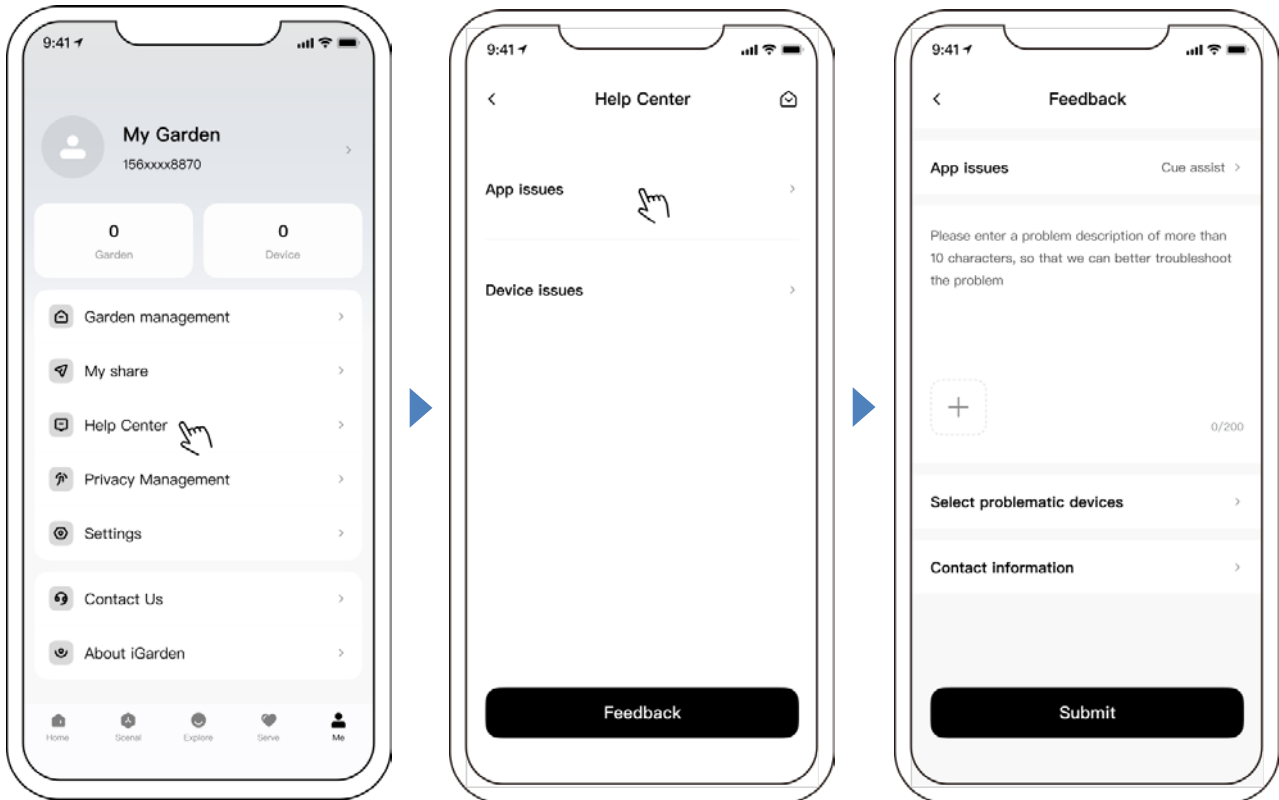

Obavijest:

- 1) Vremenska prognoza je samo za referencu;
- 2) Podaci o potrošnji energije služe samo kao referenca, jer na njih mogu utjecati problemi s mrežom i nepreciznost izračuna;
- 3) Aplikacija je podložna ažuriranjima bez prethodne najave.

7.VANJSKA KONTROLA

Vanjsko upravljanje može se omogućiti putem sljedećih kontakata. Ako je omogućeno više od jednog vanjskog upravljanja, prioritet je sljedeći: Digitalni ulaz > RS485 > Upravljanje putem ploče

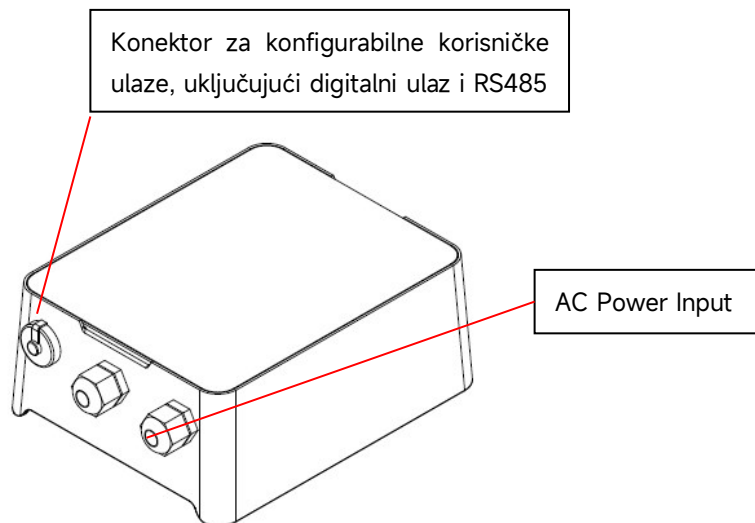

Slika 5 - Položaj priključka

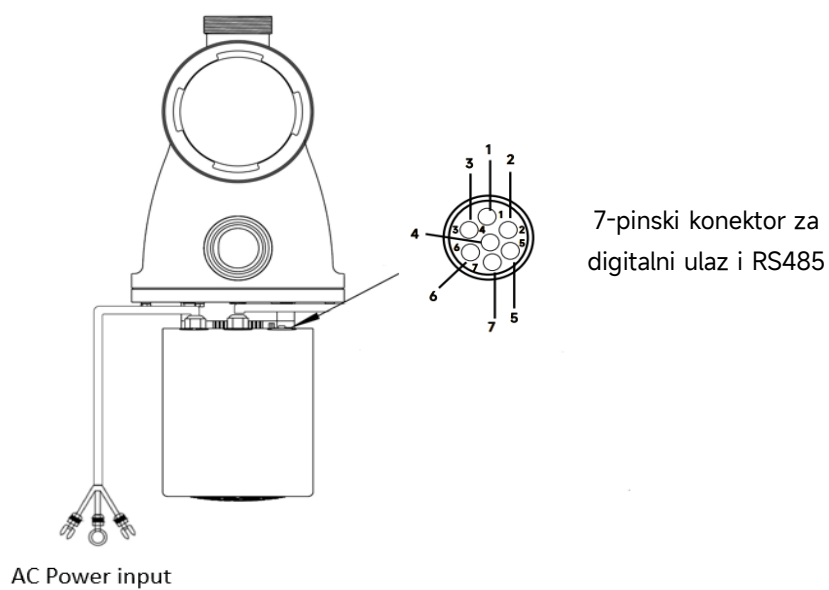

Slika 6 - Konektor za digitalni ulaz i RS485

AC ulaz za napajanje (pogodno za 115 V i 230 V)

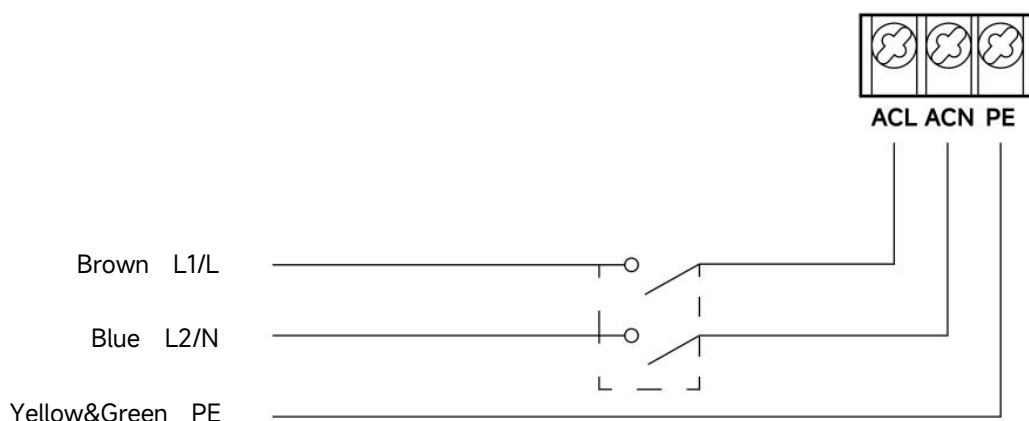

Slika 7 - Priključak za napajni kabel

Vanjska kontrola	Boja	Opis	Bilješka
Digitalni ulaz	Crvena	Di4 (digitalni ulaz 4)	Zadana brzina = 40%
	Crna	Di3 (digitalni ulaz 3)	Zadana brzina = 80%
	Bijela	Di2 (digitalni ulaz 2)	Zadana brzina = 100%
	Siva	Di1 (Digitalni ulaz 1)	Stop
	Žuta boja	Digitalna zemlja (COM)	COM
RS485	Zelena	RS485-A	/
	Smeđa	RS485-B	/

a. Digitalni ulaz

Radni kapacitet određen je stanjem digitalnog ulaza,

- 1) Kada se Di1 (sivi) spoji s COM (žutim), pumpa će se morati zaustaviti; ako se odspoji, digitalna kontrola ne će biti valjana;
- 2) Kada se Di2 (bijeli) spoji s COM (žutim), pumpa će morati raditi na 100%; ako se odspoji, prioritet upravljanja će se vratiti na upravljanje s ploče;
- 3) Kada se Di3 (crni) spoji s COM (žutim), pumpa će obvezno raditi na 80%; ako se odspoji, prioritet upravljanja vratit će se na upravljanje s ploče;
- 4) Kada se Di4 (crveni) spoji s COM (žutim), pumpa će obvezno raditi na 40%; ako se isključi, prioritet upravljanja vratit će se na upravljanje s ploče;
- 5) Kapacitet ulaza (Di2/Di3/Di4) može se mijenjati prema postavkama parametara.

b. RS485

Za povezivanje s RS485-A (zelena) i RS485-B (smeđa), pumpa se može upravljati putem komunikacijskog protokola Modbus 485.

8.ZAŠTITA I KVAR

5.3 na visoku temperaturu i smanjenje brzine - AL01

U "Auto" Inverter/Ručno "Inverterski način rada" i "Način rada s timerom" (osim ispiranja/samousisavanja), kada temperatura modula dosegne prag upozorenja za visoku temperaturu (81 °C), ulazi u stanje upozorenja za visoku temperaturu ; kada temperatura padne na prag aktiviranja upozorenja za visoku temperaturu (78 °C), deaktivira se stanje upozorenja za visoku temperaturu . Područje zaslona naizmjenično prikazuje AL01 i brzinu rada ili protok .

se prikaže AL01 , radni kapacitet će se automatski smanjiti kako slijedi:

- 1) Ako je trenutni radni kapacitet veći od 100 %, radni kapacitet će se automatski smanjiti na 85% ;
- 2) Ako je trenutni radni kapacitet između 85% i 100%, radni kapacitet će se automatski smanjiti za 15%;
- 3) Ako je trenutni radni kapacitet između 70% i 85%, radni kapacitet će se automatski smanjiti za 10%;
- 4) Ako je trenutni radni kapacitet manji od 70%, radni kapacitet će se automatski smanjiti za 5%.

5.4 Zaštita od podnapona - AL02

Uređaj je kompatibilan s naponom od 230 V i 115 V AC .

① Ulaz izmjenične struje: 230 V

Kada uređaj otkrije da je ulazni napon manji od 198 V, ograničit će trenutnu brzinu rada. Područje zaslona naizmjenično prikazuje AL02 i brzinu rada ili protok.

- 1) Kada je ulazni napon manji ili jednak 180 V, radni kapacitet bit će ograničen na 70%;
- 2) Kada je raspon ulaznog napona unutar 180V - 190V, radni kapacitet bit će ograničen na 75%;
- 3) Kada je raspon ulaznog napona unutar 190V - 198V, radni kapacitet bit će ograničen na 85% .

② Ulaz izmjenične struje: 115 V

Kada uređaj otkrije da je ulazni napon manji od 98 V, ograničit će trenutnu brzinu rada. Područje zaslona naizmjenično prikazuje AL02 i brzinu rada ili protok.

- 7) Kada je raspon ulaznog napona unutar 85V - 90V, radni kapacitet bit će ograničen na 75%;
- 8) Kada je ulazni napon u rasponu od 90 V - 98 V, radni kapacitet bit će ograničen na 85% .

Napomena: Ako je ulazni napon manji od 85 V, prikazat će se kod greške E001 (Nenormalan ulazni napon, vidi 8.4).

5.5 Rješavanje problema

Problem	Mogući uzroci i rješenje
Pumpa se ne pokreće	<ul style="list-style-type: none"> • Kvar napajanja, isključeno ili neispravno ožičenje. • Osigurači pregorjeli ili je otvoren toplinski preopterećenje. • Provjerite rotaciju osovine motora radi slobodnog kretanja i odsustva prepreka. • Zbog dugog mirovanja. Isključite napajanje i ručno okrenite stražnju osovinu motora nekoliko puta odvijačem.
Pumpa se ne puni	<ul style="list-style-type: none"> • Ispraznite kućište pumpe/filtera. Provjerite je li kućište pumpe/filtera napunjeno vodom i je li O-prsten poklopca čist. • Labavi spojevi na usisnoj strani. • Cjedilo ili košara skimera puna otpada. • Usisna strana je začepljena. • Udaljenost između ulaza pumpe i razine tekućine je veća od 2 m, visinu ugradnje pumpe treba smanjiti.
Nizak protok vode	<ul style="list-style-type: none"> • Pumpa se ne puni. • Zrak ulazi u usisnu cijev. • Košara puna otpada. • Nedovoljna razina vode u bazenu.
Pumpa je bučna	<ul style="list-style-type: none"> • Propuštanje zraka u usisnim cijevima, kavitacija uzrokovana ograničenim ili premalim usisnim vodom ili propuštanjem na bilo kojem spoju, niskom razinom vode u bazenu i neograničenim povratnim vodovima ispusnog sustava. • Vibracije uzrokovane nepravilnom ugradnjom itd. • Oštećen ležaj motora ili impeler (potrebno je kontaktirati dobavljača za popravak).

5.6 Kod pogreške

Kada uređaj otkrije kvar, automatski će se zaustaviti i prikazati kod greške . Nakon zaustavljanja od 15 sekundi, provjerite je li kvar otklonjen . Ako se obriše, pumpa će nastaviti raditi .

Artikal	Kod pogreške	Detalji	
1	E001	Opis	Nenormalan ulazni napon : Napon napajanja je izvan raspona od 165 V do 275 V.
		Proces	Pumpa će se automatski zaustaviti na 15 sekundi i nastaviti raditi ako otkrije da je napon napajanja unutar raspona.
2	E002	Opis	Prekomjerna izlazna struja : Vršna struja pumpe je veća od zaštitne struje.
		Proces	Pumpa će se automatski zaustaviti na 15 sekundi, a zatim nastaviti s radom , ako se to dogodi tri puta zaredom, pumpa će se isključiti i potrebno ju je provjeriti i ručno ponovno pokrenuto .

3	E102	Opis	Hladnjak greška: Temperatura hladnjaka doseže 91 °C tijekom 10 sekundi . Ili senzor hladnjaka detektira otvoreni ili kratki spoj .
		Proces	1. Pumpa će se automatski zaustaviti na 30 sekundi i nastaviti s radom ako detektira da je temperatura hladnjaka niža od 81 °C. 2. Pumpa će se automatski zaustaviti na 15 sekundi i nastaviti s radom ako otkrije da senzor hladnjaka nije otvoren ili da ima kratki spoj .
4	E103	Opis	Greška glavne upravljačke ploče: T Glavna upravljačka ploča je neispravan.
		Proces	Pumpa će se automatski zaustaviti na 15 sekundi, a zatim nastaviti s radom , ako se to dogodi tri puta zaredom, pumpa će se isključiti i potrebno ju je provjeriti i ručno ponovno pokrenuto .
5	E104	Opis	Zaštita od nedostatka faze: Kabeli motora nisu priključeni na glavnu ploču pogona .
		Proces	Pumpa će se automatski zaustaviti na 15 sekundi, a zatim nastaviti s radom , ako se to dogodi tri puta zaredom, pumpa će se isključiti i potrebno ju je provjeriti i ručno ponovno pokrenuto .
6	E203	Opis	Pogreška očitanja RTC vremena : Čitanje i pisanje Podaci na timeru su netočni .
		Proces	On pumpa treba biti isključen i ručno ponovno pokrenut.
7	E204	Opis	Greška u čitanju EEPROM-a na ploči zaslona : Čitanje i pisanje informacije o EEPROM ploče zaslona nije ispravan .
		Proces	On pumpa treba biti isključen i ručno ponovno pokrenut.
8	E205	Opis	Komunikacijska greška : T Kvar komunikacije između ploče zaslona i glavne upravljačke ploče traje 15 sekundi.
		Proces	Pumpa će se automatski zaustaviti na 15 sekundi i nastaviti s radom ako otkrije da komunikacija između ploče zaslona i glavne upravljačke ploče traje 1 sekundu.
9	E207	Opis	Nema zaštite od vode : U pumpi nema vode.
		Proces	isključite pumpu, napunite pumpu vodom i ponovno je pokrenite. Ako se ovo dogodi dva puta uzastopno, pumpa će se isključiti i potrebno ju je ručno provjeriti.
10	E209	Opis	Gubitak punjenja : Pumpa se ne može sama usisavati zbog razloga kao što su prekoračenje raspona usisavanja ili previše kompliciran cjevovod.
		Proces	Provjerite pumpu ili cjevovod da nema curenja, a zatim napunite pumpu vodom i ponovno je pokrenite.

9.ODRŽAVANJE

Često praznite košaru za sito. Košaru treba pregledati kroz prozirni poklopac i isprazniti je kada se unutra vidi hrpa smeća. Treba slijediti sljedeće upute:

- 1). Isključio je napajanje.
- 2). Odvijte poklopac košare cjedila u smjeru suprotnom od kazaljke na satu i uklonite ga.
- 3). Podignite košaru cjedila.
- 4). Ispraznite zaostali otpad iz košare i isperite ostatke ako je potrebno.

Napomena: Ne udarajte plastičnu košaru o tvrdnu površinu jer će to uzrokovati oštećenja.

- 5). Pregledajte košaru ima li znakova oštećenja i zamijenite je.
- 6). Provjerite O-prsten poklopca na istezanje, pukotine, pukotine ili bilo kakva druga oštećenja
- 7). Vratite poklopac, dovoljno je ručno zatezanje.

Napomena: Povremeni pregled i čišćenje košare cjedila pomoći će produžiti njezin vijek trajanja.

10.JAMSTVO I IZUZETKE

Ako se tijekom jamstvenog roka pojavi nedostatak, proizvođač će, po vlastitom izboru, popraviti ili zamijeniti takav predmet ili dio o vlastitom trošku. Kupci moraju slijediti postupak reklamacije kako bi ostvarili pravo na jamstvo.

Jamstvo će biti nevažeće u slučajevima nepravilne ugradnje, nepravilnog rada, neprimjerene upotrebe, neovlaštenog rukovanja ili korištenja neoriginalnih rezervnih dijelova.

11.ODLAGANJE



Prilikom odlaganja proizvoda, molimo vas da otpadne proizvode sortirate kao električni ili elektronički otpad ili ih predate lokalnom sustavu za prikupljanje otpada.

Odvojeno prikupljanje i recikliranje otpadne opreme prilikom odlaganja pomoći će



osigurati da se ona reciklira na način koji štiti ljudsko zdravlje i okoliš. Za informacije o tome

gdje možete odložiti svoju vodenu pumpu za recikliranje obratite se lokalnim vlastima.

